



MODEL:

AFL3-W15C/W19C-ULT3

Flat Bezel Panel PC with Intel® Core™ i5-6300U / Celeron® 3955U
CPU, Touchscreen, Four USB 3.0, Dual GbE LAN, RS-232/422/485,
HD Audio, Wi-Fi 802.11a/b/g/n/ac and RoHS

User Manual

Revision

Date	Version	Changes
November 1, 2016	1.00	Initial release



Safety Instructions

- en** Warning! Read the user manual before connecting the system to the power source.
- de** Vorsicht! Bitte lesen Sie die Bedienungsanleitung, bevor Sie das System an eine Stromquelle anschließen.
- fr** Attention! Avant de brancher le système à la source d'alimentation, consultez le mode d'emploi.
- it** Avvertenza! Consultare il manuale utente prima di collegare il sistema all'alimentatore.
- es** Atención! Lea atentamente este manual del usuario antes de operar la fuente de alimentación.
- zh** 警告！在將系統連接到電源之前，請仔細閱讀使用手冊。
- cn** 警告！在將系統連接到電源之前，請仔細閱讀使用手冊。
-

- en** Warning! To prevent the system from overheating, do not operate it in an area that exceeds the maximum operating temperature described in the user manual.
- de** Vorsicht! Um eine Überhitzung des Systems zu vermeiden, betreiben Sie es ausschließlich im zulässigen Betriebstemperaturbereich. Dieser ist in der Bedienungsanleitung vermerkt.
- fr** Attention! Pour éviter la surchauffe du système, ne l'utilisez pas dans une zone dont la température dépasse les limites décrits dans le mode d'emploi.
- it** Avvertenza! Per evitare che il sistema si surriscaldi, non utilizzarlo in aree che superino la temperatura massima d'esercizio descritta nel manuale utente.
- es** Atención! Para evitar el excesivo calentamiento del sistema, no opere en las condiciones de temperatura superior a lo recomendado en este manual del usuario.
- zh** 警告！為防止系統過熱，不要在超過使用手冊上記載的產品工作溫度範圍之外操作此系統。
- cn** 警告！為防止系統過熱，不要在超過使用手冊上記載的產品工作溫度範圍之外操作此系統。
-

- en** Warning! Use only the adapter and power cord approved for this system. Use of another type of adapter may risk fire or explosion. Please refer to the user manual for the power adapter specifications.
- de** Vorsicht! Nur zugelassene Netzteile und Netzkabel dürfen verwendet werden. Die Benutzung von anderen Netzteilen kann einen Brand oder eine Explosion zur Folge haben. Prüfen Sie die jeweiligen Spezifikationen in der Bedienungsanleitung.
- fr** Attention! Utilisez exclusivement le câble d'alimentation et l'adaptateur homologués pour ce système. L'utilisation d'un autre type d'adaptateur risquerait de provoquer un incendie ou une explosion. Veuillez référer au mode d'emploi pour les spécifications de l'adaptateur d'alimentation.
- it** Avvertenza! Utilizzare solo l'adattatore e il cavo di alimentazione approvati per questo sistema. L'uso di un altro tipo di adattatore può causare rischio d'incendio o esplosione. Si prega di fare riferimento al manuale utente per le specifiche sull'alimentazione.
- es** Atención! Utilice solamente el adaptador de corriente alterna (CA) con Marcas Conformidad otorgadas. Cualquier otro adaptador no otorgado aumenta el riesgo de explosión o incendio. Por favor consulte el manual del usuario para las especificaciones del adaptador de alimentación.
- zh** 警告！只能使用經過認證、適用於本系統的電源變壓器與電源線。使用不適用的電源變壓器將可能導致火災或爆炸。電源變壓器規格請參考使用手冊。
- cn** 警告！只能使用经过认证，适用于本系统的电源适配器与电源线。使用不适用的电源适配器将可能导致火灾或爆炸。电源适配器规格请参考使用手冊。

-
- en** Warning! Ultimate disposal of this product should be handled according to all national laws and regulations.
- de** Vorsicht! Die Entsorgung dieses Produkts sollte gemäß allen Bestimmungen und Gesetzen des Landes erfolgen.
- fr** Attention! La mise au rebut ou le recyclage de ce produit sont généralement soumis aux lois et/ou directives de respect de l'environnement. Renseignez-vous auprès de l'organisme compétent.
- it** Avvertenza! Lo smaltimento di questo prodotto deve essere eseguito secondo le leggi e i regolamenti locali.
- es** Atención! La disposición final de residuos de este producto se debe cumplir con las normativas y leyes del país.
- zh** 警告！本產品的廢棄處理應根據該國家的法律和規章進行。
- cn** 警告！本产品的废弃处理应根据该国家的法律和规章进行。
-

Copyright

COPYRIGHT NOTICE

The information in this document is subject to change without prior notice in order to improve reliability, design and function and does not represent a commitment on the part of the manufacturer.

In no event will the manufacturer be liable for direct, indirect, special, incidental, or consequential damages arising out of the use or inability to use the product or documentation, even if advised of the possibility of such damages.

This document contains proprietary information protected by copyright. All rights are reserved. No part of this manual may be reproduced by any mechanical, electronic, or other means in any form without prior written permission of the manufacturer.

TRADEMARKS

All registered trademarks and product names mentioned herein are used for identification purposes only and may be trademarks and/or registered trademarks of their respective owners.

Manual Conventions



WARNING

Warnings appear where overlooked details may cause damage to the equipment or result in personal injury. Warnings should be taken seriously.



CAUTION

Cautionary messages should be heeded to help reduce the chance of losing data or damaging the product.



NOTE

These messages inform the reader of essential but non-critical information. These messages should be read carefully as any directions or instructions contained therein can help avoid making mistakes.



HOT SURFACE

This symbol indicates a hot surface that should not be touched without taking care.

Table of Contents

1 INTRODUCTION.....	1
1.1 OVERVIEW.....	2
1.2 MODEL VARIATIONS	3
1.3 FEATURES.....	3
1.4 FRONT PANEL.....	4
1.5 BOTTOM PANEL.....	5
1.6 REAR PANEL.....	6
1.7 SYSTEM SPECIFICATIONS.....	7
1.8 DIMENSIONS.....	10
1.8.1 AFL3-W15C-ULT3 Dimensions.....	10
1.8.2 AFL3-W19C-ULT3 Dimensions.....	11
2 UNPACKING	12
2.1 UNPACKING.....	13
2.2 PACKING LIST.....	13
2.3 OPTIONAL ITEMS.....	15
3 INSTALLATION	17
3.1 ANTI-STATIC PRECAUTIONS	18
3.2 INSTALLATION PRECAUTIONS	18
3.3 INSTALLATION AND CONFIGURATION STEPS	19
3.4 REMOVING THE BACK COVERS	19
3.5 M.2 MODULE INSTALLATION.....	22
3.6 mSATA MODULE INSTALLATION (FULL-SIZE).....	24
3.7 HDD INSTALLATION.....	27
3.8 DB-9 SERIAL PORT PIN 9 SELECTION.....	29
3.9 RS-232/422/485 SERIAL PORT SELECTION	30
3.9.1 COM1 Pinouts	31
3.10 CLEAR CMOS.....	31
3.11 AT/ATX MODE SELECTION	32
3.11.1 AT Power Mode.....	32

3.11.2 ATX Power Mode	32
3.12 MOUNTING THE SYSTEM	33
3.12.1 Wall Mounting.....	33
3.12.2 Panel Mounting.....	36
3.12.3 Cabinet and Rack Installation	40
3.12.4 Arm Mounting	43
3.12.5 Stand Mounting	45
3.13 POWERING ON THE SYSTEM.....	46
3.14 RESET THE SYSTEM	47
3.15 SOFTWARE INSTALLATION	47
3.16 INSTALLING WINDOWS 7 FROM USB 3.0 DRIVES	48
4 BIOS SETUP	49
4.1 INTRODUCTION.....	50
4.1.1 Starting Setup.....	50
4.1.2 Using Setup	50
4.1.3 Getting Help.....	51
4.1.4 Unable to Reboot after Configuration Changes	51
4.1.5 BIOS Menu Bar.....	51
4.2 MAIN.....	52
4.3 ADVANCED.....	53
4.3.1 ACPI Settings	54
4.3.2 F81866 Super IO Configuration	55
4.3.2.1 Serial Port n Configuration	55
4.3.2.1.1 Serial Port 1 Configuration	56
4.3.2.1.2 Serial Port 2 Configuration	57
4.3.2.1.3 Serial Port 3 Configuration	58
4.3.2.1.4 Serial Port 4 Configuration	59
4.3.3 F81866 H/W Monitor.....	60
4.3.4 RTC Wake Settings	61
4.3.5 Serial Port Console Redirection	62
4.3.5.1 Legacy Console Redirection Settings	63
4.3.5.2 Console Redirection Settings.....	64
4.3.6 CPU Configuration.....	66
4.3.7 SATA Configuration	68

AFL3-W15C/W19C-ULT3 Panel PC

4.3.8 USB Configuration.....	70
4.3.9 IEI Feature.....	71
4.4 CHIPSET	72
4.4.1 System Agent (SA) Configuration	72
4.4.1.1 Graphics Configuration.....	73
4.4.1.1.1 LCD Control	75
4.4.1.2 Memory Configuration	76
4.4.2 PCH-IO Configuration	76
4.4.2.1 PCI Express Configuration	77
4.4.2.2 HD Audio Configuration.....	78
4.5 SECURITY.....	79
4.6 BOOT.....	80
4.7 EXIT	82
5 SYSTEM MAINTENANCE	84
5.1 SYSTEM MAINTENANCE INTRODUCTION	85
5.2 ANTI-STATIC PRECAUTIONS	85
5.3 TURN OFF THE POWER	86
5.4 SO-DIMM MODULE REPLACEMENT.....	86
6 INTERFACE CONNECTORS	89
6.1 PERIPHERAL INTERFACE CONNECTORS.....	90
6.2 INTERNAL PERIPHERAL CONNECTORS	91
6.2.1 Audio Connector (AUDIO_OUT1).....	92
6.2.2 Audio Out Connector (AUDIO_OUT2).....	92
6.2.3 Battery Connector (BAT1).....	93
6.2.4 Debug Connector (DBG_PORT1).....	93
6.2.5 Digital I/O Connector (DIO1).....	93
6.2.6 DisplayPort Connector (DP1).....	94
6.2.7 Inverter Connector (INVERTER1).....	94
6.2.8 LVDS Connector (LVDS1).....	94
6.2.9 M.2 M-key Slot (M2_M_KEY)	95
6.2.10 MCU Connector (HOTKEY_CN1)	96
6.2.11 Microphone Connector (DMIC1).....	97
6.2.12 PCIe Mini Connector, Full-Size/Half-size (M_PCIE1)	97

6.2.13 Power Button Connector (PW_BTN1).....	98
6.2.14 Power LED Connector (PW_LED1).....	98
6.2.15 RS-232 Serial Port Connector (COM3).....	98
6.2.16 RS-232 Serial Port Connector (COM4).....	99
6.2.17 SATA Connector (SATA1).....	99
6.2.18 SPI Flash Connector (JSP11).....	99
6.2.19 Touch Panel Connector (TS1).....	100
6.2.20 TTL Serial Connector, COM6 (NFC_COM6).....	100
6.2.21 USB Connector (BAR_USB1).....	100
6.2.22 USB Connector (BT_USB1).....	101
6.2.23 USB Connector (CAM_USB1).....	101
6.2.24 USB Connector (RFID_USB1).....	101
6.2.25 USB Connector (TOUCH_USB1).....	102
6.2.26 USB 2.0 Connector (USB20_CN1).....	102
6.2.27 USB Power Connector (USB_PWR1).....	102
6.3 EXTERNAL INTERFACE PANEL CONNECTORS	103
6.3.1 Ethernet Connectors (LAN2 & LAN3).....	103
6.3.2 HDMI Connector (HDMI1).....	104
6.3.3 Power Connector (PWR1).....	104
6.3.4 RS-232/422/485 DB-9 Serial Port (COM1).....	104
6.3.5 RS-232 RJ-45 Serial Port (COM2).....	105
6.3.6 USB 3.0 Connectors (USB_CON1).....	105
6.3.7 USB 3.0 Connectors (USB_CON2).....	106
6.4 PRECONFIGURED JUMPER SETTINGS.....	106
6.4.1 LVDS Panel Voltage Selection Jumper (J_VLVDS1).....	107
6.4.2 LVDS Panel Resolution Selection Jumper (SW1).....	107
A REGULATORY COMPLIANCE	108
B SAFETY PRECAUTIONS	114
B.1 SAFETY PRECAUTIONS.....	115
B.1.1 General Safety Precautions.....	115
B.1.2 Anti-static Precautions	116
B.1.3 Product Disposal.....	117
B.2 MAINTENANCE AND CLEANING PRECAUTIONS	118
B.2.1 Maintenance and Cleaning.....	118

AFL3-W15C/W19C-ULT3 Panel PC

<i>B.2.2 Cleaning Tools</i>	118
C BIOS MENU OPTIONS	120
D WATCHDOG TIMER	123
E HAZARDOUS MATERIALS DISCLOSURE	126

List of Figures

Figure 1-1: AFL3-W15C/W19C-ULT3 Flat Bezel Panel PC	2
Figure 1-2: Front View	4
Figure 1-3: AFL3-W15C-ULT3 Bottom Panel	5
Figure 1-4: AFL3-W19C-ULT3 Bottom Panel	5
Figure 1-5: AFL3-W19C-ULT3 Rear View	6
Figure 1-6: AFL3-W15C-ULT3 Dimensions (mm)	10
Figure 1-7: AFL3-W19C-ULT3 Dimensions (mm)	11
Figure 3-1: AFL3-W15C-ULT3 Back Cover Retention Screws	19
Figure 3-2: AFL3-W19C-ULT3 Back Cover Retention Screws	20
Figure 3-3: AFL3-W15C-ULT3 Aluminum Cover Retention Screws	20
Figure 3-4: AFL3-W19C-ULT3 Aluminum Cover Retention Screws	21
Figure 3-5: Lift the Aluminum Cover	21
Figure 3-6: M.2 Module Slot Location.....	22
Figure 3-7: Inserting the M.2 Module into the Slot at an Angle	23
Figure 3-8: Securing the M.2 Module.....	23
Figure 3-9: mSATA Module Slot Location.....	24
Figure 3-10: Removing the Retention Screw and Standoff.....	25
Figure 3-11: Installing the Standoff	25
Figure 3-12: Installing an mSATA Module	26
Figure 3-13: Securing the mSATA Module.....	26
Figure 3-14: HDD Bracket Retention Screws.....	27
Figure 3-15: HDD Retention Screws	28
Figure 3-16: HDD Installation	28
Figure 3-17: DB-9 Serial Port Pin 9 Setting Jumper Locations.....	29
Figure 3-18: RS-232/422/485 Selection Jumper Locations.....	30
Figure 3-19: Clear CMOS Button Location.....	31
Figure 3-20: AT/ATX Switch Location.....	32
Figure 3-21: Wall-mounting Bracket.....	34
Figure 3-22: Chassis Support Screws.....	35
Figure 3-23: Secure the Panel PC	36
Figure 3-24: AFL3-W15C-ULT3 Cutout Dimensions.....	36

AFL3-W15C/W19C-ULT3 Panel PC

Figure 3-25: AFL3-W19C-ULT3 Cutout Dimensions.....	37
Figure 3-26: Panel Mounting Kit Installation	38
Figure 3-27: Securing Panel Mounting Brackets.....	39
Figure 3-28: Rack Mounting Kit Installation	41
Figure 3-29: Securing Rack Mounting Brackets.....	42
Figure 3-30: Install into a Rack/Cabinet	42
Figure 3-31: Arm Mounting Retention Screw Holes.....	44
Figure 3-32: Arm Mounting	44
Figure 3-33: Stand Mounting (Stand-A/Bxx)	45
Figure 3-34: Powering On the System.....	46
Figure 3-35: Reset Button Location.....	47
Figure 5-1: SO-DIMM module Location	87
Figure 5-2: SO-DIMM Installation	87
Figure 6-1: Main Board Layout Diagram	90

List of Tables

Table 1-1: Model Variations	3
Table 1-2: System Specifications.....	9
Table 3-1: COM1 Pin 9 Setting Jumper Settings (JP5)	29
Table 3-2: COM2 Pin 9 Setting Jumper Settings (JP4)	29
Table 3-3: RS-232422/485 Selection Jumper Settings (COM1_SEL1)	30
Table 3-4: RS-232/422/485 Selection Jumper Settings (JP3)	30
Table 3-5: RS-232/422/485 Serial Port (COM1) Pinouts	31
Table 6-1: Peripheral Interface Connectors	92
Table 6-2: Audio Connector (AUDIO_OUT1) Pinouts.....	92
Table 6-3: Audio Out Connector (AUDIO_OUT2) Pinouts	92
Table 6-4: Battery Connector (BAT1) Pinouts	93
Table 6-5: Debug Connector (DBG_PORT1) Pinouts.....	93
Table 6-6: Digital I/O Connector (DIO1) Pinouts.....	93
Table 6-7: DisplayPort Connector (DP1) Pinouts	94
Table 6-8: Inverter Connector (INVERTER1) Pinouts.....	94
Table 6-9: LVDS Connector (LVDS1) Pinouts.....	95
Table 6-10: M.2 M-key Slot (M2_M_KEY) Pinouts.....	96
Table 6-11: MCU Connector (HOTKEY_CN1) Pinouts.....	97
Table 6-12: Microphone Connector (DMIC1) Pinouts	97
Table 6-13: PCIe Mini Connector (M_PCIE1) Pinouts	98
Table 6-14: Power Button Connector (PW_BTN1) Pinouts	98
Table 6-15: Power LED Connector (PW_LED1) Pinouts.....	98
Table 6-16: RS-232 Serial Port Connector (COM3) Pinouts	98
Table 6-17: RS-232 Serial Port Connector (COM4) Pinouts	99
Table 6-18: SATA Connector (SATA1) Pinouts	99
Table 6-19: SPI Flash Connector (JSPI1) Pinouts	99
Table 6-20: Touch Panel Connector (TS1) Pinouts.....	100
Table 6-21: TTL Serial Connector, COM6 (NFC_COM6) Pinouts	100
Table 6-22: USB Connector (BAR_USB1) Pinouts.....	100
Table 6-23: USB Connector (BT_USB1) Pinouts	101
Table 6-24: USB Connector (CAM_USB1) Pinouts.....	101

AFL3-W15C/W19C-ULT3 Panel PC

Table 6-25: USB Connector (RFID_USB1) Pinouts	101
Table 6-26: USB Connector (TOUCH_USB1) Pinouts	102
Table 6-27: USB 2.0 Connector (USB20_CN1) Pinouts.....	102
Table 6-28: USB Power Connector (USB_PWR1) Pinouts.....	102
Table 6-29: Rear Panel Connectors	103
Table 6-30: Ethernet Connectors (LAN2 & LAN3) Pinouts.....	103
Table 6-31: HDMI Connector (HDMI1) Pinouts.....	104
Table 6-32: Power Connector (PWR1) Pinouts.....	104
Table 6-33: RS-232/422/485 DB-9 Serial Port (COM1) Pinouts.....	104
Table 6-34: RS-232 RJ-45 Serial Port (COM2) Pinouts.....	105
Table 6-35: USB 3.0 Connectors (USB_CON12) Pinouts.....	105
Table 6-36: USB 3.0 Connectors (USB_CON2) Pinouts.....	106
Table 6-37: Preconfigured Jumpers	106
Table 6-38: LVDS Voltage Selection Jumper (J_VLVDS1) Settings	107
Table 6-39: LVDS Resolution Selection Jumper (SW1) Settings.....	107

List of BIOS Menus

BIOS Menu 1: Main	52
BIOS Menu 2: Advanced	53
BIOS Menu 3: ACPI Settings	54
BIOS Menu 4: F81866 Super IO Configuration	55
BIOS Menu 5: Serial Port n Configuration	55
BIOS Menu 6: F81866 H/W Monitor	60
BIOS Menu 7: RTC Wake Settings	61
BIOS Menu 8: Serial Port Console Redirection	62
BIOS Menu 9: Legacy Console Redirection Settings	63
BIOS Menu 10: Console Redirection Settings	64
BIOS Menu 11: CPU Configuration	66
BIOS Menu 12: SATA Configuration	68
BIOS Menu 13: USB Configuration	70
BIOS Menu 14: IEI Feature	71
BIOS Menu 15: Chipset	72
BIOS Menu 16: System Agent (SA) Configuration	72
BIOS Menu 17: Graphics Configuration	73
BIOS Menu 18: LCD Control	75
BIOS Menu 19: Memory Configuration	76
BIOS Menu 20: PCH-IO Configuration	76
BIOS Menu 21: PCI Express Configuration	77
BIOS Menu 22: HD Audio Configuration	78
BIOS Menu 23: Security	79
BIOS Menu 24: Boot	80
BIOS Menu 25: Exit	82

Chapter

1

Introduction

1.1 Overview



Figure 1-1: AFL3-W15C/W19C-ULT3 Flat Bezel Panel PC

The AFL3-W15C/W19C-ULT3 series is a quad-core Intel® Core™ i5-6300U or Intel® Celeron® 3955U powered flat bezel touchscreen panel PC with a rich variety of functions and peripherals. The flat-bezel design is ideal for easy and simplified integration into various applications.

The Intel® Core™ i5-6300U / Celeron® 3955U is a System-on-Chip (SoC) that ensures optimal memory, graphics, and peripheral I/O support. The system comes with 4.0 GB of DDR4 SO-DIMM memory ensuring smooth data throughputs with reduced bottlenecks and fast system access.

One RS-232/422/485 serial port, one RS-232 serial port and four external USB 3.0 ports ensure simplified connectivity to a variety of external peripheral devices. Wi-Fi capabilities and two RJ-45 Ethernet connectors provide the system with smooth connection to an external LAN.

1.2 Model Variations

There are several models in the AFL3-W15C/W19C-ULT3 series. The model numbers and model variations are listed below.

Model	Size	Processor	Touchscreen
AFL3-W15C-ULT3-C/R/4G	15.6"	Intel® Celeron® 3955U	5-wire resistive type
AFL3-W15C-ULT3-C/PC/4G	15.6"	Intel® Celeron® 3955U	Projected capacitive type
AFL3-W15C-ULT3-i5/R/4G	15.6"	Intel® Core™ i5-6300U	5-wire resistive type
AFL3-W15C-ULT3-i5/PC/4G	15.6"	Intel® Core™ i5-6300U	Projected capacitive type
AFL3-W19C-ULT3-C/PC/4G	18.5"	Intel® Celeron® 3955U	Projected capacitive type
AFL3-W19C-ULT3-i5/PC/4G	18.5"	Intel® Core™ i5-6300U	Projected capacitive type

Table 1-1: Model Variations

1.3 Features

The AFL3-W15C/W19C-ULT3 features are listed below:

- Flat-bezel LCD with LED backlight
- Intel® Core™ i5-6300U or Intel® Celeron® 3955U processor
- Preinstalled with 4 GB of DDR4 memory (system max. 32 GB)
- 5-wire resistive type or projected capacitive type touchscreen
- Wi-Fi 802.11a/b/g/n/ac high speed wireless
- Two PCIe GbE RJ-45 connectors
- Two internal speakers
- Four USB 3.0 ports
- One RS-232/422/485 serial port and one RS-232 serial port by D-sub 9 connectors
- Optional RFID reader
- Optional magnetic stripe card reader
- 9 V – 30 V wide range DC power input

- IP 64 compliant front panel

1.4 Front Panel

The front side of the AFL3-W15C/W19C-ULT3 is a flat-bezel panel with a TFT LCD screen surrounded by a PC/ABS plastic frame (**Figure 1-2**).

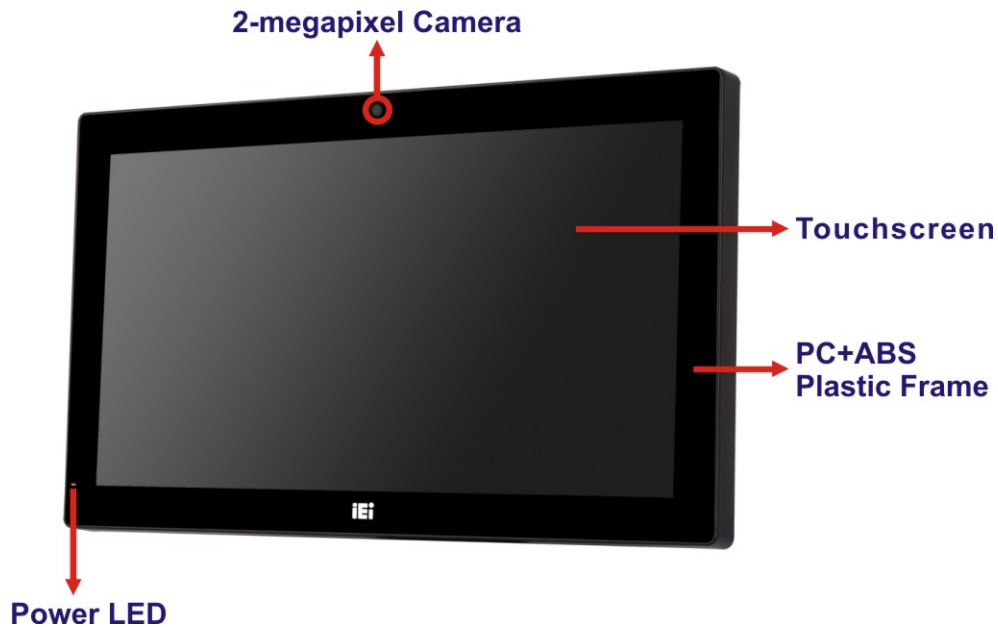

Figure 1-2: Front View

There is a power LED indicator located on the front panel. The status descriptions of the power LED indicator are listed below.

- **Off:** power cord not attached or power supply failure
- **Solid amber:** the system is connected to a power source and is ready to be turned on.
- **Solid green:** the system is turned on.

AFL3-W15C/W19C-ULT3 Panel PC

1.5 Bottom Panel

The bottom panel of the AFL3-W15C/W19C-ULT3 has the following connectors and switches (Figure 1-4).

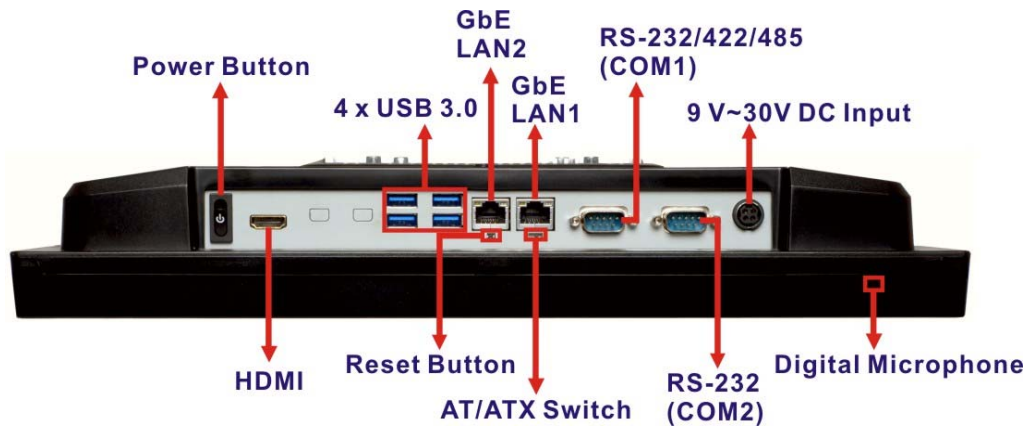

Figure 1-3: AFL3-W15C-ULT3 Bottom Panel

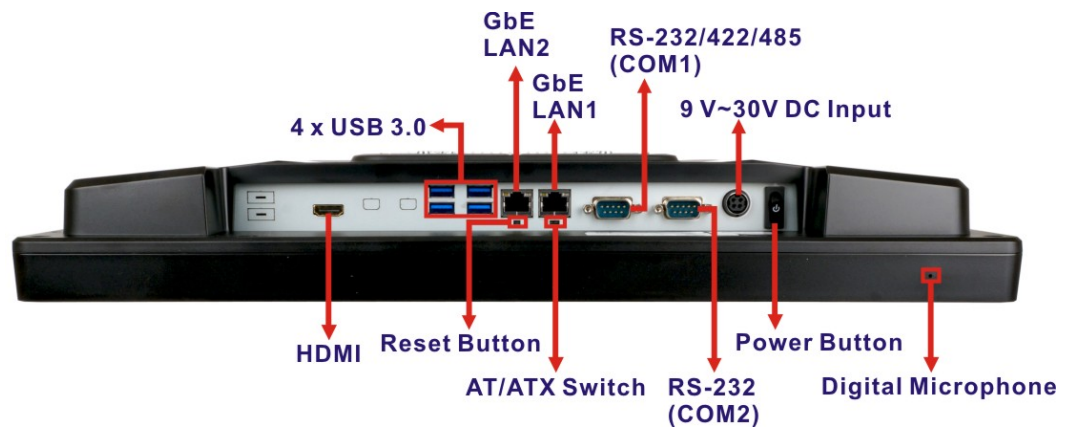

Figure 1-4: AFL3-W19C-ULT3 Bottom Panel

1.6 Rear Panel

The rear panel has two speakers and retention screw holes that support VESA mounting. The rear panel also has several retention screw holes for installing the optional barcode scanner and magnetic stripe card reader.

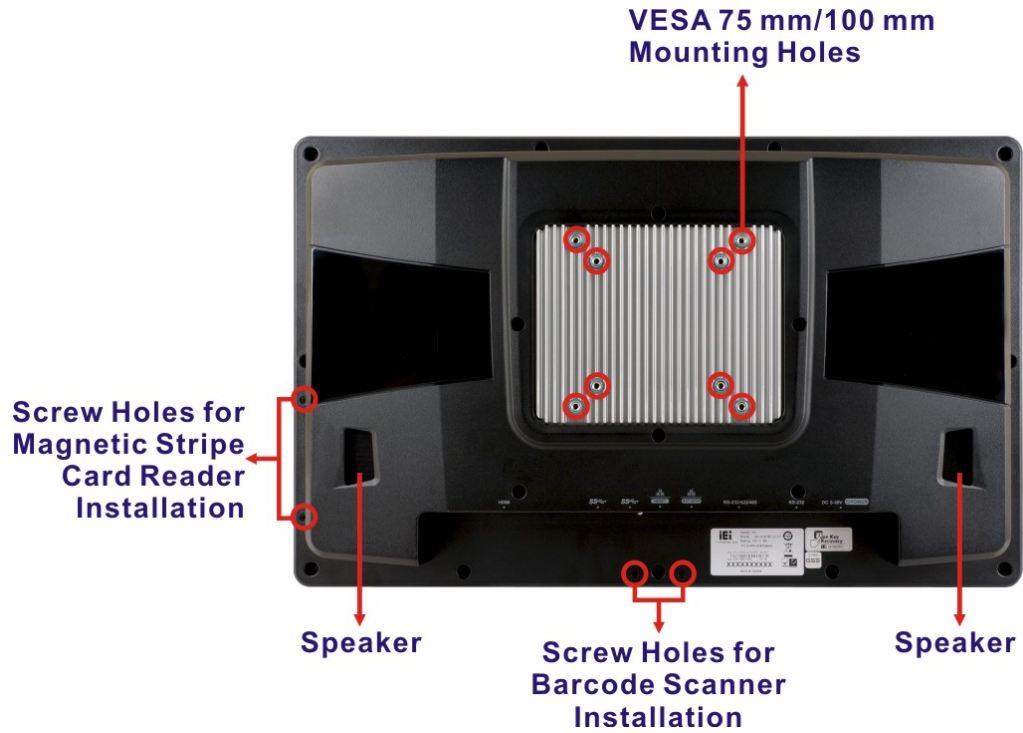

Figure 1-5: AFL3-W19C-ULT3 Rear View

AFL3-W15C/W19C-ULT3 Panel PC

1.7 System Specifications

The technical specifications for the AFL3-W15C/W19C-ULT3 systems are listed in **Table 1-2**.

Specification	AFL3-W15C-ULT3	AFL3-W19C-ULT3
LCD Size	15.6" (16:9)	18.5" (16:9)
Max. Resolution	1366 (W) x 768 (H)	1366 (W) x 768 (H)
Brightness (cd/m²)	300	250
Contrast Ratio	700:1	1000:1
LCD Color	16.7M	262K
Pixel Pitch (H x V) (mm)	0.240 x 0.240	0.240 x 0.240
Viewing Angle (H-V)	160° / 160°	170° / 160°
Backlight MTBF	50,000 hrs	30,000 hrs
Backlight	LED	LED
Touchscreen	5-wire resistive/ Projected capacitive	Projected capacitive
Touch Controller	Resistive: PenMount DMC9000 Capacitive: EETI EXC 7200	EETI EXC 3160
CPU (SoC)	Intel® Core™ i5-6300U or Intel® Celeron® 3955U	
Memory	Two 260-pin DDR4 SO-DIMM slots preinstalled with 4 GB SDRAM (system max. 32 GB)	
Ethernet	LAN1: Intel® I219-LM PHY with Intel® AMT 11.0 supported LAN2: Intel® I211-AT PCIe GbE controller	
Storage	One full-size/half-size PCIe Mini slot supports mSATA module One M.2 M-key slot for M.2 2280 module installation	

	One 2.5" SATA 3Gb/s HDD bay	
Audio	Realtek ALC892 HD Audio codec	
Internal Speaker	Two 3 W	
Camera	2-megapixel with low light function and digital microphone	
Wireless	One 802.11a/b/g/n/ac wireless LAN module (half-size PCIe Mini card)	
Bluetooth	Bluetooth v4.0	
RFID Reader	Mifare 13.56 MHz card reader (optional)	
Card Reader	Magnetic stripe card reader (optional)	
OSD Function	Controlled by OSD software	
Construction Material	PC+ABS plastic	
Thermal Design	Fanless	
VESA Mount	75 mm x 75 mm 100 mm x 100 mm	
Mounting	Panel, wall, rack, stand or arm mounting	
Front Panel Color	Black C	
Net/Gross Weight	4.5 kg / 6.5 kg	7.3 kg / 10 kg
Dimensions (W x H x D)	396 mm x 250 mm x 64 mm	472 mm x 292 mm x 68 mm
Operating Temperature	-20°C ~ 50°C	
Storage Temperature	-20°C ~ 60°C	
Humidity	10% ~ 95% (non-condensing)	
IP Level	IP 64 compliant front panel	
Safety/EMC	CE, FCC	
Power Supply	96 W power adapter	

AFL3-W15C/W19C-ULT3 Panel PC

Input:	100 V ~ 240 V AC, 50 Hz ~ 60 Hz	
Output:	12 V DC, 8 A	
Power Requirement	9 V ~ 30 V DC	
Power Consumption	56 W, 12 V @ 4.6 A	86 W, 12 V @ 7.1 A
I/O Ports and Switches	1 x RS-232/422/485 serial port (DB-9 connector) 1 x RS-232 serial port (DB-9 connector) 2 x GbE LAN (RJ-45 connector) 4 x USB 3.0 connectors 1 x HDMI output connector 1 x Power switch 1 x AT/ATX switch 1 x Reset button 1 x 9 V ~ 30 V DC input jack	

Table 1-2: System Specifications

1.8 Dimensions

The following sections list the dimensions of each model.

1.8.1 AFL3-W15C-ULT3 Dimensions

The AFL3-W15C-ULT3 dimensions are shown below.

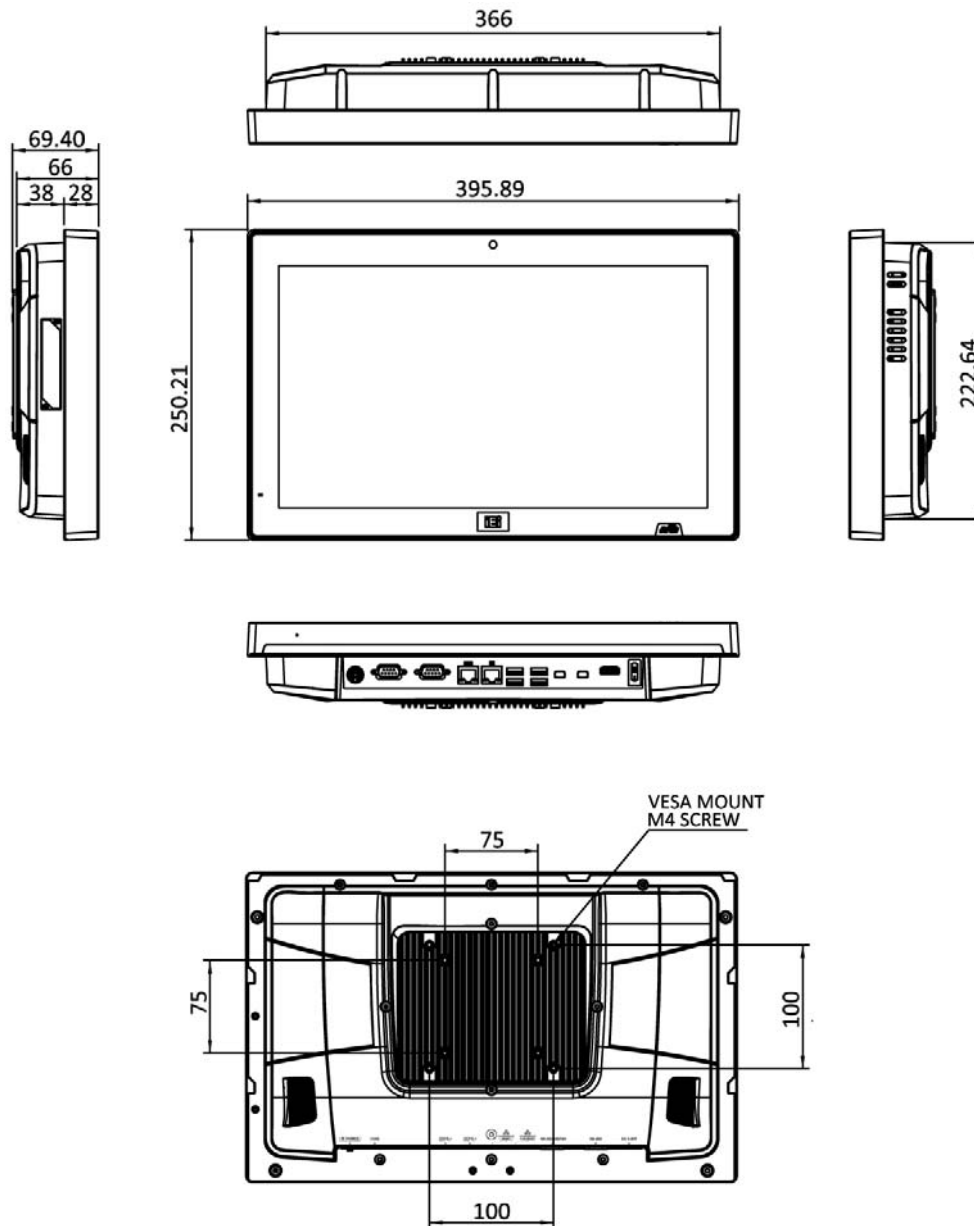

Figure 1-6: AFL3-W15C-ULT3 Dimensions (mm)

AFL3-W15C/W19C-ULT3 Panel PC

1.8.2 AFL3-W19C-ULT3 Dimensions

The AFL3-W19C-ULT3 dimensions are shown below.

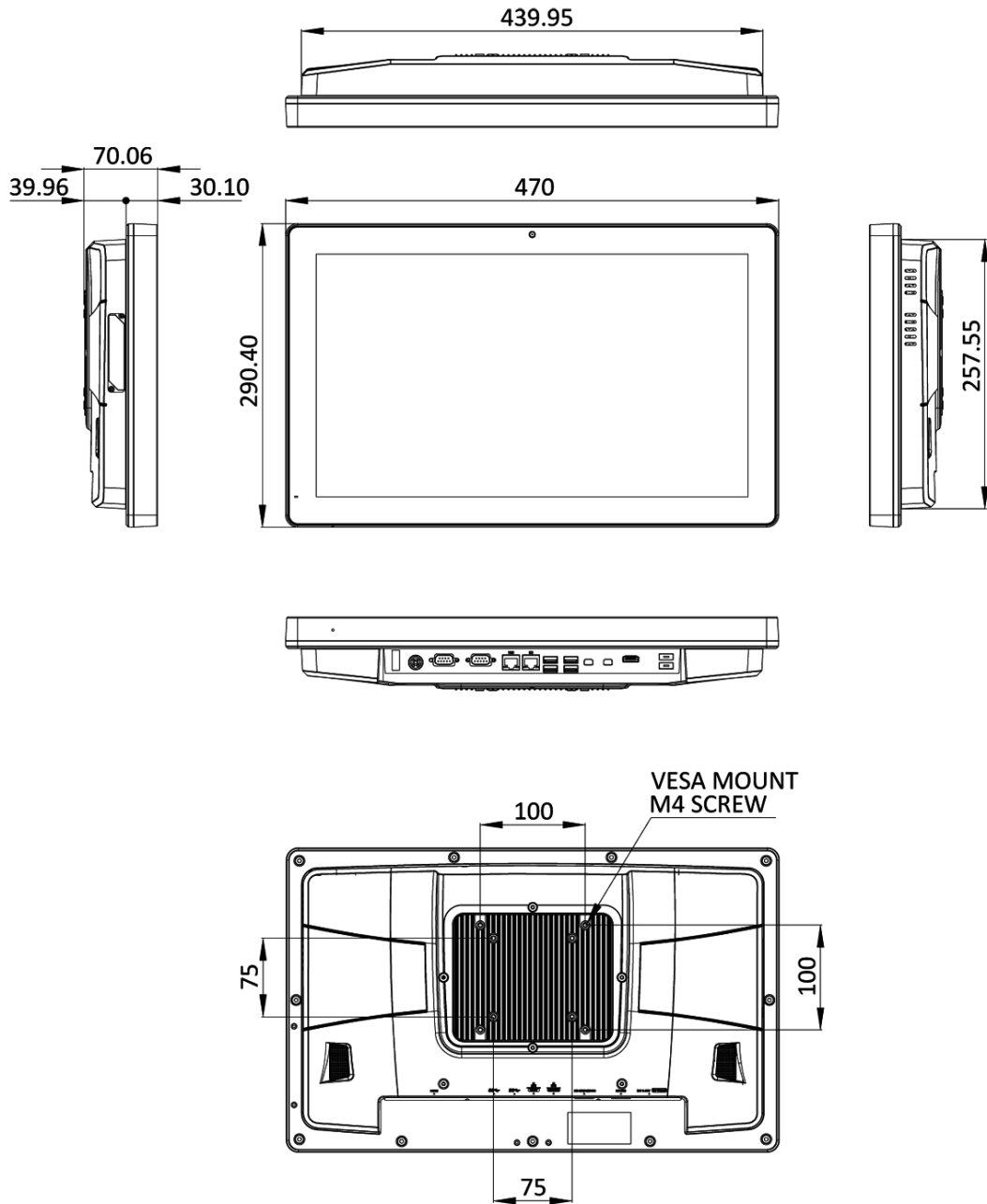

Figure 1-7: AFL3-W19C-ULT3 Dimensions (mm)

Chapter

2

Unpacking

AFL3-W15C/W19C-ULT3 Panel PC

2.1 Unpacking

To unpack the flat bezel panel PC, follow the steps below:



WARNING!

The front side LCD screen has a protective plastic cover stuck to the screen. Only remove the plastic cover after the flat bezel panel PC has been properly installed. This ensures the screen is protected during the installation process.

Step 1: Carefully cut the tape sealing the box. Only cut deep enough to break the tape.

Step 2: Open the outside box.

Step 3: Carefully cut the tape sealing the box. Only cut deep enough to break the tape.

Step 4: Open the inside box.

Step 5: Lift the panel PC out of the boxes.

Step 6: Remove the peripheral parts box from the main box.

2.2 Packing List









NOTE:

If any of the components listed in the checklist below are missing, do not proceed with the installation. Contact the IEI reseller or vendor the AFL3-W15C/W19C-ULT3 was purchased from or contact an IEI sales representative directly by sending an email to sales@ieiworld.com.

AFL3-W15C/W19C-ULT3 Panel PC

The AFL3-W15C/W19C-ULT3 flat bezel panel PC is shipped with the following components:

Quantity	Item	Image
1	AFL3-W15C/W19C-ULT3 panel PC	
1	96 W power adapter (P/N: 63040-010096-100-RS)	
1	Power cord	
4	Screws for VESA mounting	
4	Screws for HDD installation	
1	Utility CD	
1	One Key Recovery CD	

AFL3-W15C/W19C-ULT3 Panel PC

2.3 Optional Items

The following are optional components which may be separately purchased:

Item and Part Number	Image
VESA 100 wall mount kit (P/N: AFLWK-19B)	
Panel mounting kit (P/N: AFL3PK-W07A-R10)	
Rack mounting kit	
Arm (P/N: ARM-11-RS)	
Arm (P/N: ARM-31-RS)	

Item and Part Number	Image
Stand for VESA 100 (P/N: STAND-A19-RS)	
Stand for VESA 75/VESA 100 (P/N: STAND-C19-R10)	
Magnetic card reader (P/N: AFL3P-W10MSR-U-R10)	
Barcode scanner (P/N: AFL3-2D-R10)	

If any of these items are missing or damaged, contact the distributor or sales representative immediately.

Chapter

3

Installation

3.1 Anti-static Precautions

**WARNING:**

Failure to take ESD precautions during the maintenance of the AFL3-W15C/W19C-ULT3 may result in permanent damage to the AFL3-W15C/W19C-ULT3 and severe injury to the user.

Electrostatic discharge (ESD) can cause serious damage to electronic components, including the AFL3-W15C/W19C-ULT3. Dry climates are especially susceptible to ESD. It is therefore critical that whenever the AFL3-W15C/W19C-ULT3 is accessed internally, or any other electrical component is handled, the following anti-static precautions are strictly adhered to.

- **Wear an anti-static wristband:** Wearing a simple anti-static wristband can help to prevent ESD from damaging the board.
- **Self-grounding:** Before handling the board, touch any grounded conducting material. During the time the board is handled, frequently touch any conducting materials that are connected to the ground.
- **Use an anti-static pad:** When configuring the AFL3-W15C/W19C-ULT3, place it on an anti-static pad. This reduces the possibility of ESD damaging the AFL3-W15C/W19C-ULT3.
- **Only handle the edges of the PCB:** When handling the PCB, hold the PCB by the edges.

3.2 Installation Precautions

When installing the flat bezel panel PC, please follow the precautions listed below:

- **Power turned off:** When installing the flat bezel panel PC, make sure the power is off. Failing to turn off the power may cause severe injury to the body and/or damage to the system.
- **Certified Engineers:** Only certified engineers should install and modify onboard functionalities.

AFL3-W15C/W19C-ULT3 Panel PC

- **Anti-static Discharge:** If a user open the rear panel of the flat bezel panel PC, to configure the jumpers or plug in added peripheral devices, ground themselves first and wear an anti-static wristband.

3.3 Installation and Configuration Steps

The following installation steps must be followed.

- Step 1:** Unpack the flat bezel panel PC.
- Step 2:** Install an mSATA module or a HDD.
- Step 3:** Configure the system.
- Step 4:** Connect peripheral devices to the flat bezel panel PC.
- Step 5:** Mount the flat bezel panel PC.

3.4 Removing the Back Covers

To access the AFL3-W15C/W19C-ULT3 internally the plastic back cover and the internal aluminum cover must be removed. To remove the covers, please follow the steps below.

- Step 1:** Remove the retention screws from the back cover. Two types of screw are used for securing the plastic cover of the AFL3-W15C-ULT3. See **Figure 3-1** for detail. Be aware of this for reinstalling the plastic cover.



Figure 3-1: AFL3-W15C-ULT3 Back Cover Retention Screws



Figure 3-2: AFL3-W19C-ULT3 Back Cover Retention Screws

Step 2: Lift the plastic back cover off the AFL3-W15C/W19C-ULT3.

Step 3: Remove the retention screws from the internal aluminum cover. Two types of screw are used for securing the aluminum cover. See the following diagrams for detail. Be aware of this for reinstalling the aluminum cover.

For 15" panel PC: see **Figure 3-3**

For 19" panel PC: see **Figure 3-4**





-  : Pan head screw
-  : Round head screw with washers

Figure 3-3: AFL3-W15C-ULT3 Aluminum Cover Retention Screws

AFL3-W15C/W19C-ULT3 Panel PC

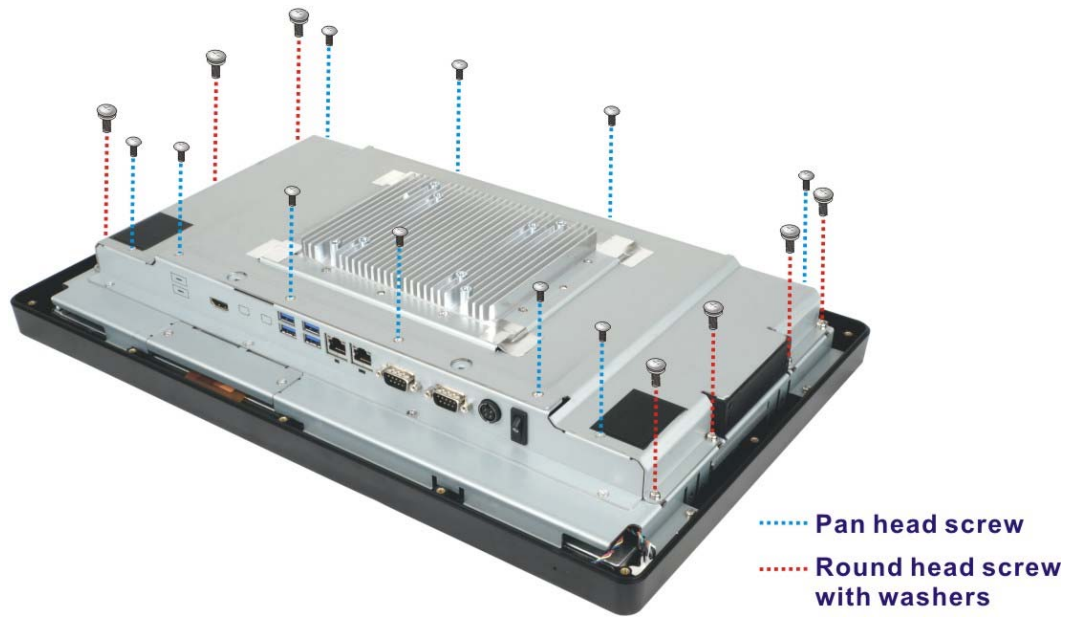

Figure 3-4: AFL3-W19C-ULT3 Aluminum Cover Retention Screws

Step 4: Lift the aluminum cover off the AFL3-W15C/W19C-ULT3. A thermal pad is attached under the center of the aluminum cover. To easily remove the cover, turn the cover in a clockwise direction first to detach the thermal pad before lifting the cover (Figure 3-5).



Figure 3-5: Lift the Aluminum Cover

3.5 M.2 Module Installation

The AFL3-W15C/W19C-ULT3 has an M.2 M-key slot for M.2 2280 module installation. To install an M.2 module into the AFL3-W15C/W19C-ULT3, please follow the steps below:

Step 1: Remove the plastic back cover and the internal aluminum cover. See **Section 3.4** above.

Step 2: Locate the M.2 slot. Remove the preinstalled retention screw on the motherboard as shown in **Figure 3-6**.

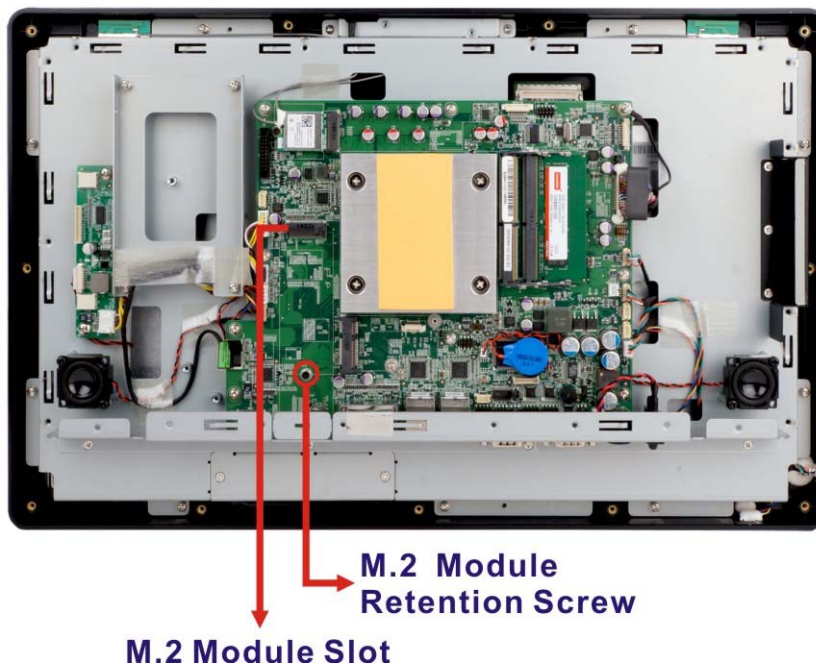

Figure 3-6: M.2 Module Slot Location

Step 3: Line up the notch on the card with the notch on the slot. Slide the PCIe Mini card into the socket at an angle of about 20° (**Figure 3-7**).

AFL3-W15C/W19C-ULT3 Panel PC

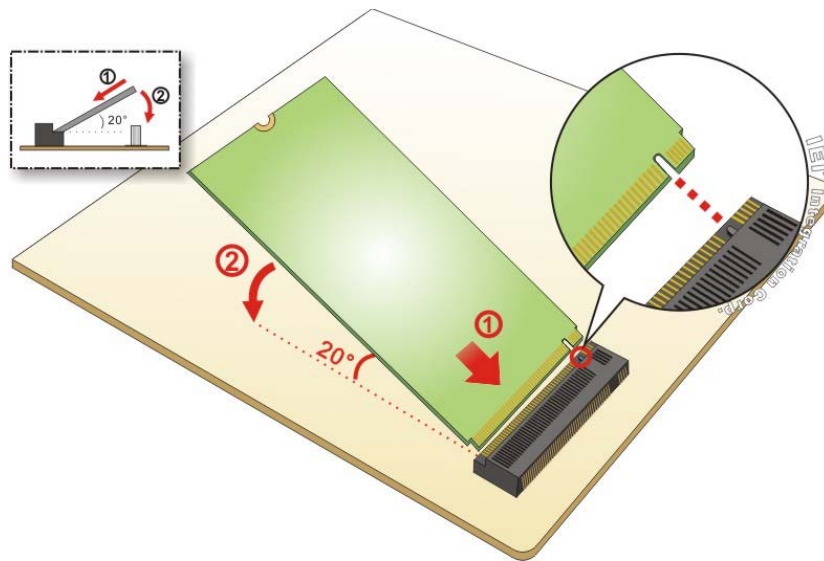

Figure 3-7: Inserting the M.2 Module into the Slot at an Angle

Step 4: Secure the M.2 module with the previously removed retention screw (Figure 3-8).

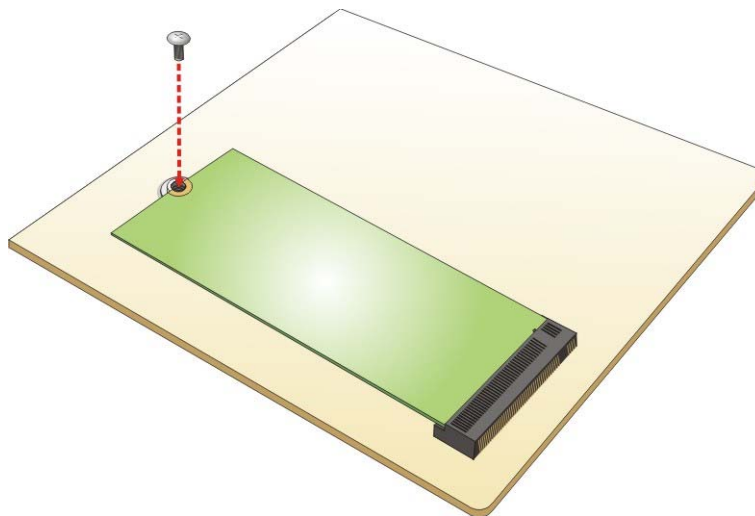

Figure 3-8: Securing the M.2 Module

3.6 mSATA Module Installation (Full-Size)

To install an full-size mSATA module into the AFL3-W15C/W19C-ULT3, please follow the steps below:

- Step 1:** Remove the plastic back cover and the internal aluminum cover. See **Section 3.4** above.
- Step 2:** Locate the mSATA module slot. Remove the preinstalled retention screw on the screw pillar as shown in **Figure 3-9**.

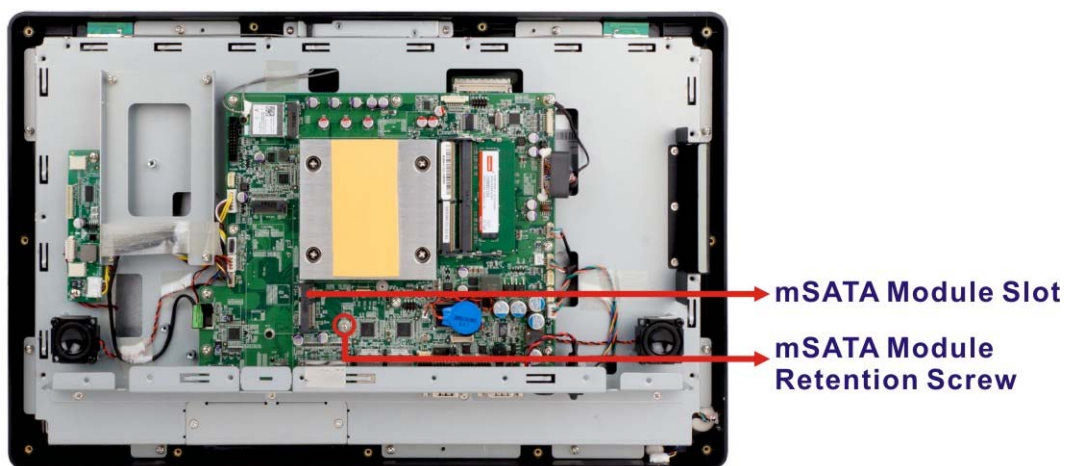

Figure 3-9: mSATA Module Slot Location

- Step 3:** To avoid interference of the board circuit, remove the retention screw and standoff for a half-size PCIe Mini card as shown in **Figure 3-10**.

AFL3-W15C/W19C-ULT3 Panel PC

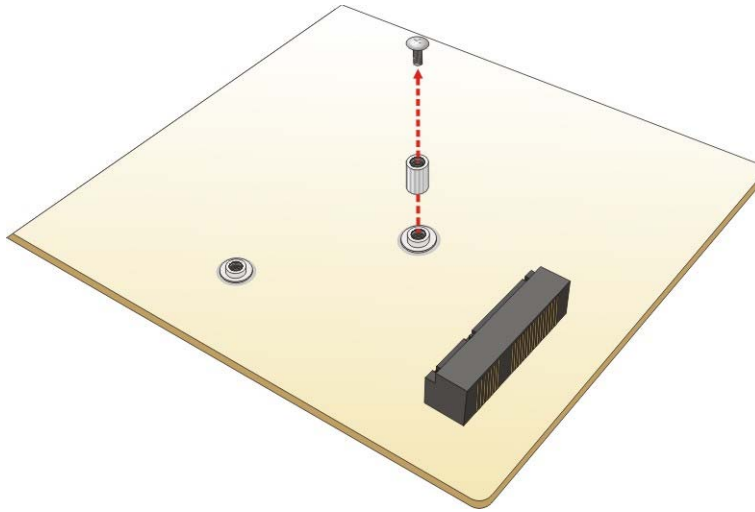

Figure 3-10: Removing the Retention Screw and Standoff

Step 4: Install the previously removed standoff to the screw hole for the full-size PCIe Mini card (**Figure 3-11**).

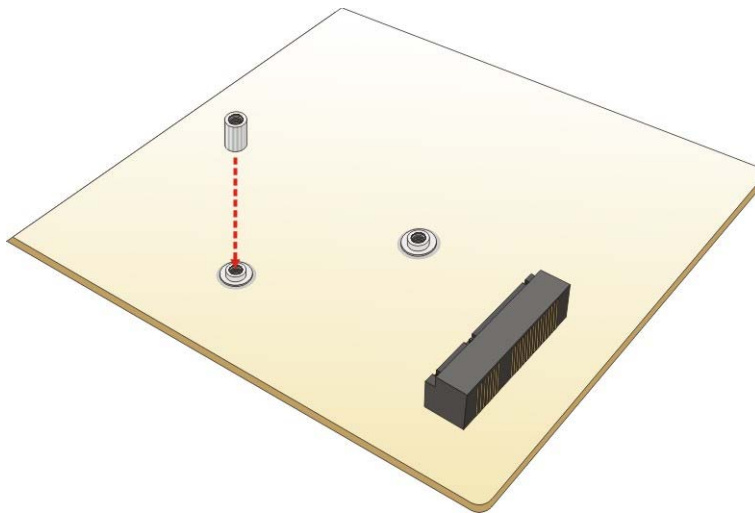

Figure 3-11: Installing the Standoff

Step 5: Line up the notch on the mSATA module with the notch on the connector. Slide the PCIe Mini card into the socket at an angle of about 20° (**Figure 3-12**).

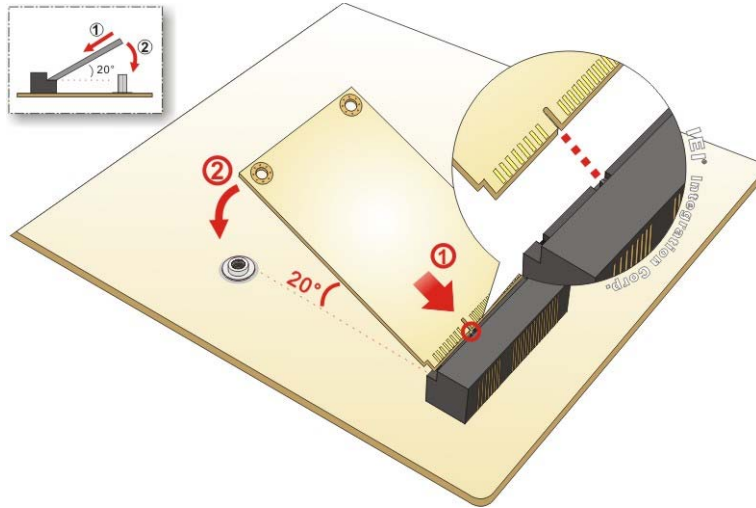

Figure 3-12: Installing an mSATA Module

Step 6: Secure the mSATA module with the retention screw. Push the other end of the mSATA module down and secure the module with the previously removed retention screw (**Figure 3-12**).

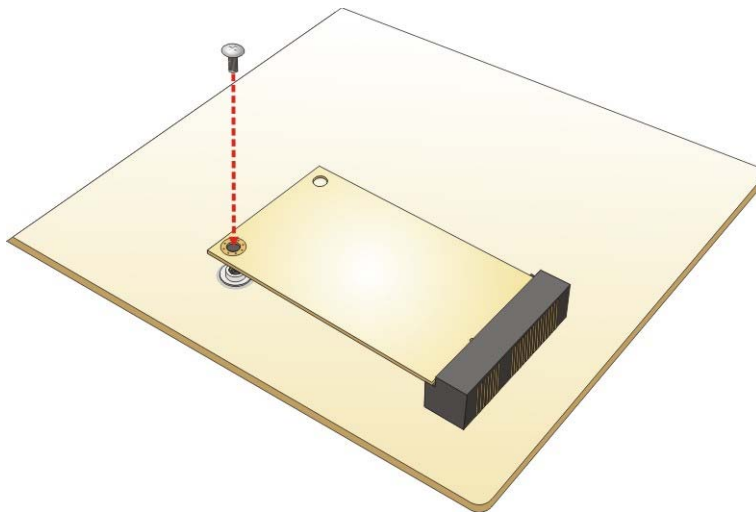

Figure 3-13: Securing the mSATA Module

Step 7: Re-install the aluminum cover and the plastic back cover.

AFL3-W15C/W19C-ULT3 Panel PC



NOTE:

To install a half-size mSATA module, simply remove the pre-installed retention screw of the PCIe Mini card slot and insert the half-size mSATA module into the socket. Then, secure the module with the previously removed retention screw.

3.7 HDD Installation

To install the HDD into the system, please follow the steps below:

- Step 1:** Remove the plastic back cover and the internal aluminum cover. See **Section 3.4** above.
- Step 2:** Remove the four HDD bracket retention screws and lift the HDD bracket off the panel PC.



Figure 3-14: HDD Bracket Retention Screws

- Step 3:** Attach the HDD brackets to the HDD. To do this, align the four retention screw holes in the both sides of the HDD bracket with the retention screw holes on the

sides of the HDD. Insert four retention screws into the HDD bracket (Figure 3-15).

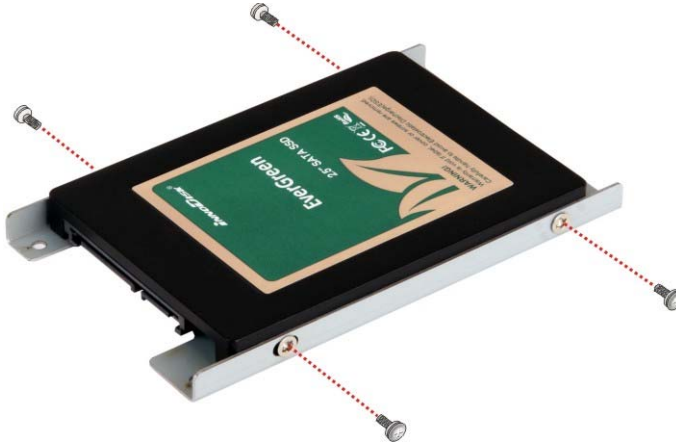

Figure 3-15: HDD Retention Screws

Step 4: Connect the SATA cable to the rear of HDD from the motherboard.

Step 5: Install the HDD into the AFL3-W15C/W19C-ULT3 by aligning the retention screw holes in the HDD brackets with the retention screw holes on the chassis. Insert the four retention screws.

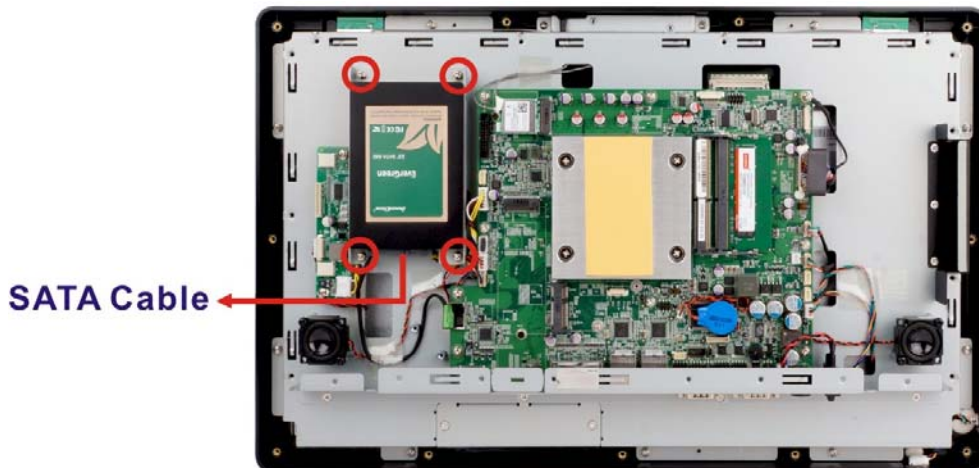

Figure 3-16: HDD Installation

Step 6: Replace the internal aluminum cover and the plastic back cover.

AFL3-W15C/W19C-ULT3 Panel PC

3.8 DB-9 Serial Port Pin 9 Selection

Pin 9 on the COM1 and COM2 DB-9 connectors can be set as the ring (RI) signal, +5 V or +12 V. The jumper selection options are shown in **Table 3-1** and **Table 3-2**.

JP5	Description
Short 1-2	COM1 RI Pin use +12 V
Short 3-4	COM1 RI Pin use RI (Default)
Short 5-6	COM1 RI Pin use +5 V

Table 3-1: COM1 Pin 9 Setting Jumper Settings (JP5)

JP4	Description
Short 1-2	COM2 RI Pin use +12 V
Short 3-4	COM2 RI Pin use RI (Default)
Short 5-6	COM2 RI Pin use +5 V

Table 3-2: COM2 Pin 9 Setting Jumper Settings (JP4)

The DB-9 Serial Port Pin 9 Setting jumper locations are shown in **Figure 3-17** below.

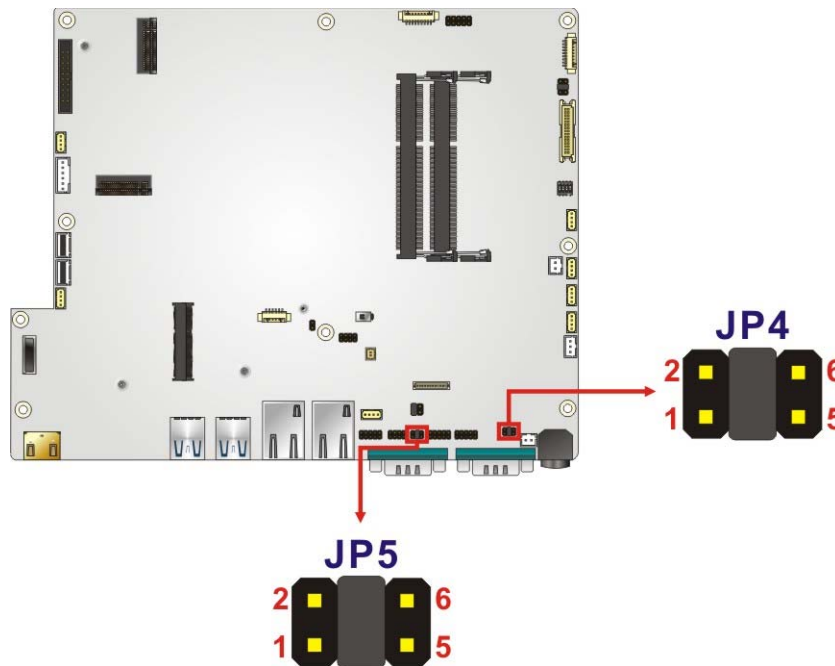

Figure 3-17: DB-9 Serial Port Pin 9 Setting Jumper Locations

3.9 RS-232/422/485 Serial Port Selection

The COM1_SEL1 and JP3 jumpers set the communication protocol used by the COM1 DB-9 serial communication port as RS-232, RS-422 or RS-485. The RS-232/422/485 serial port selection settings are shown in **Table 3-3** and **Table 3-4**.

COM1_SEL1	Description
Open	RS-232 (Default)
Short 1-2, 3-4, 5-6, 7-8	RS-422/RS-485

Table 3-3: RS-232/422/485 Selection Jumper Settings (COM1_SEL1)

JP3	Description
Short 1-2	RS-232 (Default)
Short 1-2, 3-4	RS-422
Short 3-4	RS-485

Table 3-4: RS-232/422/485 Selection Jumper Settings (JP3)

The RS-232/422/485 selection jumper locations are shown in **Figure 3-18**.

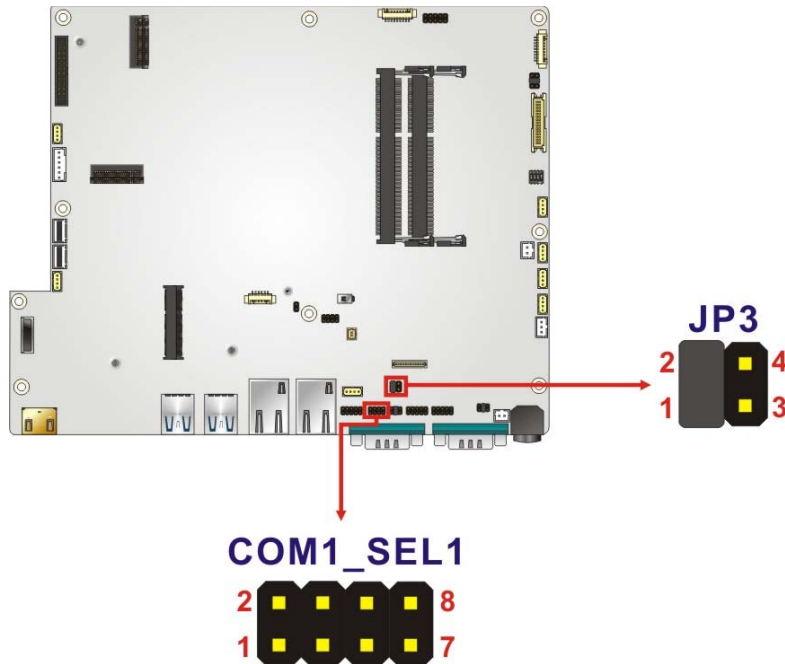

Figure 3-18: RS-232/422/485 Selection Jumper Locations

AFL3-W15C/W19C-ULT3 Panel PC

3.9.1 COM1 Pinouts

The pinouts of COM1 external serial port are detailed below.

PIN NO.	RS-232	RS-422	RS-485
1	DCD	TXD422-	TXD485-
2	RXD	TXD422+	TXD485+
3	TXD	RXD422+	--
4	DTR	RXD422-	--
5	GND	--	--
6	DSR	--	--
7	RTS	--	--
8	CTS	--	--
9	RI	--	--

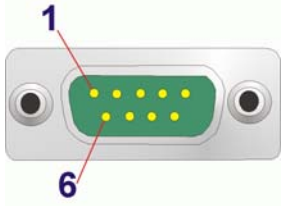

Table 3-5: RS-232/422/485 Serial Port (COM1) Pinouts

3.10 Clear CMOS

If the AFL3-W15C/W19C-ULT3 fails to boot due to improper BIOS settings, the clear CMOS jumper clears the CMOS data and resets the system BIOS information. To do this, push the clear CMOS button for three seconds, then restart the system. The clear CMOS button location is shown in **Figure 3-19**.

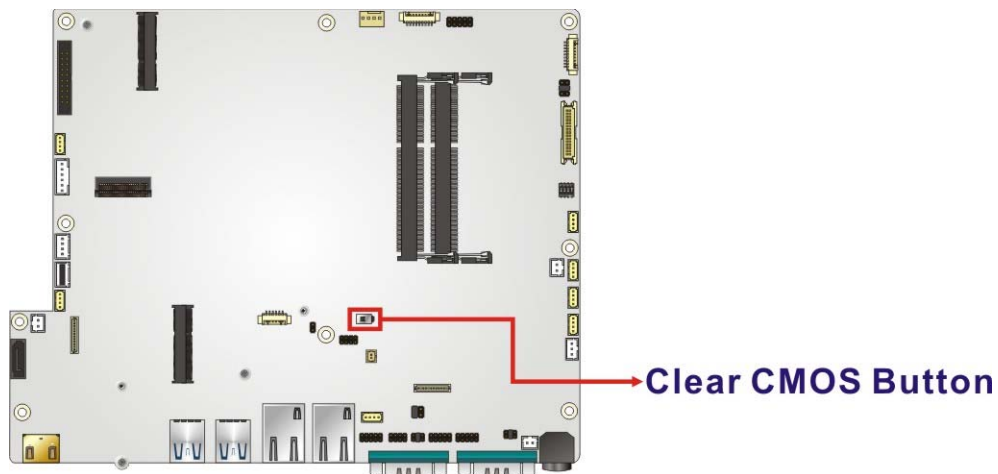

Figure 3-19: Clear CMOS Button Location

3.11 AT/ATX Mode Selection

AT or ATX power mode can be used on the AFL3-W15C/W19C-ULT3. The selection is made through an AT/ATX switch located on the bottom panel (**Figure 3-20**).

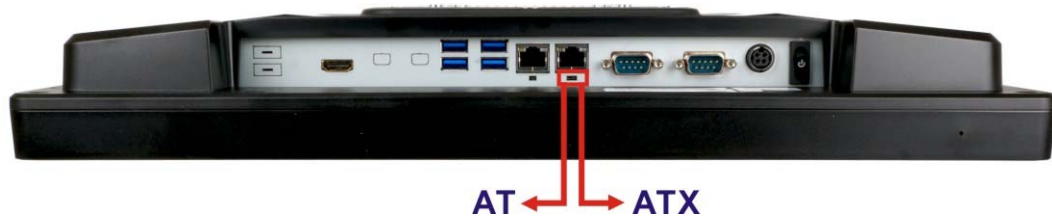

Figure 3-20: AT/ATX Switch Location

3.11.1 AT Power Mode

With the AT mode selected, the power is controlled by a central power unit rather than a power switch. The AFL3-W15C/W19C-ULT3 panel PC turns on automatically when the power is connected. The AT mode benefits a production line to control multiple panel PCs from a central management center and other applications including:

- ATM
- Self-service kiosk
- Plant environment monitoring system
- Factory automation platform
- Manufacturing shop flow

3.11.2 ATX Power Mode

With the ATX mode selected, the AFL3-W15C/W19C-ULT3 panel PC goes in a standby mode when it is turned off. The panel PC can be easily turned on via network or a power switch in standby mode. Remote power control is perfect for advertising applications since the broadcasting time for each panel PC can be set individually and controlled remotely. Other possible application includes

- Security surveillance
- Point-of-Sale (POS)
- Advertising terminal

AFL3-W15C/W19C-ULT3 Panel PC

3.12 Mounting the System

The methods of mounting the AFL3-W15C/W19C-ULT3 are listed below.

- Wall mounting
- Panel mounting
- Rack mounting
- Arm mounting
- Stand mounting

The mounting methods are described below.

3.12.1 Wall Mounting

To mount the flat bezel panel PC onto the wall, please follow the steps below.

- Step 1:** Select the location on the wall for the wall-mounting bracket.
- Step 2:** Carefully mark the locations of the four screw holes in the bracket on the wall.
- Step 3:** Drill four pilot holes at the marked locations on the wall for the bracket retention screws.
- Step 4:** Align the wall-mounting bracket screw holes with the pilot holes.
- Step 5:** Secure the mounting-bracket to the wall by inserting the retention screws into the four pilot holes and tightening them (**Figure 3-21**).

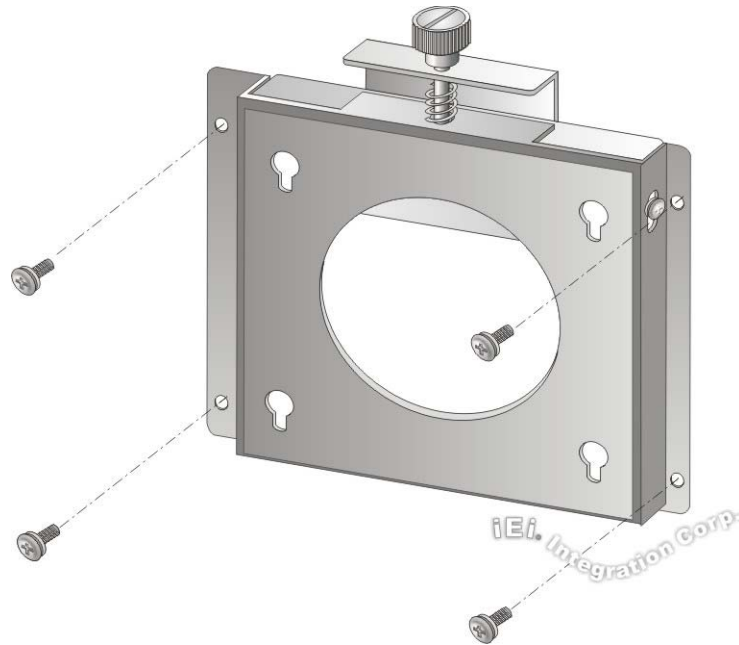

Figure 3-21: Wall-mounting Bracket

Step 6: Insert the four monitor mounting screws provided in the wall mount kit into the four screw holes on the rear panel of the flat bezel panel PC and tighten until the screw shank is secured against the rear panel (**Figure 3-22**).



WARNING:

Please use the M4 screws provided in the wall mount kit for the rear panel. If the screw is missing, the thread depth of the replacement screw should be not more than 4 mm.

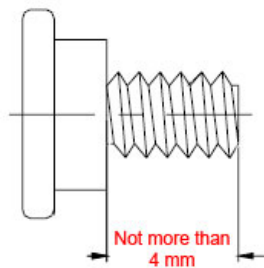

AFL3-W15C/W19C-ULT3 Panel PC

Step 7: Align the mounting screws on the monitor rear panel with the mounting holes on the bracket.

Step 8: Carefully insert the screws through the holes and gently pull the monitor downwards until the monitor rests securely in the slotted holes (**Figure 3-22**). Ensure that all four of the mounting screws fit snugly into their respective slotted holes.



NOTE:

In the diagram below the bracket is already installed on the wall.

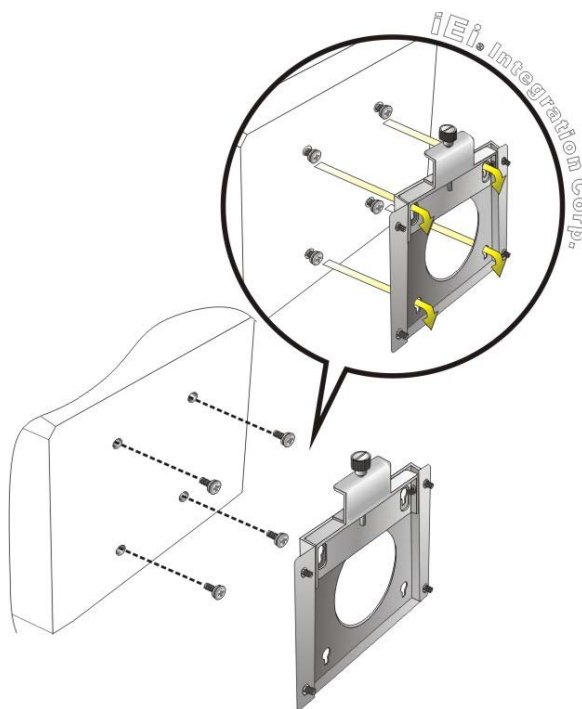

Figure 3-22: Chassis Support Screws

Step 9: Secure the panel PC by fastening the retention screw of the wall-mounting bracket (**Figure 3-23**).

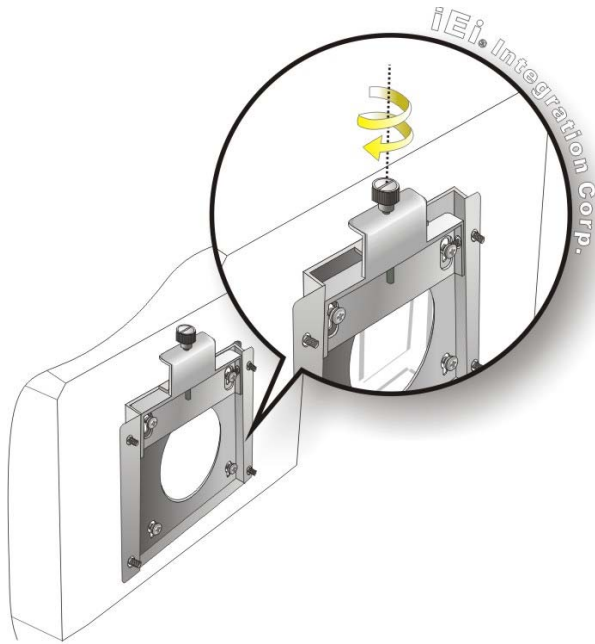

Figure 3-23: Secure the Panel PC

3.12.2 Panel Mounting

To mount the AFL3-W15C/W19C-ULT3 flat bezel panel PC into a panel, please follow the steps below.

- Step 1:** Select the position on the panel to mount the panel PC.
- Step 2:** Cut out a section corresponding to the size shown below. The size must be smaller than the outer edge.

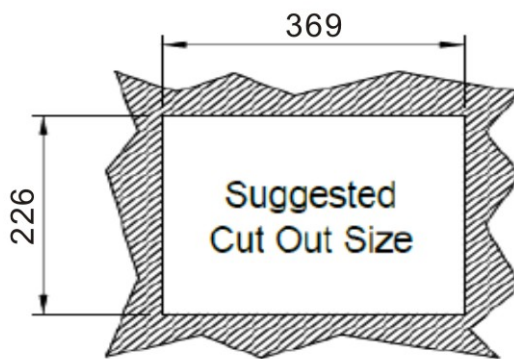

Figure 3-24: AFL3-W15C-ULT3 Cutout Dimensions

AFL3-W15C/W19C-ULT3 Panel PC

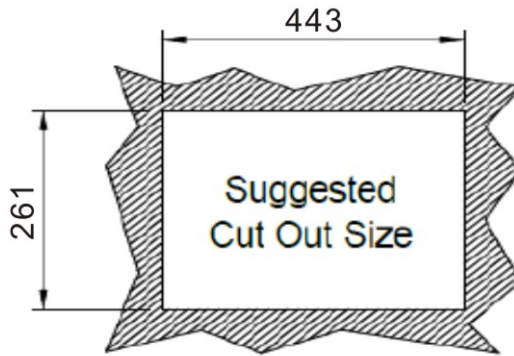





Figure 3-25: AFL3-W19C-ULT3 Cutout Dimensions

Step 3: Slide the panel PC through the hole until the frame is flush against the panel.

Step 4: Insert a M5*50 screw into the screw hole on the side of the panel mounting bracket. Then, install the following components onto the screw in sequence.

See **Figure 3-26**.

Sequence	Item	Photo	Instruction
1	Spring		Install a spring onto the screw.
2	Nut		Tighten a nut until the spring is compressed enough for plastic cap.
3	Plastic cap		Tighten a plastic cap onto the end of screw thread.

Step 5: Repeat **Step 4** to install the other three screws into the sides of the two panel mounting brackets.

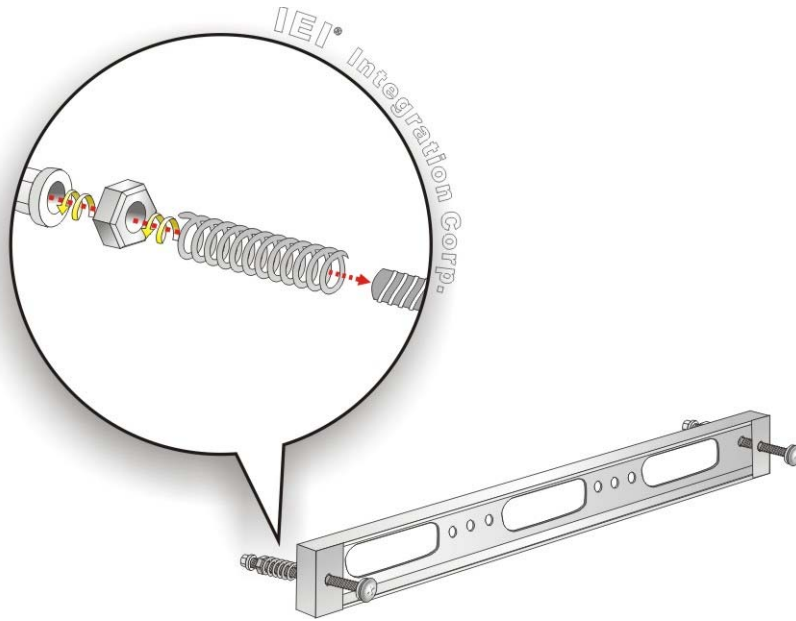

Figure 3-26: Panel Mounting Kit Installation

- Step 6:** Align the panel mounting bracket screw holes with the VESA mounting holes on the rear of the panel PC.
- Step 7:** Secure the two panel mounting brackets to the rear of the panel PC by inserting the four retention screws into the VESA mounting holes and tightening them (Figure 3-27).

AFL3-W15C/W19C-ULT3 Panel PC

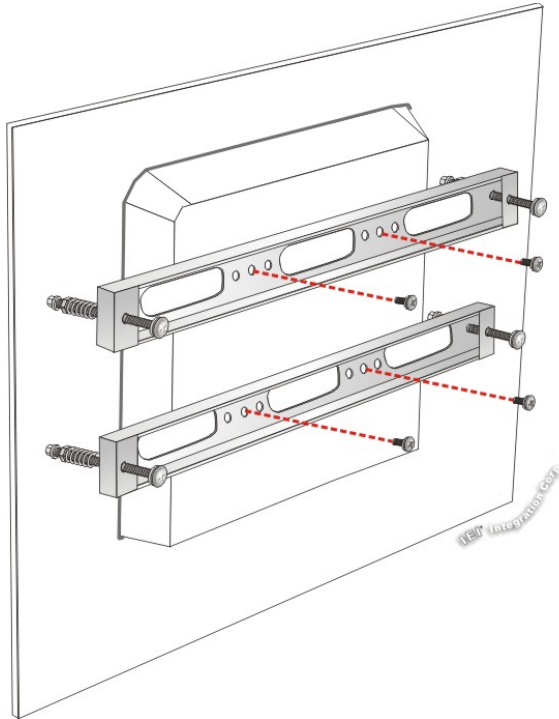

Figure 3-27: Securing Panel Mounting Brackets



NOTE:

The panel mounting kit described in this section is an optional item. To purchase it, please contact an IEI sales representative.

3.12.3 Cabinet and Rack Installation

The AFL3-W15C/W19C-ULT3 flat bezel panel PC can be installed into a cabinet or rack. The installation procedures are similar to the panel mounting installation. To do this, please follow the steps below:





NOTE:

When purchasing the cabinet/rack installation bracket, make sure it is compatible with both the AFL3-W15C/W19C-ULT3 flat bezel panel PC and the rack/cabinet into which the AFL3-W15C/W19C-ULT3 is installed.

Step 1: Slide the rear chassis of the AFL3-W15C/W19C-ULT3 panel PC through the rack/cabinet bracket until the frame is flush against the front of the bracket.

Step 2: Insert a M5*50 screw into the screw hole on the side of the rack mounting bracket. Then, install the following components onto the screw in sequence.

See **Figure 3-26**.

Sequence	Item	Photo	Instruction
1	Spring		Install a spring onto the screw.
2	Nut		Tighten a nut until the spring is compressed enough for plastic cap.
3	Plastic cap		Tighten a plastic cap onto the end of screw thread.

Step 3: Repeat **Step 4** to install the other three screws into the sides of the two rack mounting brackets.

AFL3-W15C/W19C-ULT3 Panel PC

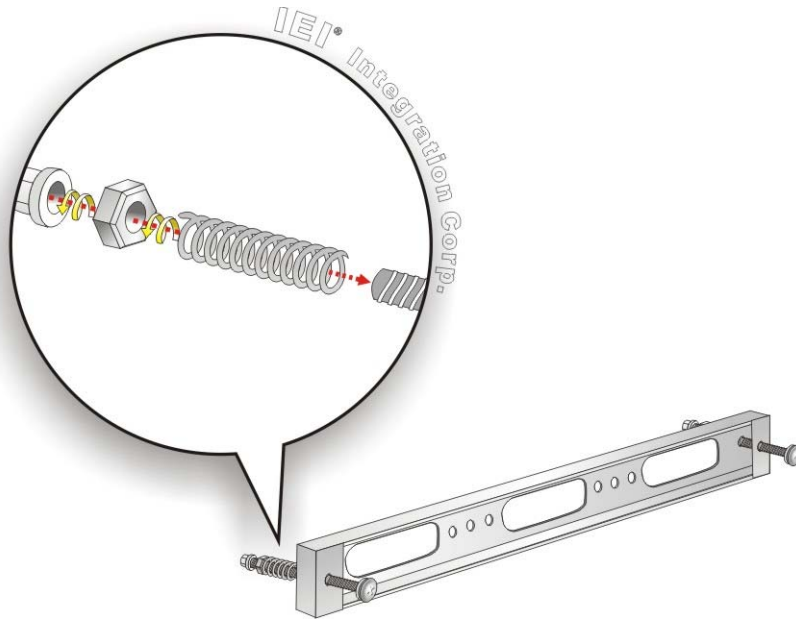

Figure 3-28: Rack Mounting Kit Installation

- Step 4:** Align the rack mounting bracket screw holes with the VESA mounting holes on the rear of the panel PC.
- Step 5:** Secure the two rack mounting brackets to the rear of the panel PC by inserting the four retention screws into the VESA mounting holes and tightening them (Figure 3-29).

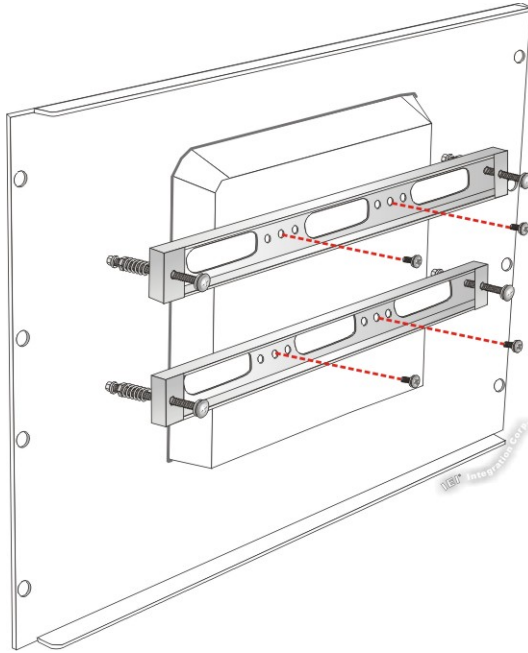

Figure 3-29: Securing Rack Mounting Brackets

Step 6: Slide the panel PC with the attached rack/cabinet bracket into a rack or cabinet (Figure 3-30).

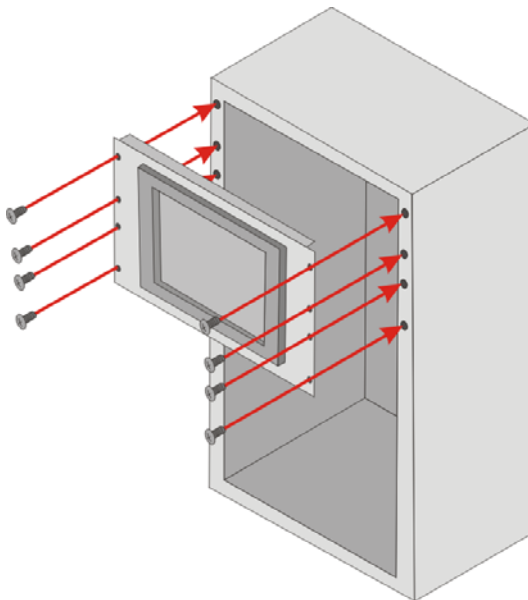

Figure 3-30: Install into a Rack/Cabinet

AFL3-W15C/W19C-ULT3 Panel PC

Step 7: Once the panel PC with the attached rack/cabinet bracket has been properly inserted into the rack or cabinet, secure the front of the rack/cabinet bracket to the front of the rack or cabinet (**Figure 3-30**).



NOTE:

The rack mounting kit described in this section is an optional item. To purchase it, please contact an IEI sales representative.

3.12.4 Arm Mounting

The AFL3-W15C/W19C-ULT3 is VESA (Video Electronics Standards Association) compliant and can be mounted on an arm with a 75 mm or a 100 mm interface pad. To mount the AFL3-W15C/W19C-ULT3 on an arm, please follow the steps below.

Step 1: The arm is a separately purchased item. Please correctly mount the arm onto the surface it uses as a base. To do this, refer to the installation documentation that came with the mounting arm.



NOTE:

When purchasing the arm please ensure that it is VESA compliant and that the arm has a 75 mm or a 100 mm interface pad. If the mounting arm is not VESA compliant it cannot be used to support the AFL3-W15C/W19C-ULT3 flat bezel panel PC.

Step 2: Once the mounting arm has been firmly attached to the surface, lift the flat bezel panel PC onto the interface pad of the mounting arm.

Step 3: Align the retention screw holes on the mounting arm interface with those in the flat bezel panel PC (**Figure 3-31**).

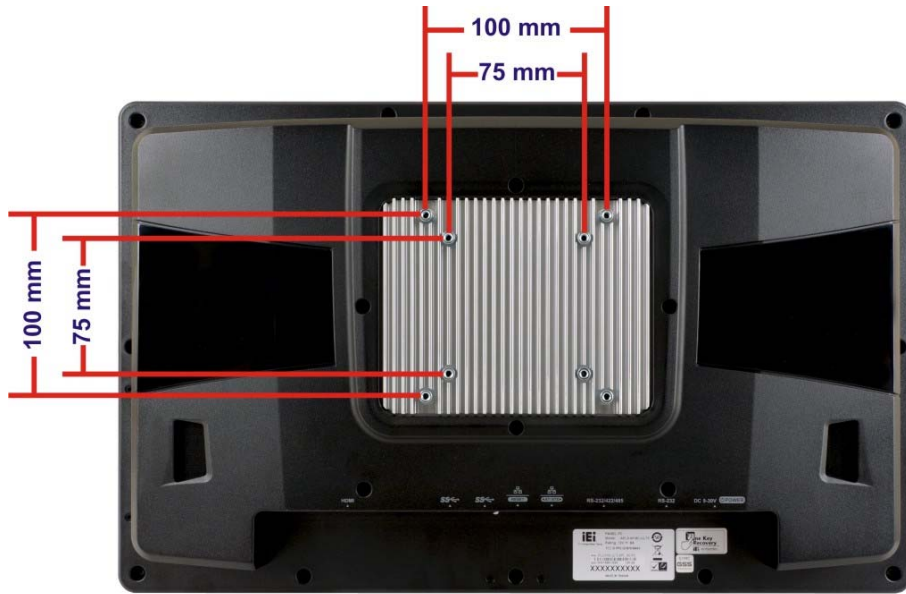

Figure 3-31: Arm Mounting Retention Screw Holes

Step 4: Secure the AFL3-W15C/W19C-ULT3 to the interface pad by inserting four retention screws through the mounting arm interface pad and into the AFL3-W15C/W19C-ULT3.

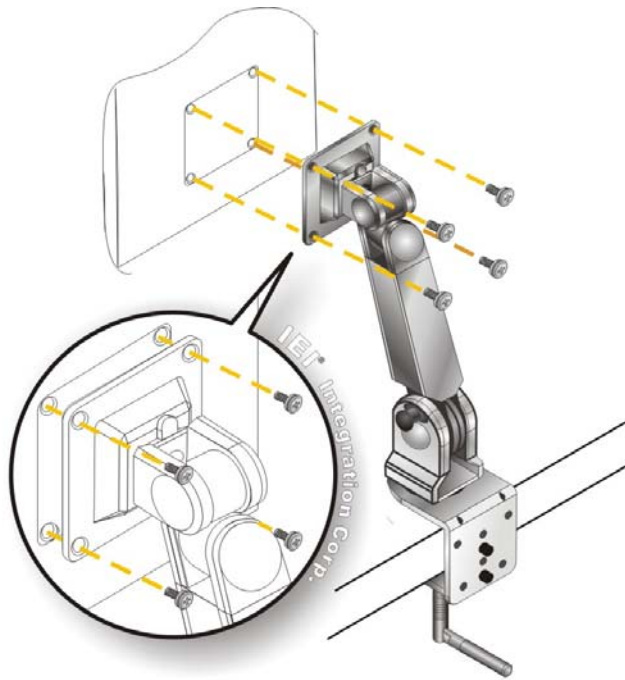

Figure 3-32: Arm Mounting

AFL3-W15C/W19C-ULT3 Panel PC

3.12.5 Stand Mounting

To mount the AFL3-W15C/W19C-ULT3 using the stand mounting kit, please follow the steps below.

- Step 1:** Locate the screw holes on the rear of the AFL3-W15C/W19C-ULT3. This is where the bracket will be attached.
- Step 2:** Align the bracket with the screw holes.
- Step 3:** To secure the bracket to the AFL3-W15C/W19C-ULT3 insert the retention screws into the screw holes and tighten them.

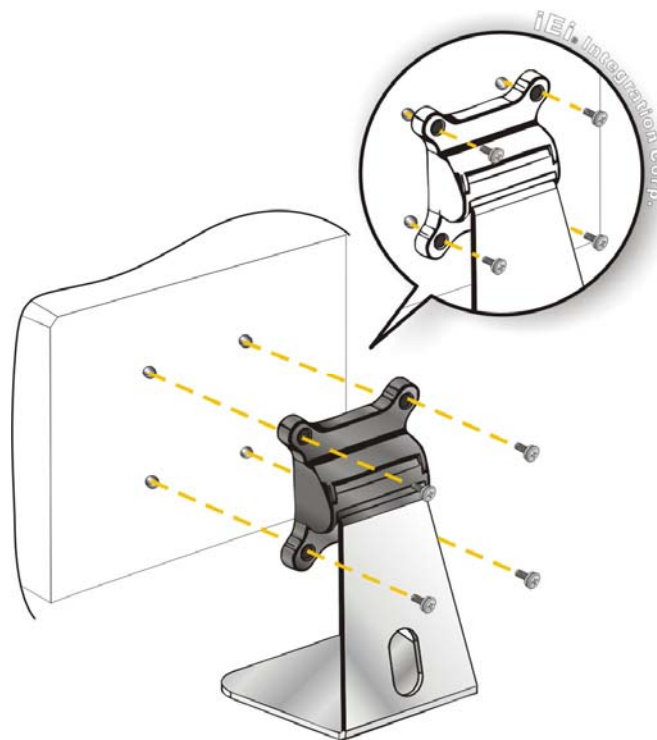

Figure 3-33: Stand Mounting (Stand-A/Bxx)

3.13 Powering On the System

To power on the system, follow the steps below:

- Step 1:** Connect the power cord to the power adapter. Connect the other end of the power cord to a power source.
- Step 2:** Connect the power adapter to the power connector of the AFL3-W15C/W19C-ULT3.
- Step 3:** Locate the power button on the I/O panel.
- Step 4:** Short press the power button to power up the system. Once powered up, the power LED on the front panel turns on in green.



Figure 3-34: Powering On the System

AFL3-W15C/W19C-ULT3 Panel PC

3.14 Reset the System

The reset button enables user to reboot the system when the system is turned on. The reset button location is shown in **Figure 3-35**. Press the reset button to reboot the system.



Figure 3-35: Reset Button Location

3.15 Software Installation



NOTE:

The content of the CD may vary throughout the life cycle of the product and is subject to change without prior notice. Visit the IEI website or contact technical support for the latest updates.

All the drivers for the AFL3-W15C/W19C-ULT3 are on the utility CD that came with the system. The utility CD contains drivers for Windows 7, Windows 8 and Windows 10 operating systems. If the drivers are not installed automatically, please install the following drivers manually.

- Chipset
- VGA (Windows 64-bit OS only)
- LAN (Windows 64-bit OS only)
- Audio
- Intel® Serial IO (Windows 8.1/10 64-bit OS only)
- ME (Intel® AMT)
- USB 3.0 (Windows 7/8.1 OS only)
- Wi-Fi
- Touchscreen

- RFID (for optional RFID module)

3.16 Installing Windows 7 from USB 3.0 Drives

Microsoft Windows 7 installation media does not include native driver support for USB 3.0, so during installation, a keyboard/mouse connected to a USB 3.0 port does not respond. The Windows 7 USB 3.0 Creator Utility automates the steps to update a Windows 7 installation image so that it contains USB 3.0 drivers. To install Windows 7 from a USB drive onto the AFL3-W15C/W19C-ULT3, please follow the steps described below.

- Step 1:** Create a USB flash drive installer. Use your Windows 7 DVD or ISO image to create a bootable USB flash drive. Instructions on how to do are found on [Microsoft's website](#).
- Step 2:** Download and unzip the [Windows 7 USB 3.0 Creator utility](#) to a temporary folder on the Admin system.
- Step 3:** Connect the USB device containing the Windows 7 image to the Admin system.
- Step 4:** Right-click the file "Installer_Creator.exe" and select Run as administrator.
- Step 5:** Browse to the root of the USB drive.
- Step 6:** Click "Create Image" to begin the creation process.
- Step 7:** Wait for the process to finish. It can take up to 15 minutes.
- Step 8:** Using the updated installer, proceed with the Windows 7 installation as you normally would.

Chapter

4

BIOS Setup

4.1 Introduction

The BIOS is programmed onto the BIOS chip. The BIOS setup program allows changes to certain system settings. This chapter outlines the options that can be changed.



NOTE:

Some of the BIOS options may vary throughout the life cycle of the product and are subject to change without prior notice.

4.1.1 Starting Setup

The UEFI BIOS is activated when the computer is turned on. The setup program can be activated in one of two ways.

1. Press the **DELETE** or **F2** key as soon as the system is turned on or
2. Press the **DELETE** or **F2** key when the “**Press Del to enter SETUP**” message appears on the screen.

If the message disappears before the **DELETE** or **F2** key is pressed, restart the computer and try again.

4.1.2 Using Setup

Use the arrow keys to highlight items, press **ENTER** to select, use the PageUp and PageDown keys to change entries, press **F1** for help and press **ESC** to quit. Navigation keys are shown in.

Key	Function
Up arrow	Move to previous item
Down arrow	Move to next item
Left arrow	Move to the item on the left hand side
Right arrow	Move to the item on the right hand side
+	Increase the numeric value or make changes

AFL3-W15C/W19C-ULT3 Panel PC

Key	Function
-	Decrease the numeric value or make changes
F1 key	General help, only for Status Page Setup Menu and Option Page Setup Menu
F2 key	Load previous values.
F3 key	Load optimized defaults
F4 key	Save changes and Exit BIOS
Esc key	Main Menu – Quit and not save changes into CMOS Status Page Setup Menu and Option Page Setup Menu -- Exit current page and return to Main Menu

4.1.3 Getting Help

When **F1** is pressed a small help window describing the appropriate keys to use and the possible selections for the highlighted item appears. To exit the Help Window press **Esc** or the **F1** key again.

4.1.4 Unable to Reboot after Configuration Changes

If the computer cannot boot after changes to the system configuration is made, CMOS defaults. Use the jumper described in **Section 3.10**.

4.1.5 BIOS Menu Bar

The **menu bar** on top of the BIOS screen has the following main items:

- Main – Changes the basic system configuration.
- Advanced – Changes the advanced system settings.
- Chipset – Changes the chipset settings.
- Security – Sets User and Supervisor Passwords.
- Boot – Changes the system boot configuration.
- Save & Exit – Selects exit options and loads default settings

The following sections completely describe the configuration options found in the menu items at the top of the BIOS screen and listed above.

4.2 Main

The **Main** BIOS menu (**BIOS Menu 1**) appears when the **BIOS Setup** program is entered.

Aptio Setup Utility - Copyright (C) 2016 American Megatrends, Inc.					
Main	Advanced	Chipset	Security	Boot	Save & Exit
BIOS Information					
BIOS Vendor	American Megatrends	Set the Date. Use Tab to switch between Data elements.			
Core Version	5.11				
Compliancy	UEFI 2.4; PI 1.3				
Project Version	B384AT11.ROM				
Build Date and Time	10/17/2016 14:25:34				
Processor Information					
Name	SkyLake				
Brand String	Intel(R) Core(TM) i5-6300U CPU @ 2.40GHz				
Frequency	2300 MHz				
Processor ID	406E3				
Stepping	D0/K0				
Number of Processors	2Core(s) / 4Thread(s)	-----			
Microcode Revision	7C				
GT Info	GT2	←→: Select Screen			
IGFX VBIOS Version	1040	↑ ↓: Select Item			
Memory RC Version	1.9.0.0	EnterSelect			
Total Memory	4096 MB	+/-: Change Opt.			
Memory Frequency	2133 MHz	F1: General Help			
PCH Information			F2: Previous Values		
Name	SKL PCH-LP	F3: Optimized Defaults			
PCH SKU	PCH-LP Mobile (U) Premium SKU	F4: Save & Exit			
Stepping	21/C1	ESC: Exit			
LAN PHY Revision	N/A				
ME FW Version	11.0.0.1202				
ME Firmware SKU	Corporate SKU				
SPI Clock Frequency					
D0FR Support	Unsupported				
Read Status Clock Frequency	17 MHz				
Write Status Clock Frequency	17 MHz				
Fast Read Status Clock Frequency	17 MHz				
System Date	[Fri 01/01/2010]				
System Time	[00:18:35]				
Version 2.17.1255. Copyright (C) 2016 American Megatrends, Inc.					

BIOS Menu 1: Main

The System Overview field also has two user configurable fields:

AFL3-W15C/W19C-ULT3 Panel PC

→ System Date [xx/xx/xx]

Use the **System Date** option to set the system date. Manually enter the day, month and year.

→ System Time [xx:xx:xx]

Use the **System Time** option to set the system time. Manually enter the hours, minutes and seconds.

4.3 Advanced

Use the **Advanced** menu (**BIOS Menu 2**) to configure the CPU and peripheral devices through the following sub-menus:



WARNING!

Setting the wrong values in the sections below may cause the system to malfunction. Make sure that the settings made are compatible with the hardware.

```

Aptio Setup Utility - Copyright (C) 2016 American Megatrends, Inc.
Main  Advanced  Chipset  Security  Boot  Save & Exit
-----
> ACPI Settings                               System ACPI Parameters.
> F81866 Super IO Configuration
> F81866 H/W Monitor
> RTC Wake Settings
> Serial Port Console Redirection
> CPU Configuration
> SATA Configuration
> USB Configuration
> iEi Feature

-----
<=>: Select Screen
↑ ↓: Select Item
Enter>Select
F1  General Help
F2  Previous Values
F3  Optimized Defaults
F4  Save
ESC Exit

Version 2.17.1255. Copyright (C) 2016 American Megatrends, Inc.
    
```

BIOS Menu 2: Advanced

4.3.1 ACPI Settings

The **ACPI Settings** menu (**BIOS Menu 3**) configures the Advanced Configuration and Power Interface (ACPI) options.

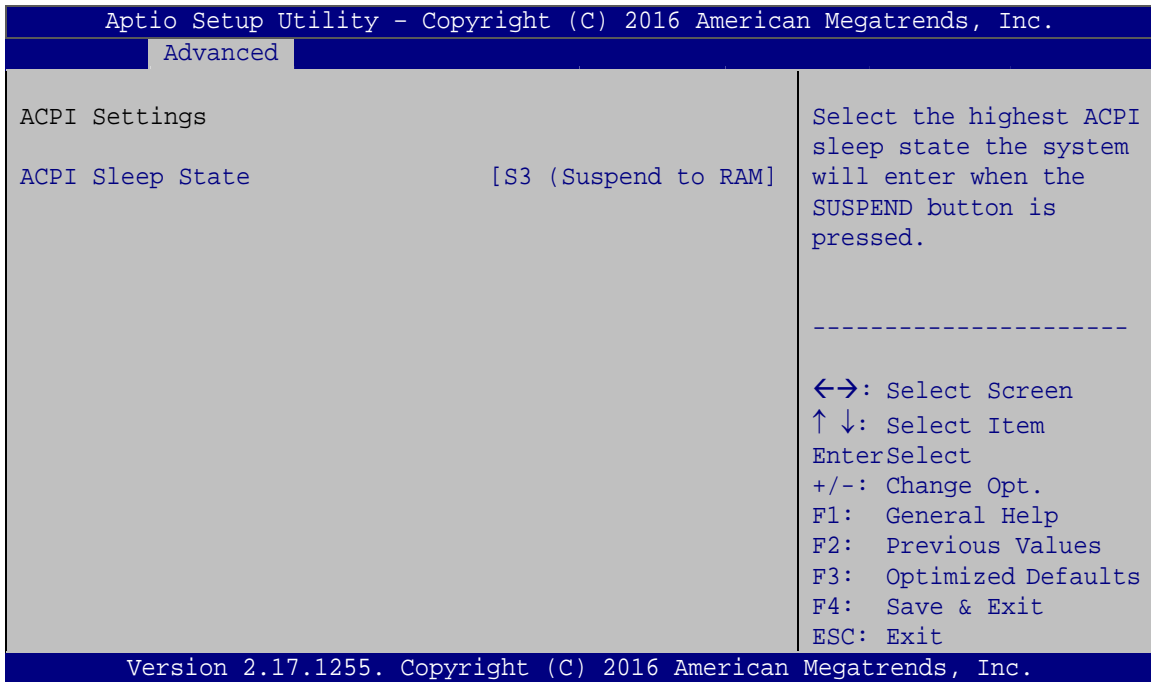

BIOS Menu 3: ACPI Settings

→ **ACPI Sleep State [S3 (Suspend to RAM)]**

Use the **ACPI Sleep State** option to specify the sleep state the system enters when it is not being used.

- **S3 (Suspend to RAM)** **DEFAULT** The caches are flushed and the CPU is powered off. Power to the RAM is maintained. The computer returns slower to a working state, but more power is saved.

AFL3-W15C/W19C-ULT3 Panel PC

4.3.2 F81866 Super IO Configuration

Use the **F81866 Super IO Configuration** menu (**BIOS Menu 4**) to set or change the configurations for the serial ports.

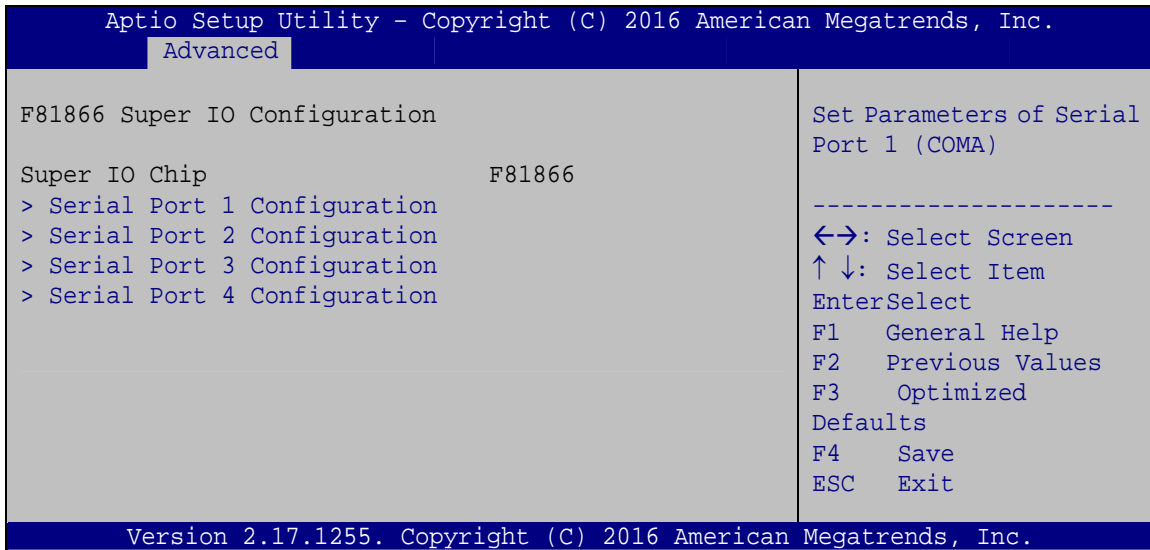

BIOS Menu 4: F81866 Super IO Configuration

4.3.2.1 Serial Port n Configuration

Use the **Serial Port n Configuration** menu (**BIOS Menu 5**) to configure the serial port n.

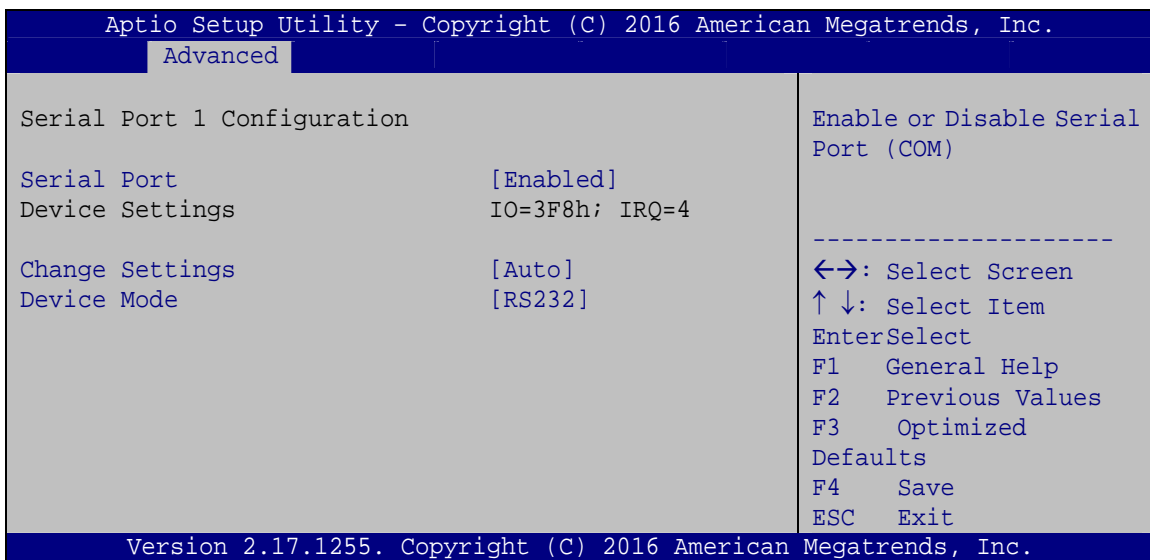

BIOS Menu 5: Serial Port n Configuration

4.3.2.1.1 Serial Port 1 Configuration

➔ **Serial Port [Enabled]**

Use the **Serial Port** option to enable or disable the serial port.

- ➔ **Disabled** Disable the serial port
- ➔ **Enabled** **DEFAULT** Enable the serial port

➔ **Change Settings [Auto]**

Use the **Change Settings** option to change the serial port IO port address and interrupt address.

- ➔ **Auto** **DEFAULT** The serial port IO port address and interrupt address are automatically detected.
- ➔ **IO=3F8h; IRQ=4** Serial Port I/O port address is 3F8h and the interrupt address is IRQ4
- ➔ **IO=3F8h; IRQ=3, 4,5,6,7,9,10,11,12** Serial Port I/O port address is 3F8h and the interrupt address is IRQ3,4,5,6,7,9,10,11,12
- ➔ **IO=2F8h; IRQ=3, 4,5,6,7,9,10,11,12** Serial Port I/O port address is 2F8h and the interrupt address is IRQ3,4,5,6,7,9,10,11,12
- ➔ **IO=3E8h; IRQ=3, 4,5,6,7,9,10,11,12** Serial Port I/O port address is 3E8h and the interrupt address is IRQ3,4,5,6,7,9,10,11,12
- ➔ **IO=2E8h; IRQ=3, 4,5,6,7,9,10,11,12** Serial Port I/O port address is 2E8h and the interrupt address is IRQ3,4,5,6,7,9,10,11,12

AFL3-W15C/W19C-ULT3 Panel PC

→ Device Mode [RS232]

Use the **Device Mode** option to select the Serial Port 3 signaling mode.

- **RS422** Serial Port 3 signaling mode is RS-422
- **RS232** **DEFAULT** Serial Port 3 signaling mode is RS-232
- **RS485** Serial Port 3 signaling mode is RS-485

4.3.2.1.2 Serial Port 2 Configuration

→ Serial Port [Enabled]

Use the **Serial Port** option to enable or disable the serial port.

- **Disabled** Disable the serial port
- **Enabled** **DEFAULT** Enable the serial port

→ Change Settings [Auto]

Use the **Change Settings** option to change the serial port IO port address and interrupt address.

- **Auto** **DEFAULT** The serial port IO port address and interrupt address are automatically detected.
- **IO=2F8h; IRQ=3** Serial Port I/O port address is 2F8h and the interrupt address is IRQ3
- **IO=3F8h; IRQ=3, 4,5,6,7,9,10,11,12** Serial Port I/O port address is 3F8h and the interrupt address is IRQ3,4,5,6,7,9,10,11,12
- **IO=2F8h; IRQ=3, 4,5,6,7,9,10,11,12** Serial Port I/O port address is 2F8h and the interrupt address is IRQ3,4,5,6,7,9,10,11,12
- **IO=3E8h; IRQ=3, 4,5,6,7,9,10,11,12** Serial Port I/O port address is 3E8h and the interrupt address is IRQ3,4,5,6,7,9,10,11,12
- **IO=2E8h; IRQ=3, 4,5,6,7,9,10,11,12** Serial Port I/O port address is 2E8h and the interrupt address is IRQ3,4,5,6,7,9,10,11,12

4.3.2.1.3 Serial Port 3 Configuration

→ **Serial Port [Enabled]**

Use the **Serial Port** option to enable or disable the serial port.

- **Disabled** Disable the serial port
- **Enabled** **DEFAULT** Enable the serial port

→ **Change Settings [Auto]**

Use the **Change Settings** option to change the serial port IO port address and interrupt address.

- **Auto** **DEFAULT** The serial port IO port address and interrupt address are automatically detected.
- **IO=3E8h; IRQ=11** Serial Port I/O port address is 3E8h and the interrupt address is IRQ11
- **IO=3E8h; IRQ=3, 4,5,6,7,9,10,11,12** Serial Port I/O port address is 3E8h and the interrupt address is IRQ3,4,5,6,7,9,10,11,12
- **IO=2E8h; IRQ=3, 4,5,6,7,9,10,11,12** Serial Port I/O port address is 2E8h and the interrupt address is IRQ3,4,5,6,7,9,10,11,12
- **IO=2F0h; IRQ=3, 4,5,6,7,9,10,11,12** Serial Port I/O port address is 2F0h and the interrupt address is IRQ3,4,5,6,7,9,10,11,12
- **IO=2E0h; IRQ=3, 4,5,6,7,9,10,11,12** Serial Port I/O port address is 2E0h and the interrupt address is IRQ3,4,5,6,7,9,10,11,12

AFL3-W15C/W19C-ULT3 Panel PC

4.3.2.1.4 Serial Port 4 Configuration

→ Serial Port [Enabled]

Use the **Serial Port** option to enable or disable the serial port.

- | | | |
|------------|---------|-------------------------|
| → Disabled | | Disable the serial port |
| → Enabled | DEFAULT | Enable the serial port |

→ Change Settings [Auto]

Use the **Change Settings** option to change the serial port IO port address and interrupt address.

- | | | |
|--------------------------------------|---------|---|
| → Auto | DEFAULT | The serial port IO port address and interrupt address are automatically detected. |
| → IO=2E8h; IRQ=11 | | Serial Port I/O port address is 2E8h and the interrupt address is IRQ11 |
| → IO=3E8h; IRQ=3, 4,5,6,7,9,10,11,12 | | Serial Port I/O port address is 3E8h and the interrupt address is IRQ3,4,5,6,7,9,10,11,12 |
| → IO=2E8h; IRQ=3, 4,5,6,7,9,10,11,12 | | Serial Port I/O port address is 2E8h and the interrupt address is IRQ3,4,5,6,7,9,10,11,12 |
| → IO=2F0h; IRQ=3, 4,5,6,7,9,10,11,12 | | Serial Port I/O port address is 2F0h and the interrupt address is IRQ3,4,5,6,7,9,10,11,12 |
| → IO=2E0h; IRQ=3, 4,5,6,7,9,10,11,12 | | Serial Port I/O port address is 2E0h and the interrupt address is IRQ3,4,5,6,7,9,10,11,12 |

4.3.3 F81866 H/W Monitor

The **F81866 H/W Monitor** menu (**BIOS Menu 6**) contains the fan configuration submenus and displays operating temperature, fan speeds and system voltages.

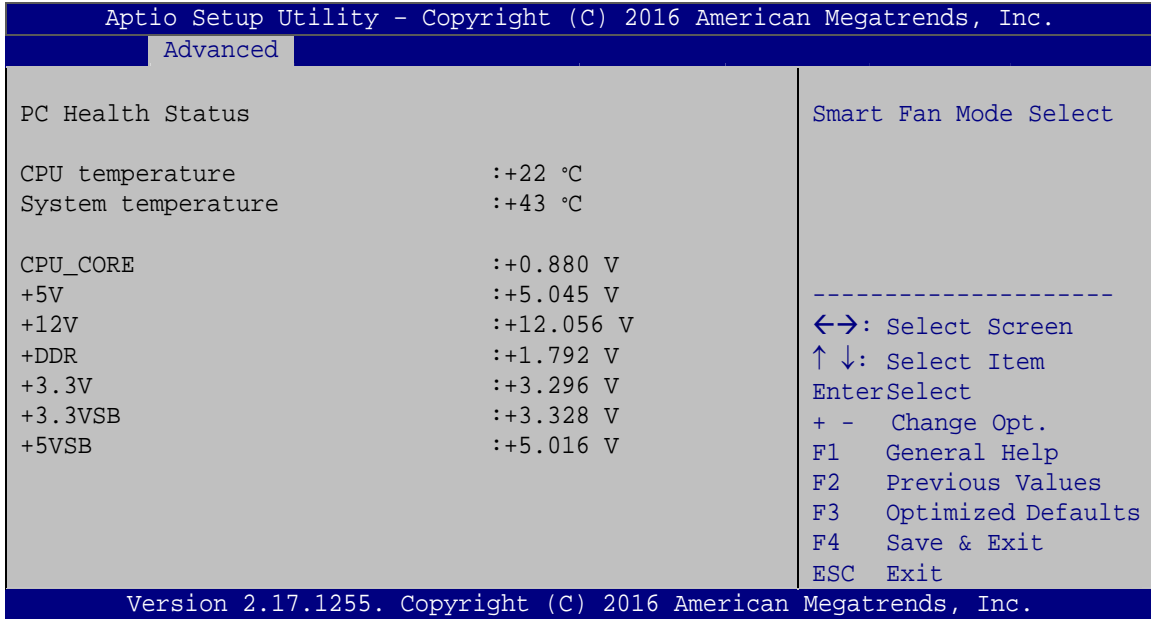

BIOS Menu 6: F81866 H/W Monitor

→ PC Health Status

The following system parameters and values are shown. The system parameters that are monitored are:

- System Temperatures:
 - CPU Temperature
 - System temperature
- Voltages
 - CPU_CORE
 - +5V
 - +12V
 - +DDR
 - +3.3V
 - +3.3VSB
 - +5VSB

AFL3-W15C/W19C-ULT3 Panel PC

4.3.4 RTC Wake Settings

The **RTC Wake Settings** menu (**BIOS Menu 7**) configures RTC wake event.

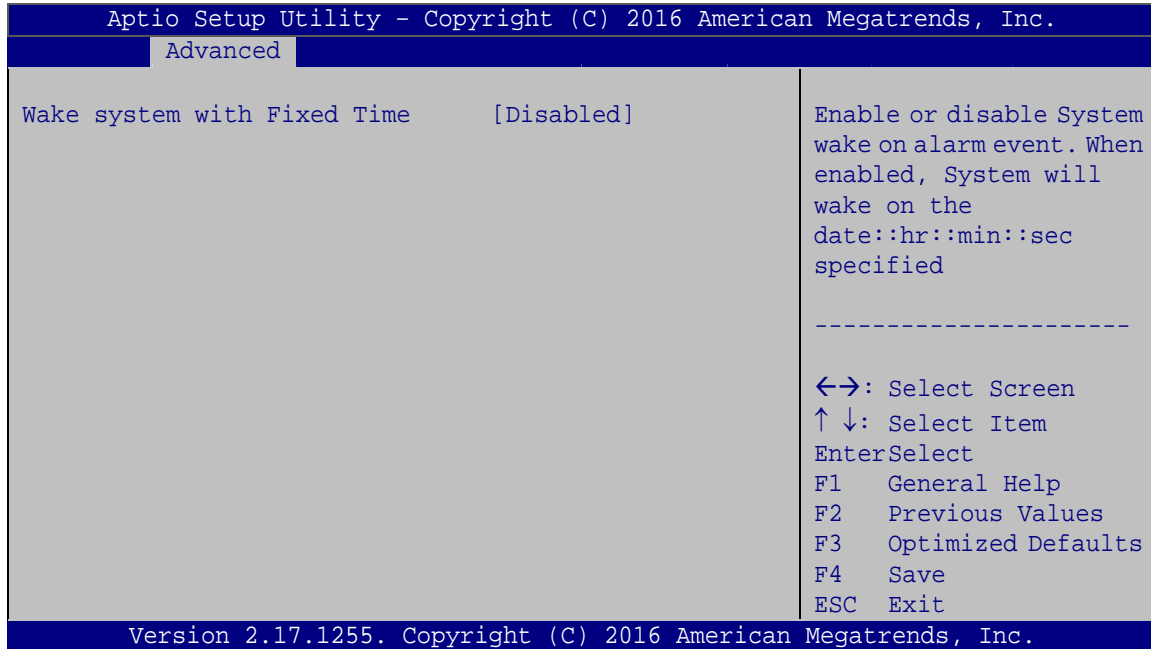

BIOS Menu 7: RTC Wake Settings

→ Wake system with Fixed Time [Disabled]

Use the **Wake system with Fixed Time** option to enable or disable the system wake on alarm event.

→ **Disabled** **DEFAULT** The real time clock (RTC) cannot generate a wake event

→ **Enabled** If selected, the **Wake up every day** option appears allowing you to enable to disable the system to wake every day at the specified time. Besides, the following options appear with values that can be selected:

Wake up date

Wake up hour

Wake up minute

Wake up second

After setting the alarm, the computer turns itself on from a suspend state when the alarm goes off.

4.3.5 Serial Port Console Redirection

The **Serial Port Console Redirection** menu (**BIOS Menu 8**) allows the console redirection options to be configured. Console redirection allows users to maintain a system remotely by re-directing keyboard input and text output through the serial port.

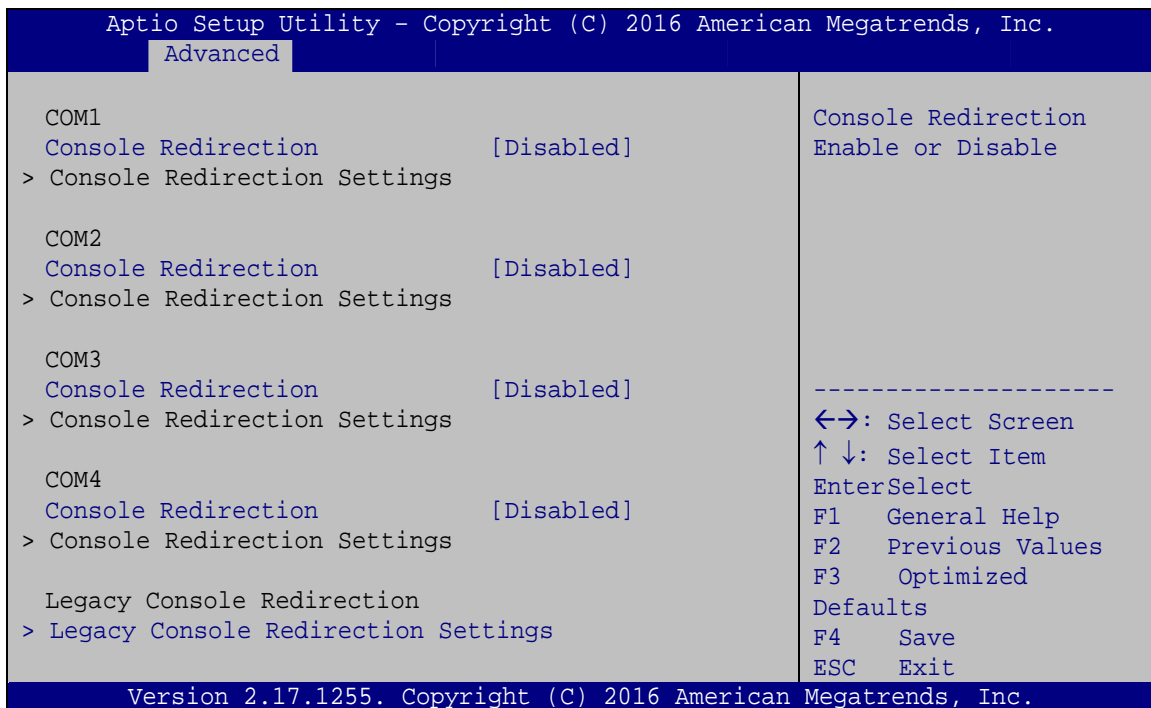

BIOS Menu 8: Serial Port Console Redirection

→ Console Redirection [Disabled]

Use **Console Redirection** option to enable or disable the console redirection function.

- **Disabled** **DEFAULT** Disabled the console redirection function
- **Enabled** Enabled the console redirection function

AFL3-W15C/W19C-ULT3 Panel PC

4.3.5.1 Legacy Console Redirection Settings

The **Legacy Console Redirection Settings** menu (**BIOS Menu 9**) allows the legacy console redirection options to be configured.

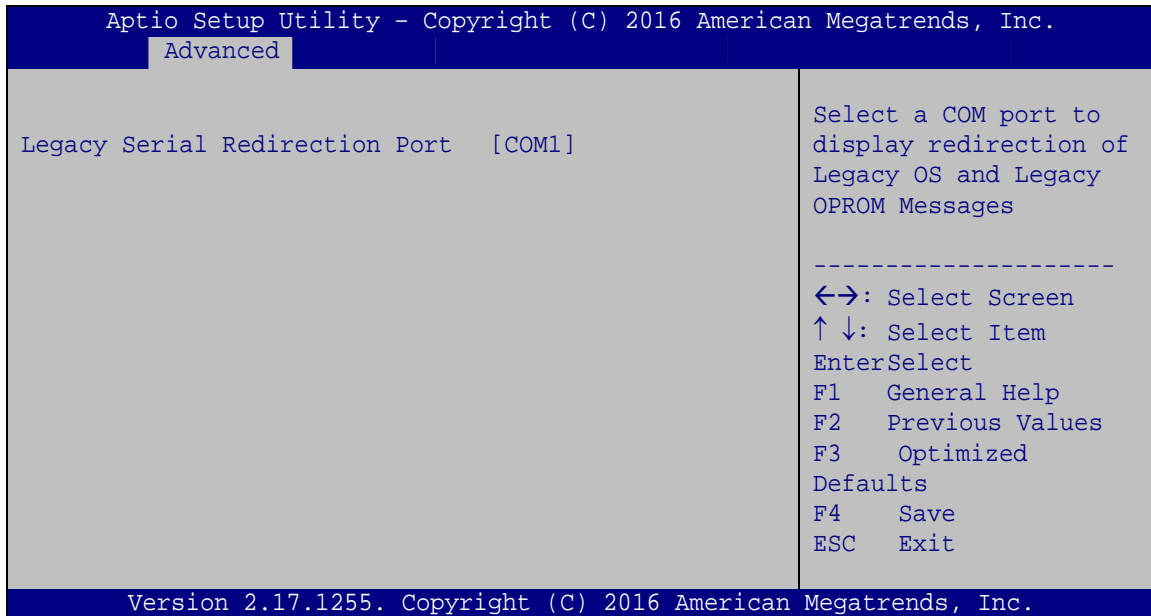

BIOS Menu 9: Legacy Console Redirection Settings

→ Legacy Serial Redirection Port [COM1]

Use the **Legacy Serial Redirection Port** option to specify a COM port to display redirection of legacy OS and legacy OPROM messages. The options include:

- COM1 **DEFAULT**
- COM2
- COM3
- COM4
- COM5 (Pci Bus0, Dev0, Func0) (Disabled)

4.3.5.2 Console Redirection Settings

The **Console Redirection Settings** menu (**BIOS Menu 10**) allows the console redirection options to be configured. The option is active when Console Redirection option is enabled.

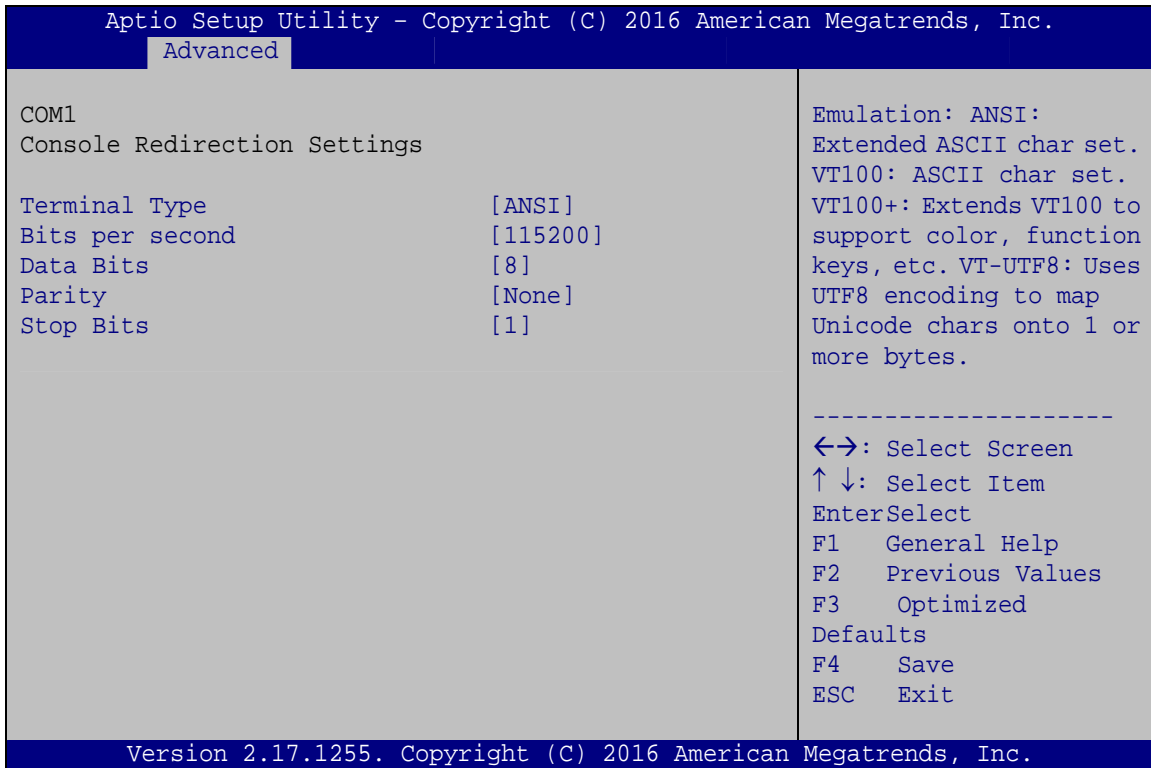

BIOS Menu 10: Console Redirection Settings

➔ Terminal Type [ANSI]

Use the **Terminal Type** option to specify the remote terminal type.

- ➔ **VT100** The target terminal type is VT100
- ➔ **VT100+** The target terminal type is VT100+
- ➔ **VT-UTF8** The target terminal type is VT-UTF8
- ➔ **ANSI** **DEFAULT** The target terminal type is ANSI

AFL3-W15C/W19C-ULT3 Panel PC

→ Bits per second [115200]

Use the **Bits per second** option to specify the serial port transmission speed. The speed must match the other side. Long or noisy lines may require lower speeds.

- | | | | |
|---|---------------|----------------|--|
| → | 9600 | | Sets the serial port transmission speed at 9600. |
| → | 19200 | | Sets the serial port transmission speed at 19200. |
| → | 57600 | | Sets the serial port transmission speed at 57600. |
| → | 115200 | DEFAULT | Sets the serial port transmission speed at 115200. |

→ Data Bits [8]

Use the **Data Bits** option to specify the number of data bits.

- | | | | |
|---|----------|----------------|--------------------------|
| → | 7 | | Sets the data bits at 7. |
| → | 8 | DEFAULT | Sets the data bits at 8. |

→ Parity [None]

Use the **Parity** option to specify the parity bit that can be sent with the data bits for detecting the transmission errors.

- | | | | |
|---|--------------|----------------|---|
| → | None | DEFAULT | No parity bit is sent with the data bits. |
| → | Even | | The parity bit is 0 if the number of ones in the data bits is even. |
| → | Odd | | The parity bit is 0 if the number of ones in the data bits is odd. |
| → | Mark | | The parity bit is always 1. This option does not provide error detection. |
| → | Space | | The parity bit is always 0. This option does not provide error detection. |

→ **Stop Bits [1]**

Use the **Stop Bits** option to specify the number of stop bits used to indicate the end of a serial data packet. Communication with slow devices may require more than 1 stop bit.

- 1 **DEFAULT** Sets the number of stop bits at 1.
- 2 Sets the number of stop bits at 2.

4.3.6 CPU Configuration

Use the **CPU Configuration** menu (**BIOS Menu 11**) to view detailed CPU specifications and configure the CPU.

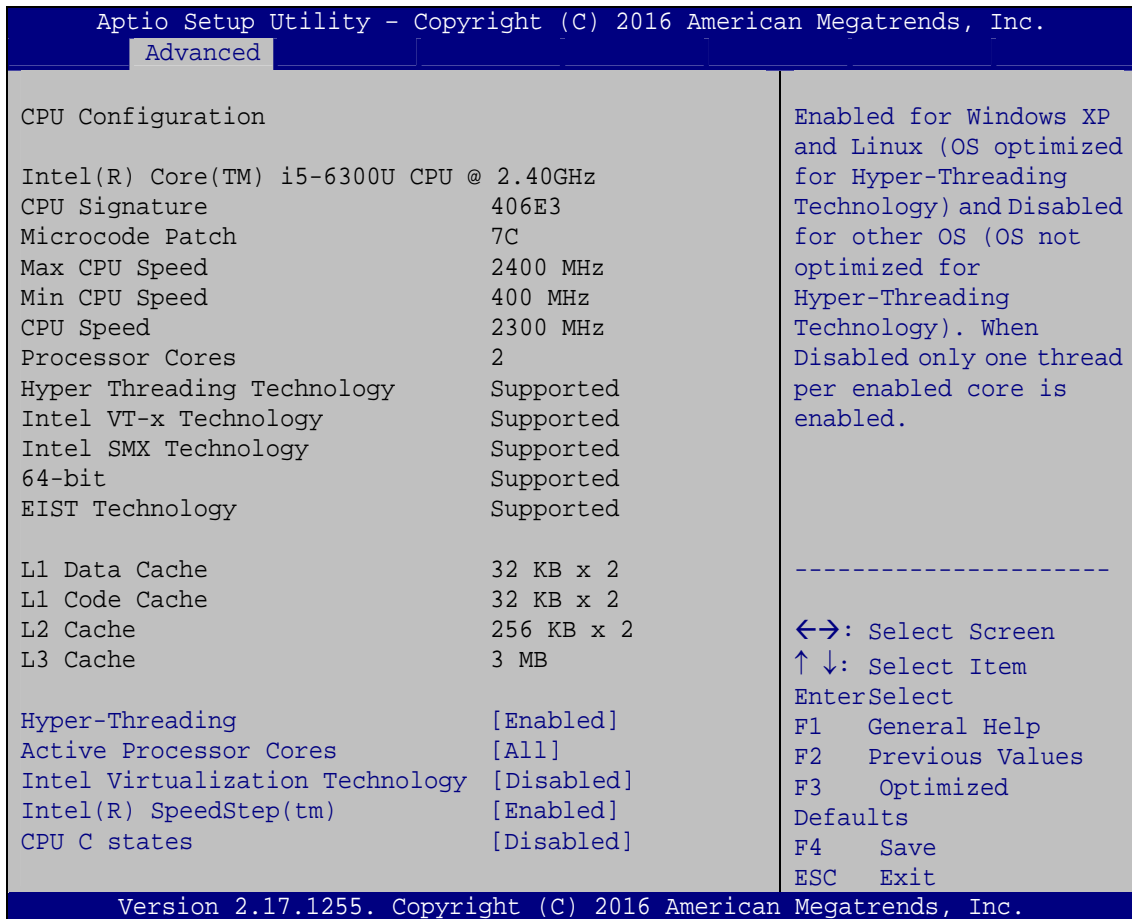

Aptio Setup Utility - Copyright (C) 2016 American Megatrends, Inc.

Advanced

CPU Configuration		Enabled for Windows XP and Linux (OS optimized for Hyper-Threading Technology) and Disabled for other OS (OS not optimized for Hyper-Threading Technology). When Disabled only one thread per enabled core is enabled.
Intel(R) Core(TM) i5-6300U CPU @ 2.40GHz		
CPU Signature	406E3	
Microcode Patch	7C	
Max CPU Speed	2400 MHz	
Min CPU Speed	400 MHz	
CPU Speed	2300 MHz	
Processor Cores	2	
Hyper Threading Technology	Supported	
Intel VT-x Technology	Supported	
Intel SMX Technology	Supported	
64-bit	Supported	
EIST Technology	Supported	

L1 Data Cache	32 KB x 2	
L1 Code Cache	32 KB x 2	
L2 Cache	256 KB x 2	
L3 Cache	3 MB	
Hyper-Threading	[Enabled]	
Active Processor Cores	[All]	
Intel Virtualization Technology	[Disabled]	
Intel(R) SpeedStep(tm)	[Enabled]	
CPU C states	[Disabled]	

←→: Select Screen
↑ ↓: Select Item
Enter>Select
F1 General Help
F2 Previous Values
F3 Optimized
Defaults
F4 Save
ESC Exit

Version 2.17.1255. Copyright (C) 2016 American Megatrends, Inc.

BIOS Menu 11: CPU Configuration

AFL3-W15C/W19C-ULT3 Panel PC

→ Hyper Threading Function [Enabled]

Use the Hyper Threading function to enable or disable the CPU hyper threading function.

- **Disabled** Disables the use of hyper threading technology
- **Enabled** **DEFAULT** Enables the use of hyper threading technology

→ Active Processor Cores [All]

Use the **Active Processor Cores** BIOS option to enable numbers of cores in the processor package.

- **All** **DEFAULT** Enable all cores in the processor package.
- **1** Enable one core in the processor package.

→ Intel® Virtualization Technology [Disabled]

Use the **Intel® Virtualization Technology** option to enable or disable virtualization on the system. When combined with third party software, Intel® Virtualization technology allows several OSs to run on the same system at the same time.

- **Disabled** **DEFAULT** Disables Intel® Virtualization Technology.
- **Enabled** Enables Intel® Virtualization Technology.

→ Intel® SpeedStep™ [Enabled]

Use the **Intel® SpeedStep™** option to enable or disable the Intel® SpeedStep Technology.

- **Disabled** Disables the Intel® SpeedStep Technology.
- **Enabled** **DEFAULT** Enables the Intel® SpeedStep Technology.

➔ **CPU C State [Disabled]**

Use the **CPU C State** option to enable or disable CPU C state.

- ➔ **Disabled** **DEFAULT** Disables CPU C state.
- ➔ **Enabled** Enables CPU C state.

4.3.7 SATA Configuration

Use the **SATA Configuration** menu (**BIOS Menu 12**) to change and/or set the configuration of the SATA devices installed in the system.

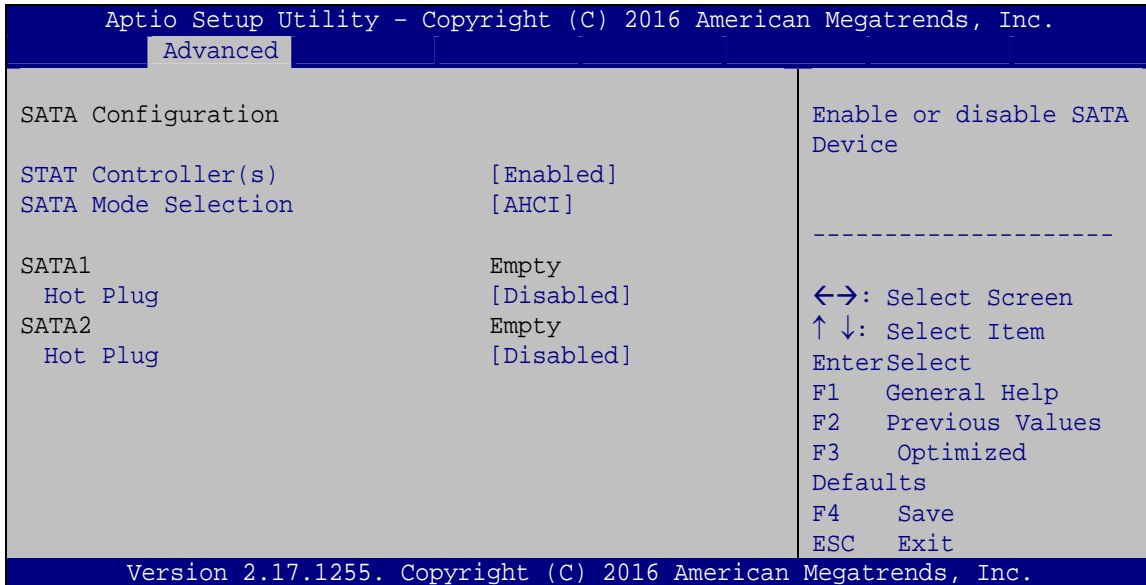

BIOS Menu 12: SATA Configuration

➔ **STAT Controller(s) [Enabled]**

Use the **STAT Controller(s)** option to enable or disable the SATA device.

- ➔ **Enabled** **DEFAULT** Enables the SATA device.
- ➔ **Disabled** Disables the SATA device.

AFL3-W15C/W19C-ULT3 Panel PC

→ SATA Mode Selection [AHCI]

Use the **SATA Mode Selection** option to configure SATA devices as AHCI devices.

- **AHCI** **DEFAULT** Configures SATA devices as AHCI device.
- **RAID** Configures SATA devices as RAID device.



NOTE:

Before accessing the RAID configuration utility, ensure to set the **Option ROM Messages** BIOS option in the **Boot** menu to **Force BIOS**. This is to allow the “Press <CTRL+I> to enter Configuration Utility.....” message to appear during POST. Press Ctrl+I when prompted to enter the RAID configuration utility.

→ Hot Plug [Disabled]

Use the **Hot Plug** option to enable or disable the SATA device hot plug.

- **Disabled** **DEFAULT** Disables the SATA device hot plug.
- **Enabled** Enables the SATA device hot plug

4.3.8 USB Configuration

Use the **USB Configuration** menu (**BIOS Menu 13**) to read USB configuration information and configure the USB settings.

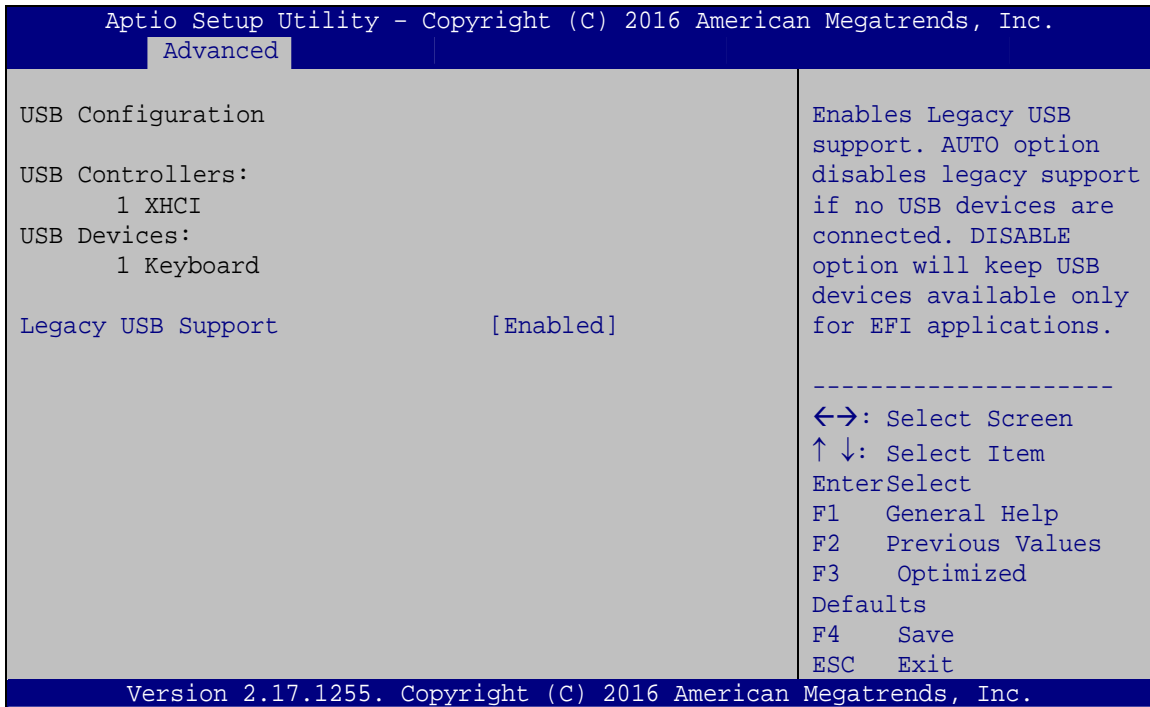

BIOS Menu 13: USB Configuration

➔ **USB Devices**

The **USB Devices Enabled** field lists the USB devices that are enabled on the system

➔ **Legacy USB Support [Enabled]**

Use the **Legacy USB Support** BIOS option to enable USB mouse and USB keyboard support. Normally if this option is not enabled, any attached USB mouse or USB keyboard does not become available until a USB compatible operating system is fully booted with all USB drivers loaded. When this option is enabled, any attached USB mouse or USB keyboard can control the system even when there is no USB driver loaded onto the system.

AFL3-W15C/W19C-ULT3 Panel PC

- ➔ **Enabled** **DEFAULT** Legacy USB support enabled
- ➔ **Disabled** Legacy USB support disabled
- ➔ **Auto** Legacy USB support disabled if no USB devices are connected

4.3.9 IEI Feature

Use the **IEI Feature** menu (**BIOS Menu 14**) to configure One Key Recovery function.

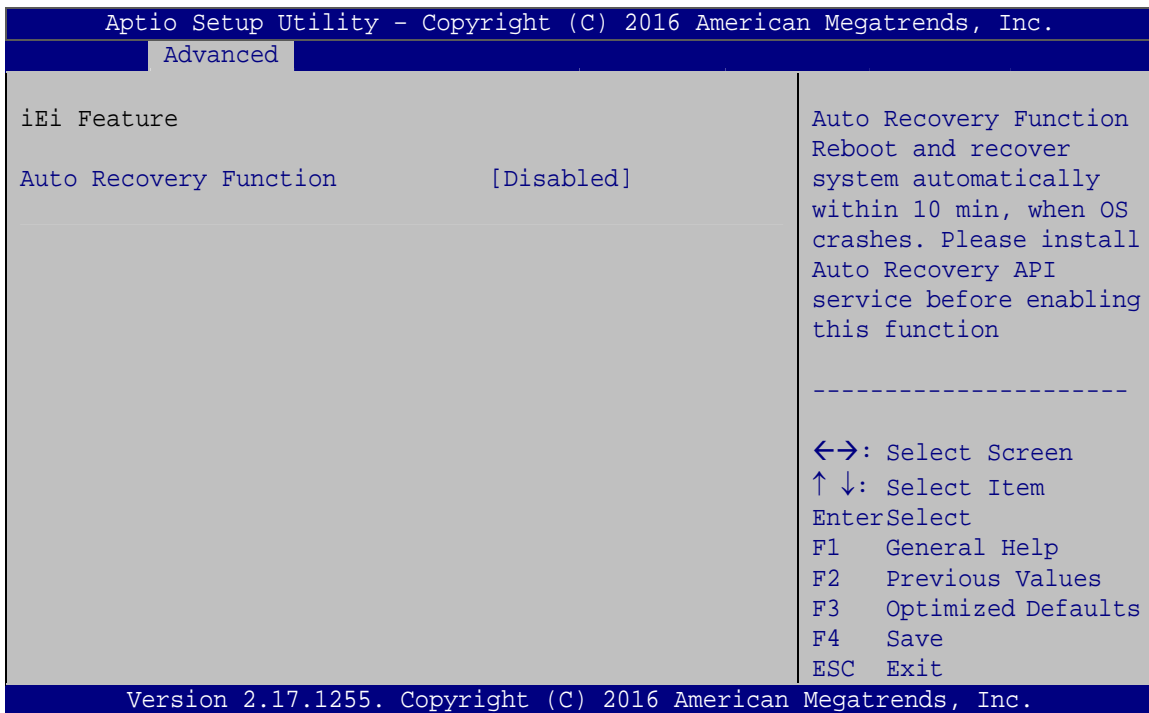

BIOS Menu 14: IEI Feature

➔ **Auto Recovery Function [Disabled]**

Use the **Auto Recovery Function** BIOS option to enable or disable the auto recovery function of the IEI One Key Recovery.

- ➔ **Disabled** **DEFAULT** Auto recovery function disabled
- ➔ **Enabled** Auto recovery function enabled

4.4 Chipset

Use the **Chipset** menu (**BIOS Menu 15**) to configure the system chipset.

```

Aptio Setup Utility - Copyright (C) 2016 American Megatrends, Inc.
Main   Advanced  Chipset  Security  Boot   Save & Exit
-----
> System Agent (SA) Configuration
> PCH-IO Configuration

System Agent (SA)
Parameters

-----
<-->: Select Screen
↑ ↓: Select Item
Enter>Select
+ -  Change Opt.
F1   General Help
F2   Previous Values
F3   Optimized Defaults
F4   Save & Exit
ESC  Exit

Version 2.17.1255. Copyright (C) 2016 American Megatrends, Inc.
    
```

BIOS Menu 15: Chipset

4.4.1 System Agent (SA) Configuration

Use the **System Agent (SA) Configuration** menu (**BIOS Menu 16**) to configure the System Agent (SA) parameters.

```

Aptio Setup Utility - Copyright (C) 2016 American Megatrends, Inc.
-----
Chipset

VT-d                               [Disabled]          VT-d capability

> Graphics Configuration
> Memory Configuration

-----
<-->: Select Screen
↑ ↓: Select Item
Enter>Select
+ -  Change Opt.
F1   General Help
F2   Previous Values
F3   Optimized Defaults
F4   Save & Exit
ESC  Exit

Version 2.17.1255. Copyright (C) 2016 American Megatrends, Inc.
    
```

BIOS Menu 16: System Agent (SA) Configuration

AFL3-W15C/W19C-ULT3 Panel PC

→ VT-d [Disabled]

Use the **VT-d** option to enable or disable VT-d support.

- **Disabled** **DEFAULT** Disable VT-d support.
- **Enabled** Enable VT-d support.

4.4.1.1 Graphics Configuration

Use the **Graphics Configuration** menu (**BIOS Menu 17**) to configure the graphics settings.

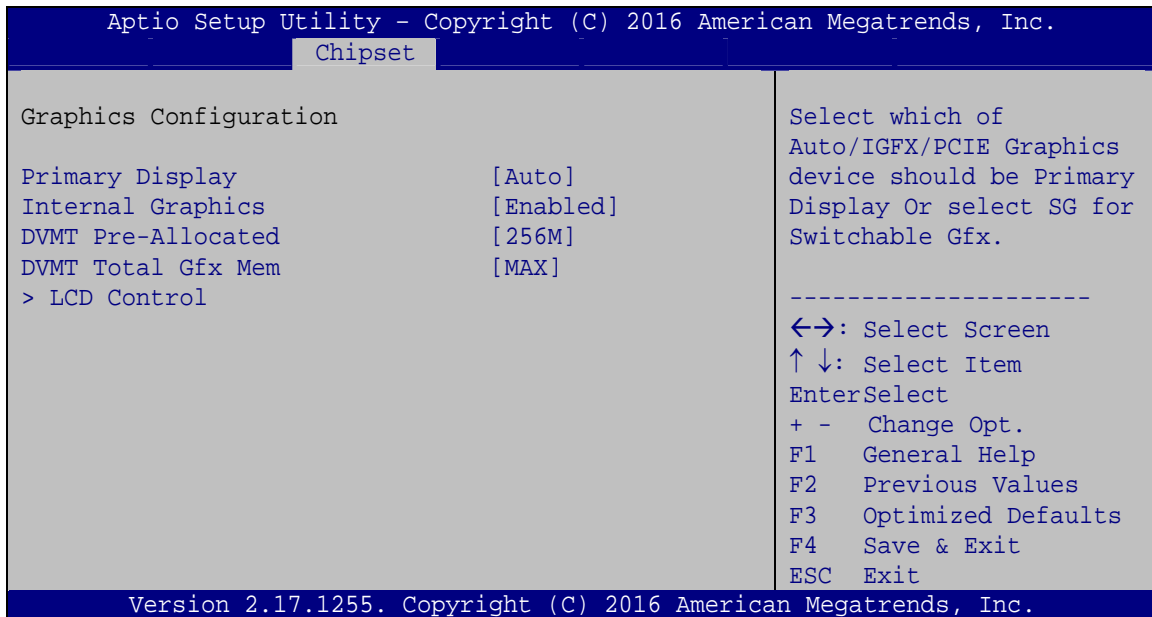

BIOS Menu 17: Graphics Configuration

→ Primary Display [Auto]

Use the **Primary Display** option to select the graphics controller used as the primary boot device. Configuration options are listed below:

- **Auto** **DEFAULT**
- **IGFX**
- **PCIE**

→ Internal Graphics [Enabled]

Use the **Internal Graphics** option to enable or disable the internal graphics device.

- Auto** The internal graphics device is automatically detected and enabled.
- Disabled** Disable the internal graphics device.
- Enabled DEFAULT** Enable the internal graphics device. The following options/submenu appear with values that can be selected:

DVMT Pre-Allocated

DVMT Total Gfx Mem

LCD Control

→ DVMT Pre-Allocated [256M]

Use the **DVMT Pre-Allocated** option to set the amount of system memory allocated to the integrated graphics processor when the system boots. The system memory allocated can then only be used as graphics memory, and is no longer available to applications or the operating system. Configuration options are listed below:

- 32M
- 64M
- 128M
- 256M **DEFAULT**
- 512M

→ DVMT Total Gfx Mem [MAX]

Use the **DVMT Total Gfx Mem** option to select DVMT 5.0 total graphic memory size used by the internal graphics device. The following options are available:

- 128M
- 256M
- MAX **DEFAULT**

AFL3-W15C/W19C-ULT3 Panel PC

4.4.1.1.1 LCD Control

Use the **LCD Control** submenu (**BIOS Menu 18**) to select a display device which will be activated during POST.

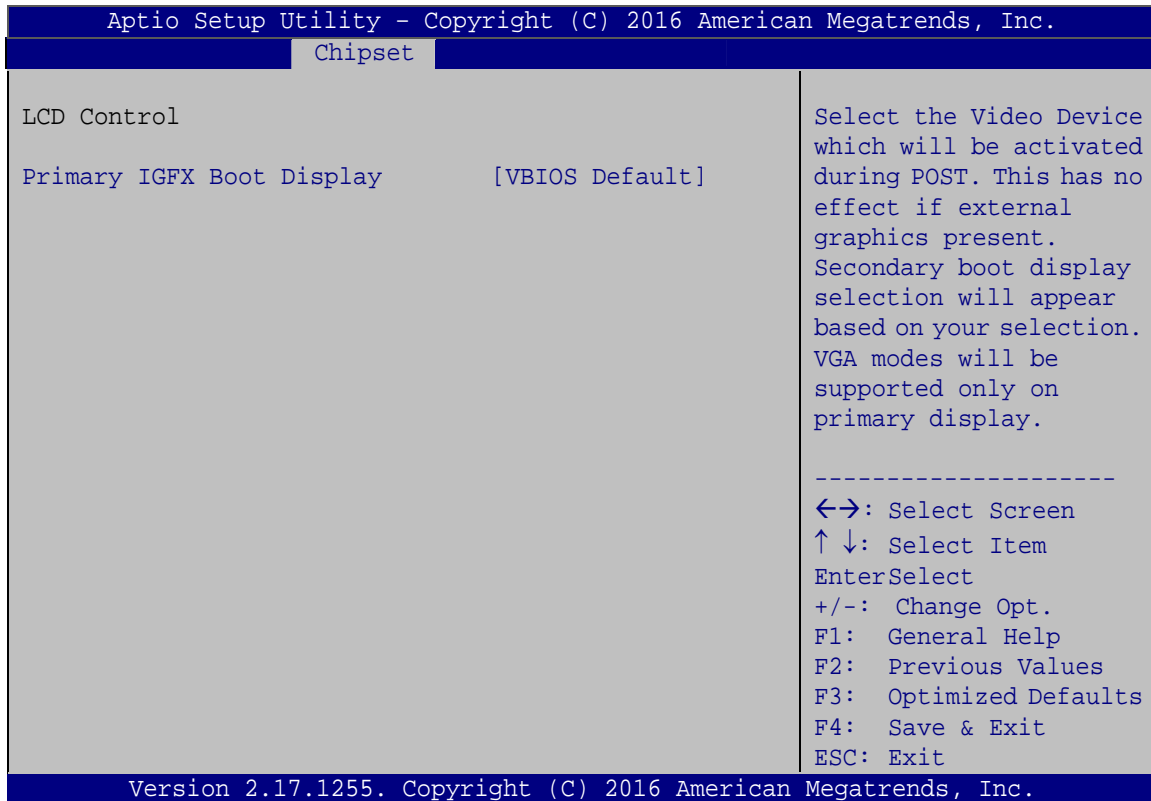

BIOS Menu 18: LCD Control

→ Primary IGFX Boot Display [VBIOS Default]

Use the **Primary IGFX Boot Display** option to select the display device used by the system when it boots.

- VBIOS Default **DEFAULT**
- HDMI1
- LVDS
- DP1

4.4.1.2 Memory Configuration

Use the **Memory Configuration** submenu (**BIOS Menu 19**) to display the memory information.

```

Aptio Setup Utility - Copyright (C) 2016 American Megatrends, Inc.
Chipset
Memory Information
Total Memory          4096 MB
DIMM1                 Not Present
DIMM2                 4096 MB
-----
<->: Select Screen
↑ ↓: Select Item
EnterSelect
+ - Change Opt.
F1  General Help
F2  Previous Values
F3  Optimized Defaults
F4  Save & Exit
ESC Exit

Version 2.17.1255. Copyright (C) 2016 American Megatrends, Inc.
    
```

BIOS Menu 19: Memory Configuration

4.4.2 PCH-IO Configuration

Use the **PCH-IO Configuration** menu (**BIOS Menu 20**) to configure the PCH-IO chipset.

```

Aptio Setup Utility - Copyright (C) 2016 American Megatrends, Inc.
Chipset
Auto Power Button Status [Disable (ATX)]
Restore AC Power Loss    [Last State]
> PCI Express Configuration
> HD Audio Configuration
-----
Select AC power state when
power is re-applied after
a power failure.
-----
<->: Select Screen
↑ ↓: Select Item
EnterSelect
+ - Change Opt.
F1  General Help
F2  Previous Values
F3  Optimized Defaults
F4  Save & Exit
ESC Exit

Version 2.17.1255. Copyright (C) 2016 American Megatrends, Inc.
    
```

BIOS Menu 20: PCH-IO Configuration

AFL3-W15C/W19C-ULT3 Panel PC

→ Restore AC Power Loss [Last State]

Use the **Restore AC Power** BIOS option to specify what state the system returns to if there is a sudden loss of power to the system.

- **Power Off** The system remains turned off
- **Power On** The system turns on
- **Last State** **DEFAULT** The system returns to its previous state. If it was on, it turns itself on. If it was off, it remains off.

4.4.2.1 PCI Express Configuration

Use the **PCI Express Configuration** submenu (**BIOS Menu 21**) to configure the PCI Express slots.

```

Aptio Setup Utility - Copyright (C) 2016 American Megatrends, Inc.
Chipset
-----
PCI Express Configuration
> M2_M_KEY1
> M_PCIE1
> M2_CN1

M_PCIE1 Slot Settings.
-----
<->: Select Screen
↑ ↓: Select Item
Enter>Select
+ - Change Opt.
F1 General Help
F2 Previous Values
F3 Optimized Defaults
F4 Save & Exit
ESC Exit

Version 2.17.1255. Copyright (C) 2016 American Megatrends, Inc.
    
```

BIOS Menu 21: PCI Express Configuration

The PCIe slot submenus all contain the following options:

→ PCIe Speed [Auto]

Use the **PCIe Speed** option to configure the PCIe interface speed.

- Auto **DEFAULT**
- Gen 1

- Gen 2
- Gen 3

➔ **Detect Non-Compliance Device [Disabled]**

Use the **Detect Non-Compliance Device** option to enable or disable detecting if a non-compliance PCI Express device is connected to the PCI Express slot.

- ➔ **Disabled** **DEFAULT** Disables to detect if a non-compliance PCI Express device is connected to the PCI Express slot.
- ➔ **Enabled** Enables to detect if a non-compliance PCI Express device is connected to the PCI Express slot.

4.4.2.2 HD Audio Configuration

Use the **HD Audio Configuration** submenu (**BIOS Menu 22**) to configure the High Definition Audio codec.

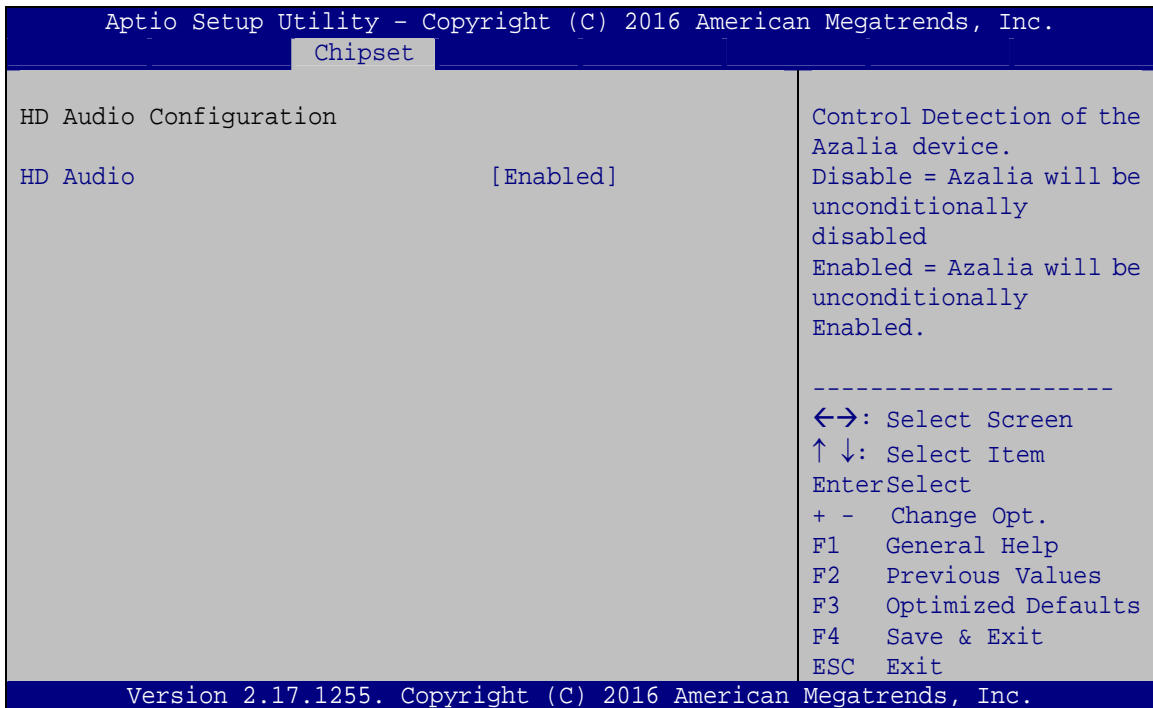

BIOS Menu 22: HD Audio Configuration

AFL3-W15C/W19C-ULT3 Panel PC

→ HD Audio [Enabled]

Use the **HD Audio** BIOS option to enable or disable the High Definition Audio controller.

- **Disabled** The High Definition Audio controller is disabled.
- **Enabled DEFAULT** The High Definition Audio controller is enabled.

4.5 Security

Use the **Security** menu (**BIOS Menu 23**) to set system and user passwords.

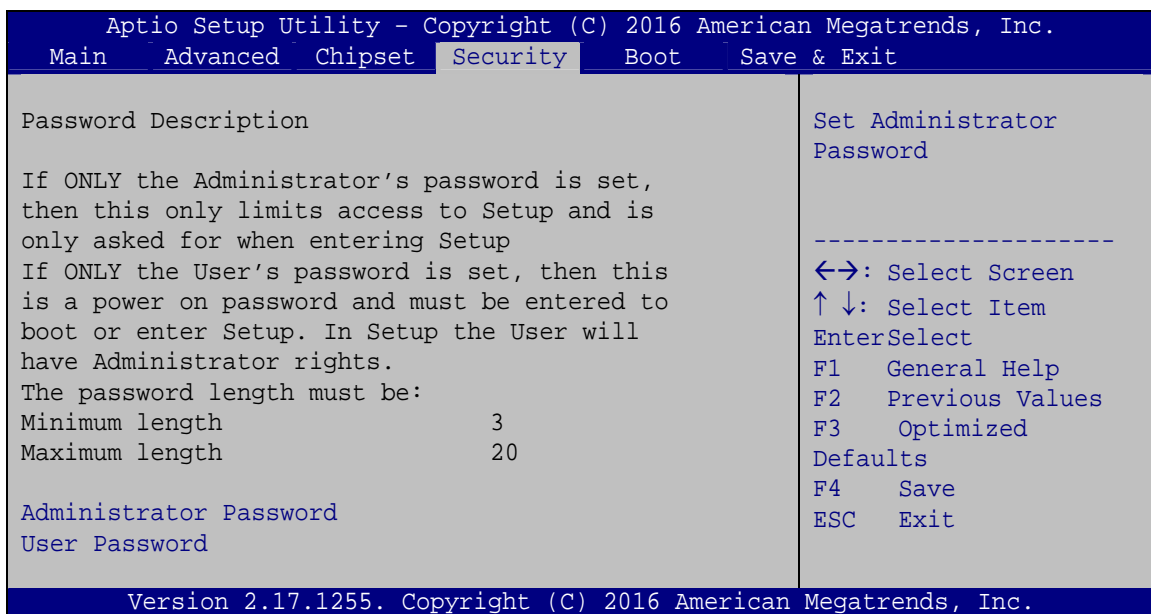

BIOS Menu 23: Security

→ Administrator Password

Use the **Administrator Password** to set or change a administrator password.

→ User Password

Use the **User Password** to set or change a user password.

4.6 Boot

Use the **Boot** menu (**BIOS Menu 24**) to configure system boot options.

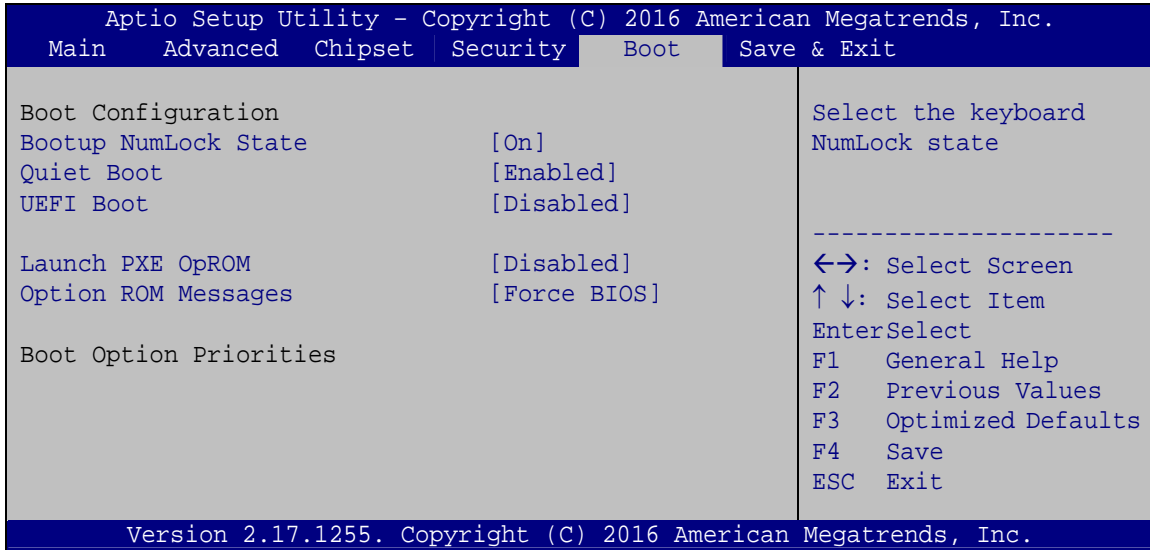

BIOS Menu 24: Boot

→ Bootup NumLock State [On]

Use the **Bootup NumLock State** BIOS option to specify if the number lock setting must be modified during boot up.

- **On** **DEFAULT** Allows the Number Lock on the keyboard to be enabled automatically when the computer system boots up. This allows the immediate use of the 10-key numeric keypad located on the right side of the keyboard. To confirm this, the Number Lock LED light on the keyboard is lit.

- **Off** Does not enable the keyboard Number Lock automatically. To use the 10-keys on the keyboard, press the Number Lock key located on the upper left-hand corner of the 10-key pad. The Number Lock LED on the keyboard lights up when the Number Lock is engaged.

AFL3-W15C/W19C-ULT3 Panel PC

→ Quiet Boot [Enabled]

Use the **Quiet Boot** BIOS option to select the screen display when the system boots.

- **Disabled** Normal POST messages displayed
- **Enabled** **DEFAULT** OEM Logo displayed instead of POST messages

→ UEFI Boot [Disabled]

Use the **UEFI Boot** option to enable or disable to boot from the UEFI devices.

- **Enabled** Boot from UEFI devices is enabled.
- **Disabled** **DEFAULT** Boot from UEFI devices is disabled.

→ Launch PXE OpROM [Disabled]

Use the **Launch PXE OpROM** option to enable or disable boot option for legacy network devices.

- **Disabled** **DEFAULT** Ignore all PXE Option ROMs
- **Enabled** Load PXE Option ROMs.

→ Option ROM Messages [Force BIOS]

Use the **Option ROM Messages** option to set the Option ROM display mode.

- **Force BIOS** **DEFAULT** Sets display mode to force BIOS.
- **Keep Current** Sets display mode to current.

→ Boot Option Priority

Use the **Boot Option Priority** function to set the system boot sequence from the available devices. The drive sequence also depends on the boot sequence in the individual device section.

4.7 Exit

Use the **Exit** menu (**BIOS Menu 25**) to load default BIOS values, optimal failsafe values and to save configuration changes.

```
Aptio Setup Utility - Copyright (C) 2016 American Megatrends, Inc.
Main   Advanced  Chipset  Security  Boot   Save & Exit
-----
Save Changes and Reset
Discard Changes and Reset

Restore Defaults
Save as User Defaults
Restore User Defaults

Reset the system after
saving the changes.

-----
<->: Select Screen
↑ ↓: Select Item
Enter>Select
F1   General Help
F2   Previous Values
F3   Optimized
Defaults
F4   Save
ESC  Exit

Version 2.17.1255. Copyright (C) 2016 American Megatrends, Inc.
```

BIOS Menu 25: Exit

→ Save Changes and Reset

Use the **Save Changes and Reset** option to save the changes made to the BIOS options and to exit the BIOS configuration setup program.

→ Discard Changes and Reset

Use the **Discard Changes and Reset** option to exit the system without saving the changes made to the BIOS configuration setup program.

→ Restore Defaults

Use the **Restore Defaults** option to load the optimal default values for each of the parameters on the Setup menus. **F3 key can be used for this operation.**

AFL3-W15C/W19C-ULT3 Panel PC

→ **Save as User Defaults**

Use the **Save as User Defaults** option to save the changes done so far as user defaults.

→ **Restore User Defaults**

Use the **Restore User Defaults** option to restore the user defaults to all the setup options.

Chapter

5

System Maintenance

AFL3-W15C/W19C-ULT3 Panel PC

5.1 System Maintenance Introduction

If the components of the AFL3-W15C/W19C-ULT3 fail they must be replaced. Please contact the system reseller or vendor to purchase the replacement parts. Back cover removal instructions for the AFL3-W15C/W19C-ULT3 are described below.

5.2 Anti-static Precautions



WARNING:

Failure to take ESD precautions during the maintenance of the AFL3-W15C/W19C-ULT3 may result in permanent damage to the AFL3-W15C/W19C-ULT3 and severe injury to the user.

Electrostatic discharge (ESD) can cause serious damage to electronic components, including the AFL3-W15C/W19C-ULT3. Dry climates are especially susceptible to ESD. It is therefore critical that whenever the AFL3-W15C/W19C-ULT3 is accessed internally, or any other electrical component is handled, the following anti-static precautions are strictly adhered to.

- **Wear an anti-static wristband:** - Wearing a simple anti-static wristband can help to prevent ESD from damaging the board.
- **Self-grounding:** - Before handling the board touch any grounded conducting material. During the time the board is handled, frequently touch any conducting materials that are connected to the ground.
- **Use an anti-static pad:** - When configuring the AFL3-W15C/W19C-ULT3, place it on an anti-static pad. This reduces the possibility of ESD damaging the AFL3-W15C/W19C-ULT3.
- **Only handle the edges of the PCB:** - When handling the PCB, hold the PCB by the edges.

5.3 Turn off the Power



WARNING:

Failing to turn off the system before opening it can cause permanent damage to the system and serious or fatal injury to the user.

Before any maintenance procedures are carried out on the system, make sure the system is turned off.

5.4 SO-DIMM Module Replacement

The AFL3-W15C/W19C-ULT3 has one SO-DIMM module installed. To replace the SO-DIMM module, follow the instructions below.

Step 1: Follow all anti-static procedures. See **Section 5.2**.

Step 2: Turn off the power. See **Section 5.3**.

Step 3: Remove the plastic back cover and the internal aluminum cover. See **Section 3.4** above.

Step 4: Locate the SO-DIMM module (**Figure 5-1**).

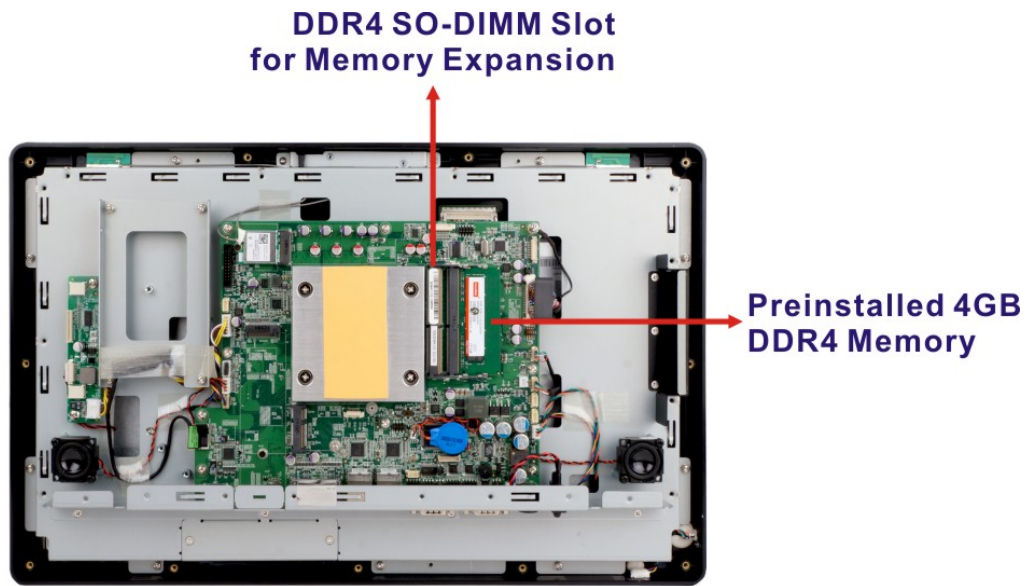

Figure 5-1: SO-DIMM module Location

- Step 5:** Remove the DDR4 memory module by pulling both the spring retainer clips outward from the socket.
- Step 6:** Grasp the DDR4 memory module by the edges and carefully pull it out of the socket.
- Step 7:** Install the new DDR4 memory module by pushing it into the socket at a 20° angle (Figure 5-2).
- Step 8:** Gently push the memory module downwards and the arms clip into place (Figure 5-2).

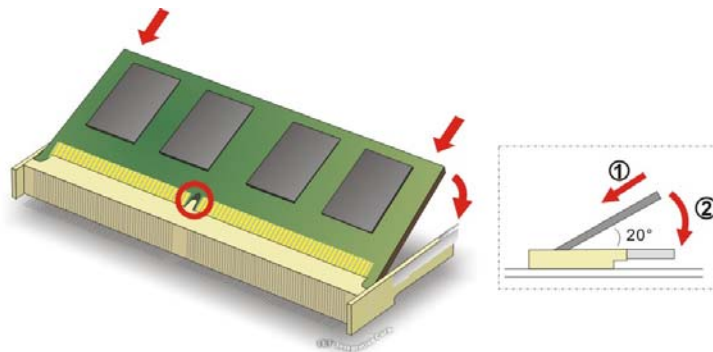

Figure 5-2: SO-DIMM Installation

Step 9: Reinstall the internal aluminum cover and the plastic back cover using the previously removed retention screws.



WARNING:

Failing to reinstall the cover may result in permanent damage to the system. Please make sure all coverings are properly installed.

Chapter

6

Interface Connectors

6.1 Peripheral Interface Connectors

The AFL3-W15C/W19C-ULT3 panel PC motherboard comes with a number of peripheral interface connectors and configuration jumpers. The connector locations are shown in **Figure 6-1**. The Pin 1 locations of the on-board connectors are also indicated in the diagram below. The connector pinouts for these connectors are listed in the following sections.

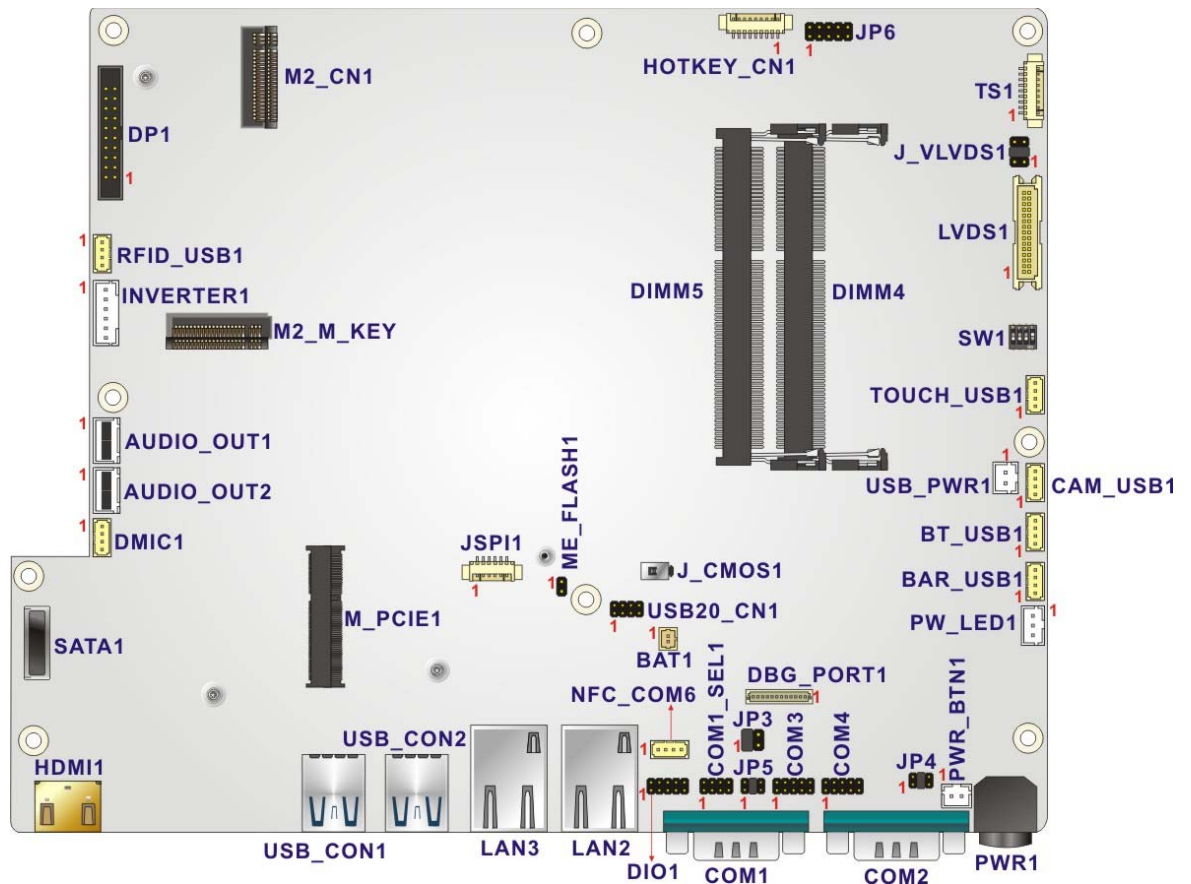

Figure 6-1: Main Board Layout Diagram

AFL3-W15C/W19C-ULT3 Panel PC

6.2 Internal Peripheral Connectors

Internal peripheral connectors are found on the motherboard and are only accessible when the motherboard is outside of the chassis. The table below shows a list of the peripheral interface connectors on the motherboard. Pinouts of these connectors can be found in the following sections.

Connector	Type	Label
Audio connector	4-pin wafer	AUDIO_OUT1
Audio out connector	4-pin wafer	AUDIO_OUT2
Battery connector	2-pin wafer	BAT1
Debug connector	12-pin wafer	DBG_PORT1
Digital I/O connector	10-pin header	DIO1
DisplayPort connector	20-pin box header	DP1
Inverter connector	6-pin wafer	INVERTER1
LVDS connector	30-pin crimp	LVDS1
M.2 slot	M-key slot	M2_M_KEY
M.2 slot (installed with WLAN module)	A-key slot	M2_CN1
MCU connector	9-pin wafer	HOTKEY_CN1
Microphone connector	4-pin wafer	DMIC1
PCIe Mini card slot (support mSATA module)	Full-size/Half-size PCIe Mini slot	M_PCIE1
Power button connector	2-pin wafer	PWR_BTN1
Power LED connector	3-pin wafer	PW_LED1
RS-232 serial port connectors	10-pin header	COM3, COM4
SATA connector	7-pin connector	SATA1
SPI Flash connector	6-pin wafer	JSPI1
Touch panel connector	9-pin wafer	TS1
TTL serial connector (COM6)	4-pin wafer	NFC_COM6

Connector	Type	Label
USB connectors	4-pin wafer	BAR_USB1 BT_USB1 CAM_USB1 RFID_USB1 TOUCH_USB1
USB 2.0 connector	8-pin header	USB20_CN1
USB power connector	2-pin wafer	USB_PWR1

Table 6-1: Peripheral Interface Connectors

6.2.1 Audio Connector (AUDIO_OUT1)

PIN NO.	DESCRIPTION
1	AMP_INL
2	OUT1L
3	OUT1R
4	AMP_INR

Table 6-2: Audio Connector (AUDIO_OUT1) Pinouts

6.2.2 Audio Out Connector (AUDIO_OUT2)

PIN NO.	DESCRIPTION
1	SPK_OUT_P_L
2	SPK_OUT_N_L
3	SPK_OUT_N_R
4	SPK_OUT_P_R

Table 6-3: Audio Out Connector (AUDIO_OUT2) Pinouts

AFL3-W15C/W19C-ULT3 Panel PC

6.2.3 Battery Connector (BAT1)

PIN NO.	DESCRIPTION
1	VBATT
2	GND

Table 6-4: Battery Connector (BAT1) Pinouts

6.2.4 Debug Connector (DBG_PORT1)

PIN NO.	DESCRIPTION	PIN NO.	DESCRIPTION
1	NC	2	+3.3S
3	GND	4	INT_SERIRQ
5	LPC_AD3	6	LPC_AD2
7	LPC_AD1	8	LPC_ADO
9	FRAME#	10	PLT_RST#
11	PLT_CLK	12	GND

Table 6-5: Debug Connector (DBG_PORT1) Pinouts

6.2.5 Digital I/O Connector (DIO1)

PIN NO.	DESCRIPTION	PIN NO.	DESCRIPTION
1	GND	2	+5V
3	DOUT3	4	DOUT2
5	DOUT1	6	DOUT0
7	DIN3	8	DIN2
9	DIN1	10	DINO

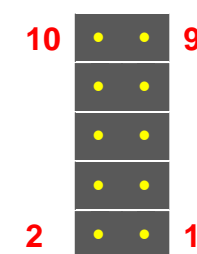

Table 6-6: Digital I/O Connector (DIO1) Pinouts

6.2.6 DisplayPort Connector (DP1)

PIN NO.	DESCRIPTION	PIN NO.	DESCRIPTION
1	DDI2_HPD	2	DDI2_AUXP_R
3	GND	4	DDI2_AUXN_R
5	AUX_CTRL_DET_D	6	GND
7	GND	8	TMDS_TXR2_DP_R
9	TMDS_TXR3_DP_R	10	TMDS_TXN2_DP_R
11	TMDS_TXN3_DP_R	12	GND
13	GND	14	TMDS_TXR0_DP_R
15	TMDS_TXR1_DP_R	16	TMDS_TXN0_DP_R
17	TMDS_TXN1_DP_R	18	+V3.3S
19	+V5S	20	N/C

Table 6-7: DisplayPort Connector (DP1) Pinouts

6.2.7 Inverter Connector (INVERTER1)

PIN NO.	DESCRIPTION
1	+12V
2	+12V
3	ENABKL
4	BRIGHTNESS
5	GND
6	GND

Table 6-8: Inverter Connector (INVERTER1) Pinouts

6.2.8 LVDS Connector (LVDS1)

PIN NO.	DESCRIPTION	PIN NO.	DESCRIPTION
1	GND	2	GND
3	LVDS_A_TX0-P	4	LVDS_A_TX0-N
5	LVDS_A_TX1-P	6	LVDS_A_TX1-N
7	LVDS_A_TX2-P	8	LVDS_A_TX2-N
9	LVDS_A_TXCLK-P	10	LVDS_A_TXCLK-N

AFL3-W15C/W19C-ULT3 Panel PC

11	LVDS_A_TX3-P	12	LVDS_A_TX3-N
13	GND	14	GND
15	LVDS_B_TX0-P	16	LVDS_B_TX0-N
17	LVDS_B_TX1-P	18	LVDS_B_TX1-N
19	LVDS_B_TX2-P	20	LVDS_B_TX2-N
21	LVDS_B_TXCLK-P	22	LVDS_B_TXCLK-N
23	LVDS_B_TX3-P	24	LVDS_B_TX3-N
25	GND	26	GND
27	+LCD Vcc	28	+LCD Vcc
29	+LCD Vcc	30	+LCD Vcc

Table 6-9: LVDS Connector (LVDS1) Pinouts

6.2.9 M.2 M-key Slot (M2_M_KEY)

PIN NO.	DESCRIPTION	PIN NO.	DESCRIPTION
1	GND	2	VCC3
3	GND	4	VCC3
5	PCIE_TXN4	6	N/C
7	PCIE_TXP4	8	N/C
9	GND	10	N/C
11	PCIE_RXN4	12	VCC3
13	PCIE_RXP4	14	VCC3
15	GND	16	VCC3
17	PCIE_TXN3	18	VCC3
19	PCIE_TXP3	20	N/C
21	GND	22	N/C
23	PCIE_RXN3	24	N/C
25	PCIE_RXP3	26	N/C
27	GND	28	N/C
29	PCIE_TXN2	30	N/C
31	PCIE_TXP2	32	N/C
33	GND	34	N/C
35	PCIE_RXN2	36	N/C

37	PCIE_RXP2	38	N/C
39	GND	40	N/C
41	PCIE_TXN1	42	N/C
43	PCIE_TXP1	44	N/C
45	GND	46	N/C
47	PCIE_RXN1	48	N/C
49	PCIE_RXP2	50	PLT_RST#
51	GND	52	PCIeX4_CLKREQ
53	CLK_PCIEX4_N	54	LAN_WAKE#
55	CLK_PCIEX4_P	56	N/C
57	GND	58	N/C
59	N/C	60	N/C
61	N/C	62	N/C
63	N/C	64	N/C
65	N/C	66	N/C
67	N/C	68	N/C
69	N/C	70	GND
71	GND	72	GND
73	GND	74	GND
75	GND		

Table 6-10: M.2 M-key Slot (M2_M_KEY) Pinouts

6.2.10 MCU Connector (HOTKEY_CN1)

PIN NO.	DESCRIPTION
1	+5V
2	AUTO_DIMMING
3	VOL+
4	VOL-
5	BRIGHT+
6	BRIGHT-
7	LCD ON_OFF
8	N/A

AFL3-W15C/W19C-ULT3 Panel PC

9	GND
---	-----

Table 6-11: MCU Connector (HOTKEY_CN1) Pinouts

6.2.11 Microphone Connector (DMIC1)

PIN NO.	DESCRIPTION
1	DMIC_CLK
2	DMIC_DATA
3	+3.3V
4	GND

Table 6-12: Microphone Connector (DMIC1) Pinouts

6.2.12 PCIe Mini Connector, Full-Size/Half-size (M_PCIE1)

PIN NO.	DESCRIPTION	PIN NO.	DESCRIPTION
1	PCIE_WAKE#	2	VCC3
3	N/C	4	GND
5	N/C	6	1.5V
7	N/C	8	N/C
9	GND	10	N/C
11	CLK-	12	N/C
13	CLK+	14	N/C
15	GND	16	N/C
17	PCIRST#	18	GND
19	N/C	20	VCC3
21	GND	22	PCIRST#
23	PERN(SATA_RX1+)	24	3VDual
25	PERP(SATA_RX1-)	26	GND
27	GND	28	1.5V
29	GND	30	SMBCLK
31	PETN(SATA_TX1-)	32	SMBDATA
33	PETP(SATA_TX1+)	34	GND
35	GND	36	USB7-

37	N/C	38	USB D7+
39	N/C	40	GND
41	N/C	42	N/C
43	SATA_DET4_R_N	44	N/C
45	N/C	46	N/C
47	N/C	48	1.5V
49	N/C	50	GND
51	MSATA_SEL#	52	VCC3

Table 6-13: PCIe Mini Connector (M_PCIE1) Pinouts

6.2.13 Power Button Connector (PW_BTN1)

PIN NO.	DESCRIPTION
1	PW_BN
2	GND

Table 6-14: Power Button Connector (PW_BTN1) Pinouts

6.2.14 Power LED Connector (PW_LED1)

PIN NO.	DESCRIPTION
1	PW_LED +5V
2	GND
3	SUS PW LED +5V

Table 6-15: Power LED Connector (PW_LED1) Pinouts

6.2.15 RS-232 Serial Port Connector (COM3)

PIN NO.	DESCRIPTION	PIN NO.	DESCRIPTION
1	-ND CD3	2	-NDSR3
3	NSIN3	4	-NRTS3
5	NSOUT3	6	-NCTS3
7	-NDTR3	8	-XRI3
9	GND	10	NC

Table 6-16: RS-232 Serial Port Connector (COM3) Pinouts

6.2.16 RS-232 Serial Port Connector (COM4)

PIN NO.	DESCRIPTION	PIN NO.	DESCRIPTION
1	-NDCD4	2	-NDSR4
3	NSIN4	4	-NRTS4
5	NSOUT4	6	-NCTS4
7	-NDTR4	8	-XRI4
9	GND	10	NC

Table 6-17: RS-232 Serial Port Connector (COM4) Pinouts

6.2.17 SATA Connector (SATA1)

PIN NO.	DESCRIPTION
1	GND
2	TX+
3	TX-
4	GND
5	RX-
6	RX+
7	GND

Table 6-18: SATA Connector (SATA1) Pinouts

6.2.18 SPI Flash Connector (JSPI1)

PIN NO.	DESCRIPTION
1	+V3.3M_SPI_CON
2	SPI_CS#0_CN
3	SPI_SO_SW
4	SPI_CLK_SW
5	SPI_SI_SW
6	GND

Table 6-19: SPI Flash Connector (JSPI1) Pinouts

6.2.19 Touch Panel Connector (TS1)

PIN NO.	DESCRIPTION		
	8-Wire	4-Wire	5-Wire
1	Right Sense	N/A	N/A
2	Left Sense	N/A	N/A
3	Bottom Sense	N/A	N/A
4	TOP Sense	N/A	Sense(S)
5	Right Excite	Right	LR(X)
6	Left Excite	Left	LL(L)
7	Bottom Excite	Bottom	UR(H)
8	Top Excite	Top	UL(Y)
9	GND	GND	GND

Table 6-20: Touch Panel Connector (TS1) Pinouts

6.2.20 TTL Serial Connector, COM6 (NFC_COM6)

PIN NO.	DESCRIPTION
1	+5V
2	SIN6
3	SOUT6
4	GND

Table 6-21: TTL Serial Connector, COM6 (NFC_COM6) Pinouts

6.2.21 USB Connector (BAR_USB1)

PIN NO.	DESCRIPTION
1	+V5A
2	HUB_D4F-
3	HUB_D4F+
4	GND

Table 6-22: USB Connector (BAR_USB1) Pinouts

AFL3-W15C/W19C-ULT3 Panel PC

6.2.22 USB Connector (BT_USB1)

PIN NO.	DESCRIPTION
1	+V5A
2	HUB_D1F-
3	HUB_D1F+
4	GND

Table 6-23: USB Connector (BT_USB1) Pinouts

6.2.23 USB Connector (CAM_USB1)

PIN NO.	DESCRIPTION
1	+V5A
2	HUB_D2F-
3	HUB_D2F+
4	GND

Table 6-24: USB Connector (CAM_USB1) Pinouts

6.2.24 USB Connector (RFID_USB1)

PIN NO.	DESCRIPTION
1	+V5A
2	HUB_D3F-
3	HUB_D3F+
4	GND

Table 6-25: USB Connector (RFID_USB1) Pinouts

6.2.25 USB Connector (TOUCH_USB1)

PIN NO.	DESCRIPTION
1	+V5A
2	DATA4-
3	DATA4+
4	GND

Table 6-26: USB Connector (TOUCH_USB1) Pinouts

6.2.26 USB 2.0 Connector (USB20_CN1)

PIN NO.	DESCRIPTION	PIN NO.	DESCRIPTION
1	+V5A	2	GND
3	DATA8-	4	DATA9+
5	DATA8+	6	DATA9-
7	GND	8	+5VA

Table 6-27: USB 2.0 Connector (USB20_CN1) Pinouts

6.2.27 USB Power Connector (USB_PWR1)

PIN NO.	DESCRIPTION
1	+V5A
2	GND

Table 6-28: USB Power Connector (USB_PWR1) Pinouts

6.3 External Interface Panel Connectors

The table below lists the rear panel connectors on the AFL3MB-ULT3 motherboard. Pinouts of these connectors can be found in the following sections.

Connector	Type	Label
Ethernet connector	RJ-45	LAN2
Ethernet connector	RJ-45	LAN3
HDMI connector	HDMI connector	HDMI1
Power connector	Power jack	PWR1
RS-232 serial port	D-sub 9	COM2
RS-232/422/485 serial port	D-sub 9	COM1
USB 3.0 connectors	USB 3.0 port	USB_CON1 USB_CON2

Table 6-29: Rear Panel Connectors

6.3.1 Ethernet Connectors (LAN2 & LAN3)

PIN NO.	DESCRIPTION	PIN NO.	DESCRIPTION
1	MDIO+	10	MDI3-
2	MDIO-	11	+3.3V _{sus}
3	MDI1+	12	ACT-1
4	MDI1-	13	LINK1000 +3.3 _{sus}
5	N/A	14	LINK1000 +3.3 _{sus}
6	N/A	15	GND
7	MDI2+	16	GND
8	MDI2-	17	N/A
9	MDI3+	18	N/A

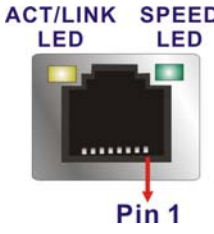

Table 6-30: Ethernet Connectors (LAN2 & LAN3) Pinouts

6.3.2 HDMI Connector (HDMI1)

PIN NO.	DESCRIPTION	PIN NO.	DESCRIPTION
1	HDMI_DATA2+	11	GND
2	GND	12	HDMI_CLK#
3	HDMI_DATA2#-	13	N/C
4	HDMI_DATA1+	14	N/C
5	GND	15	HDMI_SCL
6	HDMI_DATA1#-	16	HDMI_SDA
7	HDMI_DATA0+	17	GND
8	GND	18	+5VCC
9	HDMI_DATA0#-	19	HDMI_HPD
10	HDMI_CLK+		

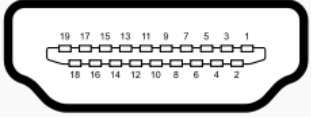

Table 6-31: HDMI Connector (HDMI1) Pinouts

6.3.3 Power Connector (PWR1)



Table 6-32: Power Connector (PWR1) Pinouts

6.3.4 RS-232/422/485 DB-9 Serial Port (COM1)

PIN NO.	DESCRIPTION	PIN NO.	DESCRIPTION
1	NDCD1	6	NDSR1
2	NSIN1	7	NRTS1
3	NSOUT1	8	NCTS1
4	NDTR1	9	XRI1
5	GND		

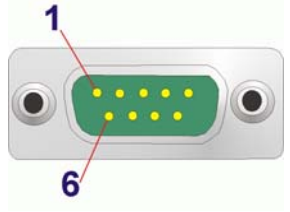

Table 6-33: RS-232/422/485 DB-9 Serial Port (COM1) Pinouts

6.3.5 RS-232 RJ-45 Serial Port (COM2)

PIN NO.	DESCRIPTION	PIN NO.	DESCRIPTION
1	NDCD2	6	NDSR2
2	NSIN2	7	NRTS2
3	NSOUT2	8	NCTS2
4	NRTS2	9	XRI2
5	GND		

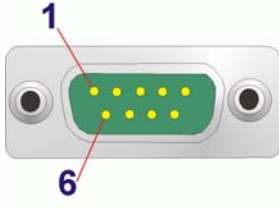

Table 6-34: RS-232 RJ-45 Serial Port (COM2) Pinouts

6.3.6 USB 3.0 Connectors (USB_CON1)

PIN NO.	DESCRIPTION	PIN NO.	DESCRIPTION
1	+5Vsus	10	+5Vsus
2	DATA0-	11	DATA1-
3	DATA0+	12	DATA1+
4	GND	13	GND
5	SSRX0-	14	SSRX1-
6	SSRX0+	15	SSRX1+
7	GND	16	GND
8	SSTX0-	17	SSTX1-
9	SSTX0+	18	SSTX1+

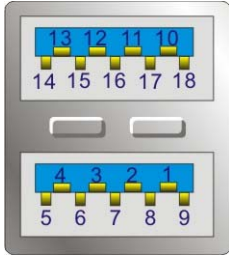

Table 6-35: USB 3.0 Connectors (USB_CON12) Pinouts

6.3.7 USB 3.0 Connectors (USB_CON2)

PIN NO.	DESCRIPTION	PIN NO.	DESCRIPTION
1	+5Vsus	10	+5Vsus
2	DATA2-	11	DATA3-
3	DATA2+	12	DATA3+
4	GND	13	GND
5	SSRX2-	14	SSRX3-
6	SSRX2+	15	SSRX3+
7	GND	16	GND
8	SSTX2-	17	SSTX3-
9	SSTX2+	18	SSTX3+

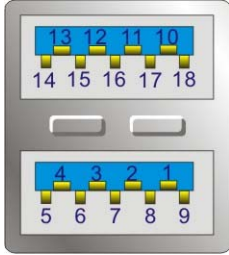

Table 6-36: USB 3.0 Connectors (USB_CON2) Pinouts

6.4 Preconfigured Jumper Settings



CAUTION:

The following jumpers are preconfigured for the AFL3-W15C/W19C-ULT3. Users should not change these jumpers (Table 6-37).

Jumper Name	Type	Label
LVDS voltage selection	3-pin header	J_VLVDS1
LVDS panel resolution selection	Switch	SW1

Table 6-37: Preconfigured Jumpers

AFL3-W15C/W19C-ULT3 Panel PC

6.4.1 LVDS Panel Voltage Selection Jumper (J_VLVDS1)

Pin	Description
Short 1-2	+3.3 V
Short 3-4	+5 V (Default)
Short 5-6	+12 V

Table 6-38: LVDS Voltage Selection Jumper (J_VLVDS1) Settings

6.4.2 LVDS Panel Resolution Selection Jumper (SW1)

* ON=0, OFF=1; Single=S, Dual=D

SW1 (4-3-2-1)	Description
0000	800x600 18bit S (Default)
0001	1024x768 18bit S
0010	1024x768 24bit S
0011	1280x768 18bit S
0100	1280x800 18bit S
0101	1280x960 18bit S
0110	1280x1024 24bit D
0111	1366x768 18bit S
1000	1366x768 24bit S
1001	1440x960 24bit D
1010	1400x1050 24bit D
1011	1600x900 24bit D
1100	1680x1050 24bit D
1101	1600x1200 24bit D
1110	1920x1080 24bit D
1111	1920x1200 24bit D

Table 6-39: LVDS Resolution Selection Jumper (SW1) Settings

Appendix

A

Regulatory Compliance

DECLARATION OF CONFORMITY

This equipment is in conformity with the following EU directives:

- EMC Directive (2004/108/EC, 2014/30/EU)
- Low-Voltage Directive (2006/95/EC, 2014/35/EU)
- RoHS II Directive (2011/65/EU, 2015/863/EU)
- Ecodesign Directive 2009/125/EC

If the user modifies and/or install other devices in the equipment, the CE conformity declaration may no longer apply.

If this equipment has telecommunications functionality, it also complies with the requirements of the Radio Equipment Directive 2014/53/EU.

English

IEI Integration Corp declares that this equipment is in compliance with the essential requirements and other relevant provisions of Directive 2014/53/EU.

Български [Bulgarian]

IEI Integration Corp. декларира, че този оборудване е в съответствие със съществените изисквания и другите приложими правила на Директива 2014/53/EU.

Česky [Czech]

IEI Integration Corp tímto prohlašuje, že tento zařizení je ve shodě se základními požadavky a dalšími příslušnými ustanoveními směrnice 2014/53/EU.

Dansk [Danish]

IEI Integration Corp erklærer herved, at følgende udstyr overholder de væsentlige krav og øvrige relevante krav i direktiv 2014/53/EU.

Deutsch [German]

IEI Integration Corp, erklärt dieses Gerät entspricht den grundlegenden Anforderungen und den weiteren entsprechenden Vorgaben der Richtlinie 2014/53/EU.

Eesti [Estonian]

IEI Integration Corp deklareerib seadme seadme vastavust direktiivi 2014/53/EÜ põhinõuetele ja nimetatud direktiivist tulenevatele teistele asjakohastele sätetele.

Español [Spanish]

IEI Integration Corp declara que el equipo cumple con los requisitos esenciales y cualesquiera otras disposiciones aplicables o exigibles de la Directiva 2014/53/EU.

Ελληνική [Greek]

IEI Integration Corp ΔΗΛΩΝΕΙ ΟΤΙ ΕΞΟΠΛΙΣΜΟΣ ΣΥΜΜΟΡΦΩΝΕΤΑΙ ΠΡΟΣ ΤΙΣ ΟΥΣΙΩΔΕΙΣ ΑΠΑΙΤΗΣΕΙΣ ΚΑΙ ΤΙΣ ΛΟΙΠΕΣ ΣΧΕΤΙΚΕΣ ΔΙΑΤΑΞΕΙΣ ΤΗΣ ΟΔΗΓΙΑΣ 2014/53/EU.

Français [French]

IEI Integration Corp déclare que l'appareil est conforme aux exigences essentielles et aux autres dispositions pertinentes de la directive 2014/53/EU.

Italiano [Italian]

IEI Integration Corp dichiara che questo apparecchio è conforme ai requisiti essenziali ed alle altre disposizioni pertinenti stabilite dalla direttiva 2014/53/EU.

Latviski [Latvian]

IEI Integration Corp deklarē, ka iekārta atbilst būtiskajām prasībām un citiem ar to saistītajiem noteikumiem Direktīvas 2014/53/EU.

Lietuvių [Lithuanian]

IEI Integration Corp deklaruoja, kad šis įranga atitinka esminius reikalavimus ir kitas 2014/53/EU Direktyvos nuostatas.

Nederlands [Dutch]

IEI Integration Corp dat het toestel toestel in overeenstemming is met de essentiële eisen en de andere relevante bepalingen van richtlijn 2014/53/EU.

Malti [Maltese]

IEI Integration Corp jiddikjara li dan prodott jikkonforma mal-ħtiġijiet essenzjali u ma provvedimenti oħrajn relevanti li hemm fid-Dirrettiva 2014/53/EU.

Magyar [Hungarian]

IEI Integration Corp nyilatkozom, hogy a berendezés megfelel a vonatkozó alapvető követelményeknek és az 2014/53/EU irányelv egyéb előírásainak.

Polski [Polish]

IEI Integration Corp oświadcza, że wyrobu jest zgodny z zasadniczymi wymogami oraz pozostałymi stosownymi postanowieniami Dyrektywy 2014/53/EU.

Português [Portuguese]

IEI Integration Corp declara que este equipamento está conforme com os requisitos essenciais e outras disposições da Directiva 2014/53/EU.

AFL3-W15C/W19C-ULT3 Panel PC

Româna [Romanian]

IEI Integration Corp declară că acest echipament este în conformitate cu cerințele esențiale și cu celelalte prevederi relevante ale Directivei 2014/53/EU.

Slovensko [Slovenian]

IEI Integration Corp izjavlja, da je ta opreme v skladu z bistvenimi zahtevami in ostalimi relevantnimi določili direktive 2014/53/EU.

Slovensky [Slovak]

IEI Integration Corp týmto vyhlasuje, že zariadenia spĺňa základné požiadavky a všetky príslušné ustanovenia Smernice 2014/53/EU.

Suomi [Finnish]

IEI Integration Corp vakuuttaa täten että laitteet on direktiivin 2014/53/EU oleellisten vaatimusten ja sitä koskevien direktiivin muiden ehtojen mukainen.

Svenska [Swedish]

IEI Integration Corp förklarar att denna utrustningstyp står i överensstämmelse med de väsentliga egenskapskrav och övriga relevanta bestämmelser som framgår av direktiv 2014/53/EU.

FCC WARNING

This equipment complies with Part 15 of the FCC Rules. Operation is subject to the following two conditions:

- This device may not cause harmful interference, and
- This device must accept any interference received, including interference that may cause undesired operation.

This equipment has been tested and found to comply with the limits for a Class A digital device, pursuant to part 15 of the FCC Rules. These limits are designed to provide reasonable protection against harmful interference when the equipment is operated in a commercial environment. This equipment generates, uses, and can radiate radio frequency energy and, if not installed and used in accordance with the instruction manual, may cause harmful interference to radio communications. Operation of this equipment in a residential area is likely to cause harmful interference in which case the user will be required to correct the interference at his own expense.

Federal Communication Commission Interference Statement

This equipment has been assembled with components that comply with the limits for a Class B digital device, pursuant to Part 15 of the FCC Rules. These limits are designed to provide reasonable protection against harmful interference in a residential installation. This equipment generates, uses and can radiate radio frequency energy and, if not installed and used in accordance with the instructions, may cause harmful interference to radio communications. However, there is no guarantee that interference will not occur in a particular installation. If this equipment does cause harmful interference to radio or television reception, which can be determined by turning the equipment off and on, the user is encouraged to try to correct the interference by one of the following measures:

- Reorient or relocate the receiving antenna.
- Increase the separation between the equipment and receiver.
- Connect the equipment into an outlet on a circuit different from that to which the receiver is connected.
- Consult the dealer or an experienced radio/TV technician for help.

AFL3-W15C/W19C-ULT3 Panel PC

CHINA ROHS



The label on the product indicates the estimated “Environmentally Friendly Use Period” (EFUP). This is an estimate of the number of years that these substances would “not leak out or undergo abrupt change.” This product may contain replaceable sub-assemblies/components which have a shorter EFUP such as batteries and lamps. These components will be separately marked.

Appendix

B

Safety Precautions

**WARNING:**

The precautions outlined in this chapter should be strictly followed. Failure to follow these precautions may result in permanent damage to the AFL3-W15C/W19C-ULT3.

B.1 Safety Precautions

Please follow the safety precautions outlined in the sections that follow:

B.1.1 General Safety Precautions

Please ensure the following safety precautions are adhered to at all times.

- ***Follow the electrostatic precautions*** outlined below whenever the device is opened.
- ***Make sure the power is turned off and the power cord is disconnected*** whenever the AFL3-W15C/W19C-ULT3 is being installed, moved or modified.
- ***To prevent the risk of electric shock, make sure power cord is unplugged from wall socket.*** To fully disengage the power to the unit, please disconnect the power cord from the AC outlet. Refer servicing to qualified service personnel. The AC outlet shall be readily available and accessible.
- ***Do not apply voltage levels that exceed the specified voltage range.*** Doing so may cause fire and/or an electrical shock. Use a power cord that matches the voltage of the power outlet, which has been approved and complies with the safety standard of your particular country.
- ***Electric shocks can occur*** if the AFL3-W15C/W19C-ULT3 chassis is opened when it is running. To avoid risk of electric shock, this device must only be connected to a supply mains with protective earth.
- ***Do not drop or insert any objects*** into the ventilation openings of the AFL3-W15C/W19C-ULT3.

- **If considerable amounts of dust, water, or fluids enter the device**, turn off the power supply immediately, unplug the power cord, and contact the AFL3-W15C/W19C-ULT3 vendor.
- **DO NOT:**
 - Drop the device against a hard surface.
 - Strike or exert excessive force onto the LCD panel.
 - Touch any of the LCD panels with a sharp object
 - In a site where the ambient temperature exceeds the rated temperature

B.1.2 Anti-static Precautions



WARNING:

Failure to take ESD precautions during the installation of the AFL3-W15C/W19C-ULT3 may result in permanent damage to the AFL3-W15C/W19C-ULT3 and severe injury to the user.

Electrostatic discharge (ESD) can cause serious damage to electronic components, including the AFL3-W15C/W19C-ULT3. Dry climates are especially susceptible to ESD. It is therefore critical that whenever the AFL3-W15C/W19C-ULT3 is opened and any of the electrical components are handled, the following anti-static precautions are strictly adhered to.

- **Wear an anti-static wristband:** Wearing a simple anti-static wristband can help to prevent ESD from damaging any electrical component.
- **Self-grounding:** Before handling any electrical component, touch any grounded conducting material. During the time the electrical component is handled, frequently touch any conducting materials that are connected to the ground.
- **Use an anti-static pad:** When configuring or working with an electrical component, place it on an anti-static pad. This reduces the possibility of ESD damage.
- **Only handle the edges of the electrical component:** When handling the electrical component, hold the electrical component by its edges.

B.1.3 Product Disposal

**CAUTION:**

Risk of explosion if battery is replaced by an incorrect type. Only certified engineers should replace the on-board battery.

Dispose of used batteries according to instructions and local regulations.

- Outside the European Union – If you wish to dispose of used electrical and electronic products outside the European Union, please contact your local authority so as to comply with the correct disposal method.
- Within the European Union – The device that produces less waste and is easier to recycle is classified as electronic device in terms of the European Directive 2012/19/EU (WEEE), and must not be disposed of as domestic garbage.

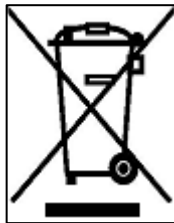

EU-wide legislation, as implemented in each Member State, requires that waste electrical and electronic products carrying the mark (left) must be disposed of separately from normal household waste. This includes monitors and electrical accessories, such as signal cables or power cords. When you need to dispose of your display products, please follow the guidance of your local authority, or ask the shop where you purchased the product. The mark on electrical and electronic products only applies to the current European Union Member States.

Please follow the national guidelines for electrical and electronic product disposal.

B.2 Maintenance and Cleaning Precautions

When maintaining or cleaning the AFL3-W15C/W19C-ULT3, please follow the guidelines below.



WARNING:

- For safety reasons, turn-off the power and unplug the panel PC before cleaning.
 - If you dropped any material or liquid such as water onto the panel PC when cleaning, unplug the power cable immediately and contact your dealer or the nearest service center. Always make sure your hands are dry when unplugging the power cable.
-

B.2.1 Maintenance and Cleaning

Prior to cleaning any part or component of the AFL3-W15C/W19C-ULT3, please read the details below.

- Except for the LCD panel, never spray or squirt liquids directly onto any other components. To clean the LCD panel, gently wipe it with a piece of soft dry cloth or a slightly moistened cloth.
- The interior of the device does not require cleaning. Keep fluids away from the device interior.
- Be cautious of all small removable components when vacuuming the device.
- Never drop any objects or liquids through the openings of the device.
- Be cautious of any possible allergic reactions to solvents or chemicals used when cleaning the device.
- Avoid eating, drinking and smoking within vicinity of the device.

B.2.2 Cleaning Tools

Some components in the AFL3-W15C/W19C-ULT3 may only be cleaned using a product specifically designed for the purpose. In such case, the product will be explicitly mentioned in the cleaning tips. Below is a list of items to use when cleaning the AFL3-W15C/W19C-ULT3.

AFL3-W15C/W19C-ULT3 Panel PC

- **Cloth** – Although paper towels or tissues can be used, a soft, clean piece of cloth is recommended when cleaning the device.
- **Water or rubbing alcohol** – A cloth moistened with water or rubbing alcohol can be used to clean the device.
- **Using solvents** – The use of solvents is not recommended when cleaning the device as they may damage the plastic parts.
- **Vacuum cleaner** – Using a vacuum specifically designed for computers is one of the best methods of cleaning the device. Dust and dirt can restrict the airflow in the device and cause its circuitry to corrode.
- **Cotton swabs** – Cotton swabs moistened with rubbing alcohol or water are excellent tools for wiping hard to reach areas.
- **Foam swabs** – Whenever possible, it is best to use lint free swabs such as foam swabs for cleaning.

Appendix

C

BIOS Menu Options

AFL3-W15C/W19C-ULT3 Panel PC

System Date [xx/xx/xx]	53
System Time [xx:xx:xx]	53
ACPI Sleep State [S3 (Suspend to RAM)]	54
Serial Port [Enabled]	56
Change Settings [Auto]	56
Device Mode [RS232]	57
Serial Port [Enabled]	57
Change Settings [Auto]	57
Serial Port [Enabled]	58
Change Settings [Auto]	58
Serial Port [Enabled]	59
Change Settings [Auto]	59
PC Health Status	60
Wake system with Fixed Time [Disabled]	61
Console Redirection [Disabled]	62
Legacy Serial Redirection Port [COM1]	63
Terminal Type [ANSI]	64
Bits per second [115200]	65
Data Bits [8]	65
Parity [None]	65
Stop Bits [1]	66
Hyper Threading Function [Enabled]	67
Active Processor Cores [All]	67
Intel® Virtualization Technology [Disabled]	67
Intel® SpeedStep™ [Enabled]	67
CPU C State [Disabled]	68
STAT Controller(s) [Enabled]	68
SATA Mode Selection [AHCI]	69
Hot Plug [Disabled]	69
USB Devices	70
Legacy USB Support [Enabled]	70
Auto Recovery Function [Disabled]	71
VT-d [Disabled]	73
Primary Display [Auto]	73

Internal Graphics [Enabled]	74
DVMT Pre-Allocated [256M]	74
DVMT Total Gfx Mem [MAX].....	74
Primary IGFX Boot Display [VBIOS Default]	75
Restore AC Power Loss [Last State]	77
PCIe Speed [Auto].....	77
Detect Non-Compliance Device [Disabled]	78
HD Audio [Enabled]	79
Administrator Password	79
User Password	79
Bootup NumLock State [On].....	80
Quiet Boot [Enabled]	81
UEFI Boot [Disabled]	81
Launch PXE OpROM [Disabled]	81
Option ROM Messages [Force BIOS].....	81
Boot Option Priority.....	81
Save Changes and Reset	82
Discard Changes and Reset	82
Restore Defaults	82
Save as User Defaults	83
Restore User Defaults	83

Appendix

D

Watchdog Timer



NOTE:

The following discussion applies to DOS. Contact IEI support or visit the IEI website for drivers for other operating systems.

The Watchdog Timer is a hardware-based timer that attempts to restart the system when it stops working. The system may stop working because of external EMI or software bugs. The Watchdog Timer ensures that standalone systems like ATMs will automatically attempt to restart in the case of system problems.

A BIOS function call (INT 15H) is used to control the Watchdog Timer.

INT 15H:

AH – 6FH Sub-function:	
AL – 2:	Sets the Watchdog Timer’s period.
BL:	Time-out value (Its unit-second is dependent on the item “Watchdog Timer unit select” in CMOS setup).

Table D-1: AH-6FH Sub-function

Call sub-function 2 to set the time-out period of Watchdog Timer first. If the time-out value is not zero, the Watchdog Timer starts counting down. When the timer value reaches zero, the system resets. To ensure that this reset condition does not occur, calling sub-function 2 must periodically refresh the Watchdog Timer. However, the watchdog timer is disabled if the time-out value is set to zero.

A tolerance of at least 10% must be maintained to avoid unknown routines within the operating system (DOS), such as disk I/O that can be very time-consuming.

AFL3-W15C/W19C-ULT3 Panel PC

**NOTE:**

The Watchdog Timer is activated through software. The software application that activates the Watchdog Timer must also deactivate it when closed. If the Watchdog Timer is not deactivated, the system will automatically restart after the Timer has finished its countdown.

EXAMPLE PROGRAM:

; INITIAL TIMER PERIOD COUNTER

;

W_LOOP:

;

```

MOV      AX, 6F02H      ;setting the time-out value
MOV      BL, 30         ;time-out value is 48 seconds
INT      15H

```

;

; ADD THE APPLICATION PROGRAM HERE

;

```

CMP      EXIT_AP, 1     ;is the application over?
JNE      W_LOOP        ;No, restart the application

MOV      AX, 6F02H     ;disable Watchdog Timer
MOV      BL, 0         ;
INT      15H

```

;

; EXIT ;

Appendix

E

Hazardous Materials Disclosure

AFL3-W15C/W19C-ULT3 Panel PC

The details provided in this appendix are to ensure that the product is compliant with the Peoples Republic of China (China) RoHS standards. The table below acknowledges the presences of small quantities of certain materials in the product, and is applicable to China RoHS only.

A label will be placed on each product to indicate the estimated “Environmentally Friendly Use Period” (EFUP). This is an estimate of the number of years that these substances would “not leak out or undergo abrupt change.” This product may contain replaceable sub-assemblies/components which have a shorter EFUP such as batteries and lamps. These components will be separately marked.

Please refer to the following table.

Part Name	Toxic or Hazardous Substances and Elements					
	Lead (Pb)	Mercury (Hg)	Cadmium (Cd)	Hexavalent Chromium (CR(VI))	Polybrominated Biphenyls (PBB)	Polybrominated Diphenyl Ethers (PBDE)
Housing	O	O	O	O	O	O
Display	O	O	O	O	O	O
Printed Circuit Board	O	O	O	O	O	O
Metal Fasteners	O	O	O	O	O	O
Cable Assembly	O	O	O	O	O	O
Fan Assembly	O	O	O	O	O	O
Power Supply Assemblies	O	O	O	O	O	O
Battery	O	O	O	O	O	O

O: This toxic or hazardous substance is contained in all of the homogeneous materials for the part is below the limit requirement in SJ/T11363-2006 (now replaced by GB/T 26572-2011).

X: This toxic or hazardous substance is contained in at least one of the homogeneous materials for this part is above the limit requirement in SJ/T11363-2006 (now replaced by GB/T 26572-2011).

此附件旨在确保本产品符合中国 RoHS 标准。以下表格标示此产品中某有毒物质的含量符合中国 RoHS 标准规定的限量要求。

本产品上会附有“环境友好使用期限”的标签，此期限是估算这些物质“不会有泄漏或突变”的年限。本产品可能包含有较短的环境友好使用期限的可替换元件，像是电池或灯管，这些元件将会单独标示出来。

部件名称	有毒有害物质或元素					
	铅 (Pb)	汞 (Hg)	镉 (Cd)	六价铬 (CR(VI))	多溴联苯 (PBB)	多溴二苯 醚 (PBDE)
壳体	○	○	○	○	○	○
显示	○	○	○	○	○	○
印刷电路板	○	○	○	○	○	○
金属螺帽	○	○	○	○	○	○
电缆组装	○	○	○	○	○	○
风扇组装	○	○	○	○	○	○
电力供应组装	○	○	○	○	○	○
电池	○	○	○	○	○	○

○: 表示该有毒有害物质在该部件所有物质材料中的含量均在 SJ/T 11363-2006 (现由 GB/T 26572-2011 取代) 标准规定的限量要求以下。

X: 表示该有毒有害物质至少在该部件的某一均质材料中的含量超出 SJ/T 11363-2006 (现由 GB/T 26572-2011 取代) 标准规定的限量要求。