

MODEL:
KINO-AQ870

Mini-ITX SBC with Intel® Haswell CPU, DVI-D / VGA / DP,
Dual Intel® PCIe GbE, USB 3.0, SATA 6Gb/s,
HD Audio and RoHS

User Manual

Revision

Date	Version	Changes
13 August, 2014	1.02	Update Table 3 -16: Serial Port Connector Pinouts
1 April, 2014	1.01	Update memory socket type to DIMM slot
29 May, 2013	1.00	Initial release

Copyright

COPYRIGHT NOTICE

The information in this document is subject to change without prior notice in order to improve reliability, design and function and does not represent a commitment on the part of the manufacturer.

In no event will the manufacturer be liable for direct, indirect, special, incidental, or consequential damages arising out of the use or inability to use the product or documentation, even if advised of the possibility of such damages.

This document contains proprietary information protected by copyright. All rights are reserved. No part of this manual may be reproduced by any mechanical, electronic, or other means in any form without prior written permission of the manufacturer.

TRADEMARKS

All registered trademarks and product names mentioned herein are used for identification purposes only and may be trademarks and/or registered trademarks of their respective owners.

Table of Contents

1 INTRODUCTION.....	1
1.1 INTRODUCTION.....	2
1.2 FEATURES.....	3
1.3 CONNECTORS	4
1.4 DIMENSIONS.....	5
1.5 DATA FLOW	6
1.6 TECHNICAL SPECIFICATIONS	7
2 UNPACKING	9
2.1 ANTI-STATIC PRECAUTIONS	10
2.2 UNPACKING PRECAUTIONS.....	10
2.3 PACKING LIST.....	11
2.4 OPTIONAL ITEMS	12
3 CONNECTORS	14
3.1 PERIPHERAL INTERFACE CONNECTORS.....	15
3.1.1 KINO-AQ870 Layout	15
3.1.2 Peripheral Interface Connectors	16
3.1.3 External Interface Panel Connectors.....	17
3.2 INTERNAL PERIPHERAL CONNECTORS	17
3.2.1 ATX Power Connector	17
3.2.2 AT/ATX Mode Select Switch.....	18
3.2.3 Battery Connector.....	19
3.2.4 Clear CMOS Button.....	20
3.2.5 CPU Power Connector	21
3.2.6 DDR3 DIMM Slots.....	22
3.2.7 Digital I/O Connector	23
3.2.8 Display Port Connector	23
3.2.9 Fan Connector (CPU).....	25
3.2.10 Fan Connector (System)	25
3.2.11 Front Panel Connector.....	26

KINO-AQ870

3.2.12 Keyboard/Mouse Connector	27
3.2.13 LAN LED Connector.....	28
3.2.14 PCIe x4 Slot	29
3.2.15 PCIe Mini Card Slot	30
3.2.16 SATA 6Gb/s Drive Connectors.....	31
3.2.17 Serial Port Connector, RS-422/485.....	31
3.2.18 Serial Port Connectors, RS-232.....	32
3.2.19 SMBUS Connector.....	33
3.2.20 TPM Connector.....	34
3.2.21 USB Connectors.....	35
3.3 EXTERNAL PERIPHERAL INTERFACE CONNECTOR PANEL	37
3.3.1 Audio Connector	37
3.3.2 Ethernet and USB Connectors.....	38
3.3.3 Keyboard/Mouse Connector	40
3.3.4 RS-232 Serial Port Connectors.....	40
3.3.5 VGA and DVI Connector	41
4 INSTALLATION	43
4.1 ANTI-STATIC PRECAUTIONS	44
4.2 INSTALLATION CONSIDERATIONS.....	45
4.3 BASIC INSTALLATION	46
4.3.1 Socket LGA1150 CPU Installation	46
4.3.2 Cooling Kit Installation	49
4.3.3 DIMM Installation	50
4.4 INTERNAL PERIPHERAL DEVICE CONNECTIONS.....	52
4.4.1 SATA Drive Connection	52
4.5 EXTERNAL PERIPHERAL INTERFACE CONNECTION	53
4.5.1 Audio Connection.....	54
4.5.2 DVI Display Device Connection.....	54
4.5.3 LAN Connection.....	55
4.5.4 PS/2 Keyboard and Mouse Connection	56
4.5.5 Serial Device Connection	57
4.5.6 USB Connection.....	58
4.5.7 VGA Monitor Connection	59
4.6 INTEL® AMT SETUP PROCEDURE.....	60

5 BIOS	62
5.1 INTRODUCTION.....	63
5.1.1 Starting Setup.....	63
5.1.2 Using Setup.....	63
5.1.3 Getting Help.....	64
5.1.4 Unable to Reboot after Configuration Changes.....	64
5.1.5 BIOS Menu Bar.....	64
5.2 MAIN.....	65
5.3 ADVANCED.....	66
5.3.1 ACPI Configuration.....	67
5.3.2 Trusted Computing.....	68
5.3.3 CPU Configuration.....	70
5.3.4 SATA Configuration.....	71
5.3.5 Intel(R) Rapid Start Technology.....	72
5.3.6 AMT Configuration.....	72
5.3.7 USB Configuration.....	74
5.3.8 F81866 Super IO Configuration.....	75
5.3.8.1 Serial Port n Configuration.....	76
5.3.9 F81866 H/W Monitor.....	81
5.3.9.1 Smart Fan Mode Configuration.....	82
5.3.10 Serial Port Console Redirection.....	83
5.3.10.1 Console Redirection Settings.....	84
5.3.11 IEI Feature.....	87
5.4 CHIPSET.....	88
5.4.1 PCH-IO Configuration.....	89
5.4.1.1 PCH Azalia Configuration.....	90
5.4.2 System Agent (SA) Configuration.....	91
5.4.2.1 Graphics Configuration.....	91
5.5 BOOT.....	94
5.6 SECURITY.....	96
5.7 EXIT.....	96
A BIOS MENU OPTIONS	98
B ONE KEY RECOVERY	101

KINO-AQ870

B.1 ONE KEY RECOVERY INTRODUCTION	102
<i>B.1.1 System Requirement.....</i>	<i>103</i>
<i>B.1.2 Supported Operating System.....</i>	<i>104</i>
B.2 SETUP PROCEDURE FOR WINDOWS	105
<i>B.2.1 Hardware and BIOS Setup</i>	<i>106</i>
<i>B.2.2 Create Partitions</i>	<i>106</i>
<i>B.2.3 Install Operating System, Drivers and Applications.....</i>	<i>110</i>
<i>B.2.4 Building the Recovery Partition.....</i>	<i>111</i>
<i>B.2.5 Create Factory Default Image.....</i>	<i>113</i>
B.3 AUTO RECOVERY SETUP PROCEDURE.....	118
B.4 SETUP PROCEDURE FOR LINUX.....	122
B.5 RECOVERY TOOL FUNCTIONS	126
<i>B.5.1 Factory Restore</i>	<i>127</i>
<i>B.5.2 Backup System.....</i>	<i>128</i>
<i>B.5.3 Restore Your Last Backup.....</i>	<i>129</i>
<i>B.5.4 Manual.....</i>	<i>130</i>
B.6 RESTORE SYSTEMS FROM A LINUX SERVER THROUGH LAN	131
<i>B.6.1 Configure DHCP Server Settings</i>	<i>132</i>
<i>B.6.2 Configure TFTP Settings.....</i>	<i>133</i>
<i>B.6.3 Configure One Key Recovery Server Settings.....</i>	<i>134</i>
<i>B.6.4 Start the DHCP, TFTP and HTTP</i>	<i>135</i>
<i>B.6.5 Create Shared Directory.....</i>	<i>135</i>
<i>B.6.6 Setup a Client System for Auto Recovery</i>	<i>136</i>
B.7 OTHER INFORMATION	139
<i>B.7.1 Using AHCI Mode or ALi M5283 / VIA VT6421A Controller.....</i>	<i>139</i>
<i>B.7.2 System Memory Requirement</i>	<i>141</i>
C TERMINOLOGY	142
D WATCHDOG TIMER	147
E HAZARDOUS MATERIALS DISCLOSURE	150
E.1 HAZARDOUS MATERIAL DISCLOSURE TABLE FOR IPB PRODUCTS CERTIFIED AS ROHS COMPLIANT UNDER 2002/95/EC WITHOUT MERCURY	151

List of Figures

Figure 1-1: KINO-AQ870.....	2
Figure 1-2: Connectors	4
Figure 1-3: KINO-AQ870 Dimensions (mm)	5
Figure 1-4: Data Flow Diagram.....	6
Figure 3-1: Connector and Jumper Locations.....	15
Figure 3-2: ATX Power Connector Location	18
Figure 3-3: AT/ATX Mode Select Switch Location	19
Figure 3-4: Battery Connector Location.....	20
Figure 3-5: Clear CMOS Button Location.....	21
Figure 3-6: CPU Power Connector Location.....	21
Figure 3-7: DDR3 DIMM Slot Locations	22
Figure 3-8: Digital I/O Connector Location	23
Figure 3-9: Display Port Connector Location	24
Figure 3-10: CPU Fan Connector Locations	25
Figure 3-11: System Fan Connector Location	26
Figure 3-12: Front Panel Connector Location	27
Figure 3-13: Keyboard/Mouse Connector Location	28
Figure 3-14: LAN LED Connector Location	29
Figure 3-15: PCIe x4 Slot Location	30
Figure 3-16: PCIe Mini Card Slot Location.....	30
Figure 3-17: SATA 6Gb/s Drive Connector Locations	31
Figure 3-18: RS-422/485 Connector Location.....	32
Figure 3-19: Serial Port Connector Location	33
Figure 3-20: SMBus Connector Location	34
Figure 3-21: TPM Connector Location.....	35
Figure 3-22: USB Connector Locations.....	36
Figure 3-23: KINO-AQ870 External Peripheral Interface Connector	37
Figure 3-24: Audio Connector	38
Figure 3-25: LAN Connector	38
Figure 3-26: RS-232 Serial Port Connector	40
Figure 3-27: VGA Connector	41

KINO-AQ870

Figure 4-1: Disengage the CPU Socket Load Lever.....	47
Figure 4-2: Remove Protective Cover.....	47
Figure 4-3: Insert the Socket LGA1150 CPU.....	48
Figure 4-4: Close the Socket LGA1150.....	49
Figure 4-5: Cooling Kit Support Bracket.....	50
Figure 4-6: DIMM Installation.....	51
Figure 4-7: SATA Drive Cable Connection.....	52
Figure 4-8: SATA Power Drive Connection.....	53
Figure 4-9: Audio Connector.....	54
Figure 4-10: DVI Connector.....	55
Figure 4-11: LAN Connection.....	56
Figure 4-12: PS/2 Keyboard/Mouse Connector.....	57
Figure 4-13: Serial Device Connector.....	58
Figure 4-14: USB Connector.....	59
Figure 4-15: VGA Connector.....	60
Figure B-1: IEI One Key Recovery Tool Menu.....	102
Figure B-2: Launching the Recovery Tool.....	107
Figure B-3: Recovery Tool Setup Menu.....	107
Figure B-4: Command Prompt.....	108
Figure B-5: Partition Creation Commands.....	109
Figure B-6: Launching the Recovery Tool.....	111
Figure B-7: Manual Recovery Environment for Windows.....	111
Figure B-8: Building the Recovery Partition.....	112
Figure B-9: Press Any Key to Continue.....	112
Figure B-10: Press F3 to Boot into Recovery Mode.....	113
Figure B-11: Recovery Tool Menu.....	113
Figure B-12: About Symantec Ghost Window.....	114
Figure B-13: Symantec Ghost Path.....	114
Figure B-14: Select a Local Source Drive.....	115
Figure B-15: Select a Source Partition from Basic Drive.....	115
Figure B-16: File Name to Copy Image to.....	116
Figure B-17: Compress Image.....	116
Figure B-18: Image Creation Confirmation.....	117
Figure B-19: Image Creation Complete.....	117
Figure B-20: Image Creation Complete.....	117

Figure B-21: Press Any Key to Continue	118
Figure B-22: Auto Recovery Utility	119
Figure B-23: Launching the Recovery Tool	119
Figure B-24: Auto Recovery Environment for Windows	119
Figure B-25: Building the Auto Recovery Partition.....	120
Figure B-26: Factory Default Image Confirmation	120
Figure B-27: Image Creation Complete	121
Figure B-28: Press any key to continue	121
Figure B-29: Partitions for Linux.....	123
Figure B-30: Manual Recovery Environment for Linux	124
Figure B-31: Access menu.lst in Linux (Text Mode).....	125
Figure B-32: Recovery Tool Menu	125
Figure B-33: Recovery Tool Main Menu	126
Figure B-34: Restore Factory Default	127
Figure B-35: Recovery Complete Window	128
Figure B-36: Backup System.....	128
Figure B-37: System Backup Complete Window	129
Figure B-38: Restore Backup	129
Figure B-39: Restore System Backup Complete Window	130
Figure B-40: Symantec Ghost Window	130

List of Tables

Table 1-1: Technical Specifications	8
Table 3-1: Peripheral Interface Connectors	17
Table 3-2: Rear Panel Connectors	17
Table 3-3: ATX Power Connector Pinouts.....	18
Table 3-4: AT/ATX Mode Select Switch Settings.....	19
Table 3-5: Battery Connector Pinouts	20
Table 3-6: Clear CMOS Button Settings	20
Table 3-7: CPU Power Connector Pinouts	22
Table 3-8: Digital I/O Connector Pinouts.....	23
Table 3-9: Display Port Connector Pinouts	24
Table 3-10: CPU Fan Connector Pinouts.....	25
Table 3-11: System Fan Connector Pinouts	26
Table 3-12: Front Panel Connector Pinouts.....	27
Table 3-13: Keyboard/Mouse Connector Pinouts	28
Table 3-14: LAN LED Connector Pinouts	29
Table 3-15: RS-422/485 Connector Pinouts	32
Table 3-16: Serial Port Connector Pinouts	33
Table 3-17: SMBus Connector Pinouts	34
Table 3-18: TPM Connector Pinouts	35
Table 3-19: USB 2.0 Connector Pinouts (USB1, USB2)	36
Table 3-20: USB 3.0 Connector Pinouts (CN4)	36
Table 3-21: LAN2_USB2 Connector Pinouts	39
Table 3-22: LAN1_USB1 Connector Pinouts	39
Table 3-23: PS/2 Connector Pinouts.....	40
Table 3-24: RS-232 Serial Port Connector Pinouts	41
Table 3-25: VGA Connector Pinouts.....	42
Table 3-26: DVI Connector Pinouts.....	42
Table 5-1: BIOS Navigation Keys	64

List of BIOS Menus

BIOS Menu 1: Main	66
BIOS Menu 2: Advanced	67
BIOS Menu 3: ACPI Configuration	67
BIOS Menu 4: Trusted Computing	69
BIOS Menu 5: CPU Configuration	70
BIOS Menu 6: SATA Configuration	71
BIOS Menu 7: Intel(R) Rapid Start Technology	72
BIOS Menu 8: AMT Configuration	73
BIOS Menu 9: USB Configuration	74
BIOS Menu 10: Super IO Configuration.....	75
BIOS Menu 11: Serial Port n Configuration Menu	76
BIOS Menu 12: Hardware Health Configuration	81
BIOS Menu 13: FAN 1 Configuration	82
BIOS Menu 14: Serial Port Console Redirection	84
BIOS Menu 15: Console Redirection Settings.....	85
BIOS Menu 16: IEI Feature	87
BIOS Menu 17: Chipset	88
BIOS Menu 18:PCH-IO Configuration	89
BIOS Menu 19:PCH-IO Configuration	90
BIOS Menu 20: System Agent (SA) Configuration	91
BIOS Menu 21: Graphics Configuration	92
BIOS Menu 22: Graphics Configuration	93
BIOS Menu 23: Boot	94
BIOS Menu 24: Security	96
BIOS Menu 25:Exit.....	97
BIOS Menu 26: IEI Feature	122

Chapter

1

Introduction

1.1 Introduction



Figure 1-1: KINO-AQ870

The KINO-AQ870 is a Mini-ITX motherboard. It accepts a LGA1150 Intel® Haswell processor and supports two 204-pin 1066/1333/1600 MHz dual-channel DDR3 SDRAM unbuffered DIMMs up to 16 GB.

The integrated Intel® Q87 System Chipset supports two GbE LAN: one through the Intel® I217LM with Intel® AMT supported and the other through the Intel® I211 PCIe controller.

The KINO-AQ870 includes a VGA connector and a DVI-D connector. Expansion and I/O include one PCIe x4 slot, two USB 3.0 connectors on the rear panel, two USB 3.0 connectors by pin header, two USB 2.0 connectors on the rear panel, four USB 2.0 connectors by pin header and four SATA 6Gb/s connectors. Serial device connectivity is provided by one internal RS-422/485 connector, two external RS-232 connectors and three internal RS-232 connectors.

KINO-AQ870

1.2 Features

Some of the KINO-AQ870 motherboard features are listed below:

- LGA1150 Intel® Haswell processor supported
- DDR3 1066/1333/1600 MHz dual channel SDRAM
- 3D micro-architecture enhancements supports for DX11.1, OCL 1.2 and OGL3.2
- Rich media acceleration for hardware decode and encode acceleration
- Intel® GbE Lan with Intel® AMT 9.0 supported
- High speed I/O interface for USB 3.0, SATA 6Gb/s and mSATA supported
- IEI Jumper-less function

1.3 Connectors

The connectors on the KINO-AQ870 are shown in the figure below.

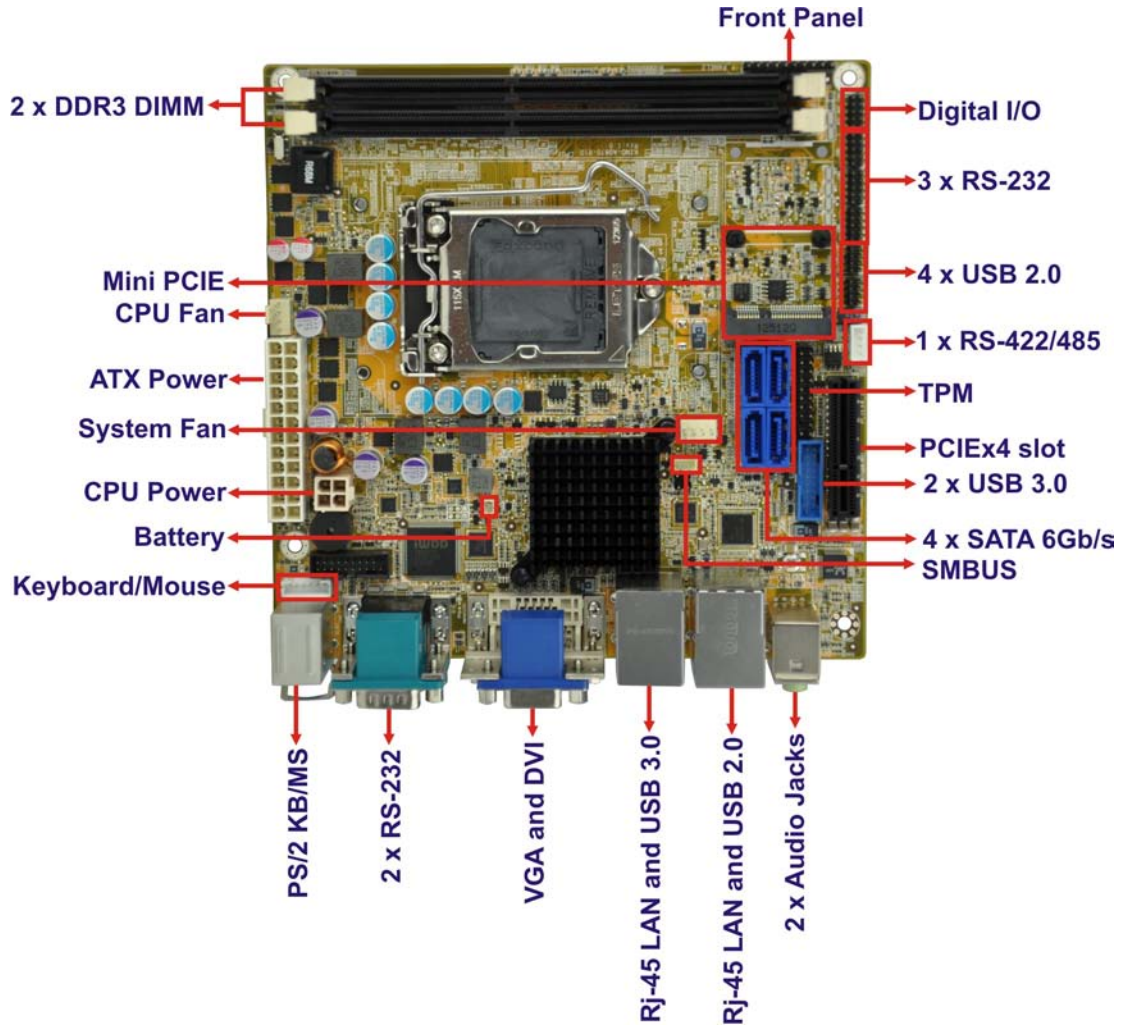

Figure 1-2: Connectors

KINO-AQ870

1.4 Dimensions

The dimensions of the board are listed below:

- **Length:** 170 mm
- **Width:** 170 mm

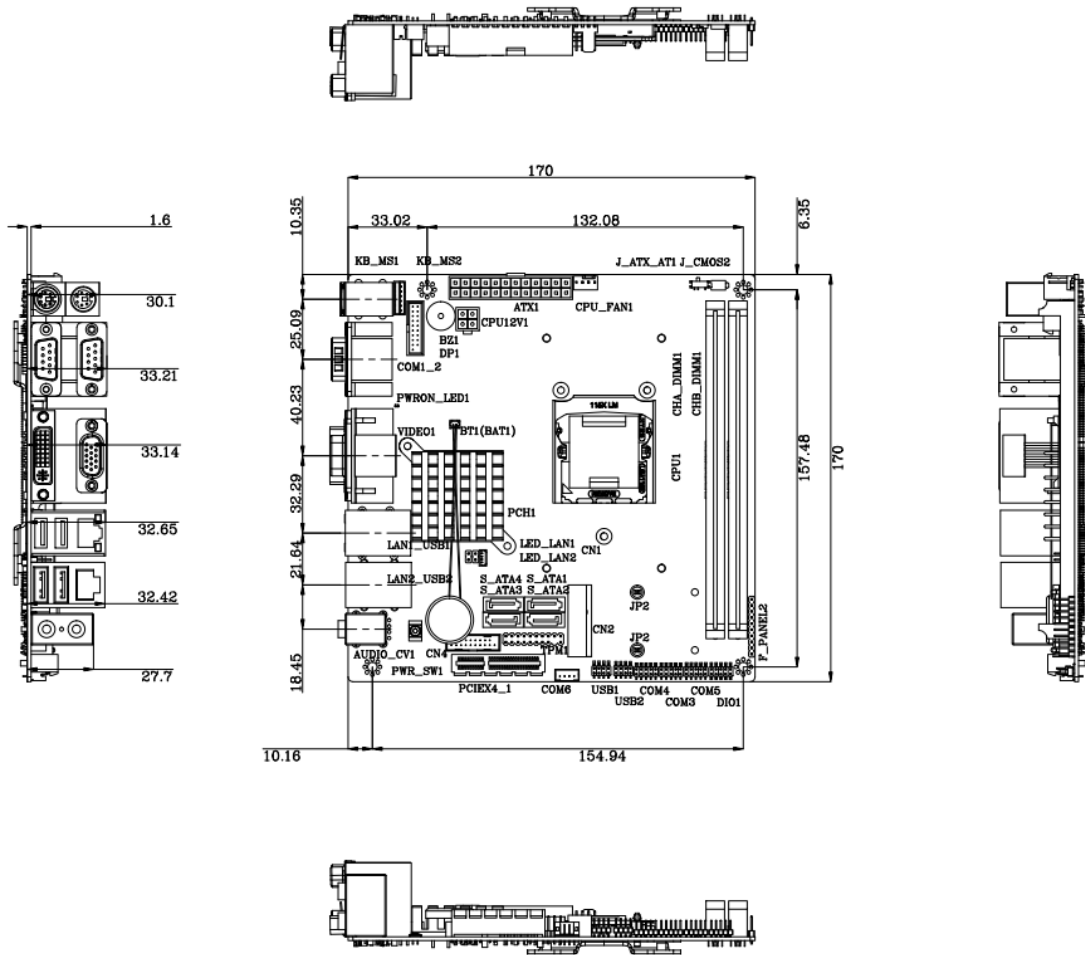

Figure 1-3: KINO-AQ870 Dimensions (mm)

1.5 Data Flow

Figure 1-4 shows the data flow between the system chipset, the CPU and other components installed on the motherboard.

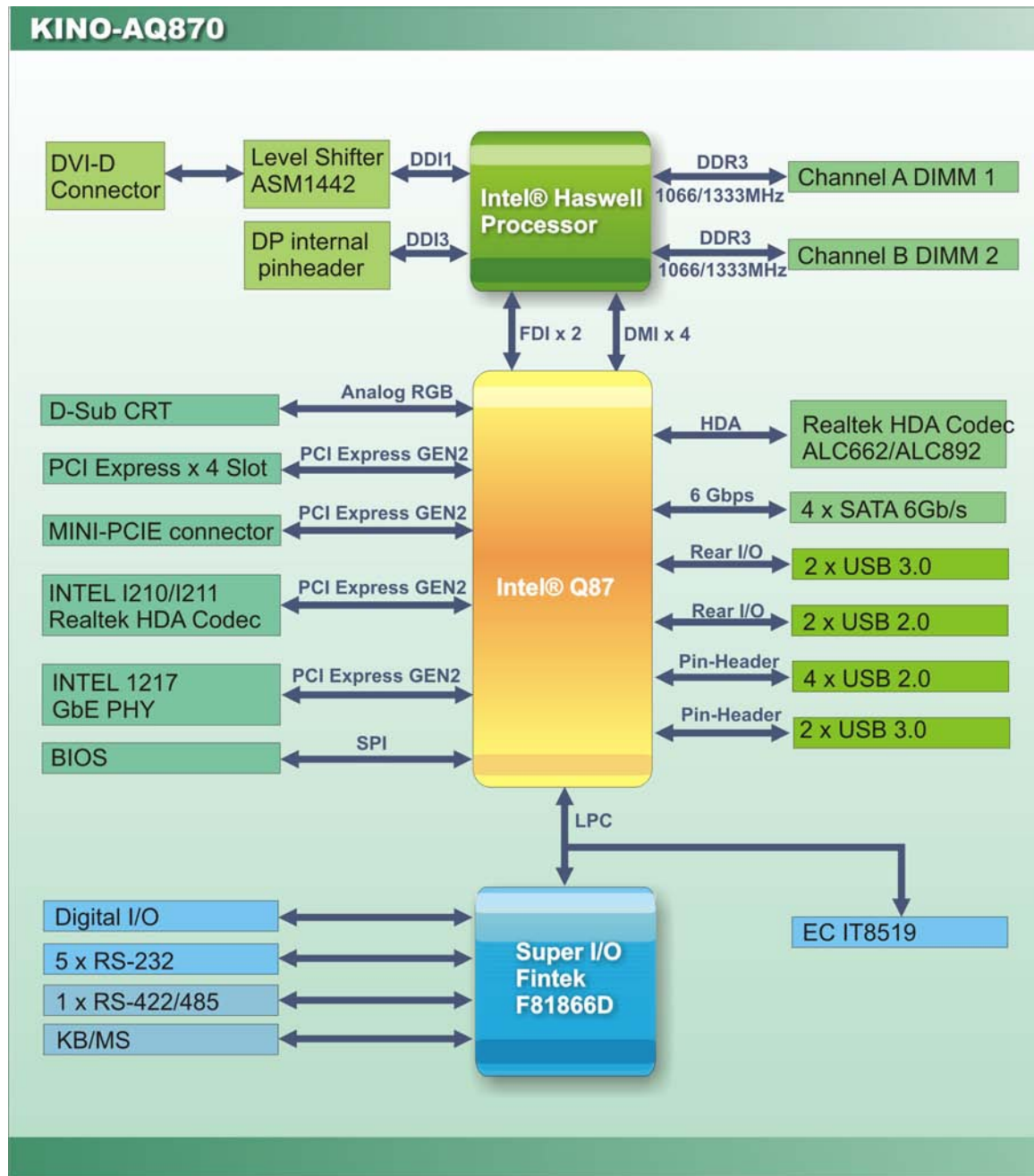

Figure 1-4: Data Flow Diagram

KINO-AQ870**1.6 Technical Specifications**

KINO-AQ870 technical specifications are listed below.

Specification	KINO-AQ870
CPU	LGA1150 socket supports Intel® Haswell processor
PCH	Intel® Q87
Memory	Two 240-pin 1066/1333/1600 MHz dual-channel DDR3 SDRAM Unbuffered DIMM supported (system max. 16GB)
BIOS	UEFI BIOS
Ethernet	Intel® I211 PCIe controller Intel® I217LM with Intel® AMT supported
Graphic Engine	Support for DX11.1 and OpenGL3.2 Full MPEG2, VC1, AVC Decode
Display Output	DVI-D integrated in the CPU VGA integrated in the Intel® Q87 DisplayPort integrated in the CPU (pin header for changing to HDMI, LVDS, VGA)
Super I/O	Fintek F81866
EC	ITE 8519
Audio	Realtek ALC662 HD Audio codec
Digital I/O	8-bit digital I/O (4-bit input, 4-bit output)
Watchdog Timer	Software programmable supports 1~255 sec. system reset
Expansions	
PCIe	1 x PCIe4 slot 1 x Mini PCIe card slot (colay mSATA)
I/O Interface Connectors	
Audio Connector	Two external audio jacks (Line-out, Mic)
Ethernet	Two RJ-45 ports

Specification	KINO-AQ870
Keyboard/Mouse	1 x 6-pin wafer for PS/2 KB/MS 1 x 6-pin connector for PS2 KB/MS (Rear I/O)
TPM	1 x 20-pin header
SMBus	1 x 4-pin wafer
Fan	1 x 4-pin CPU fan connector 1 x 4-pin system fan connector
Serial Ports	5 x RS-232 (2x Rear I/O, 3x pin header) 1 x RS-422/485 via 4-pin wafer
USB Ports	4 x USB3.0 (2x Rear I/O, 2x pin header) 6 x USB2.0 (2x Rear I/O, 4x pin header)
Front Panel	1 x Front Panel (Power LED, HDD LED, Speaker, Power Button, Reset Button)
LAN LED	2 x 2-pin header for LAN1 LED, LAN2 LED
Storage	
Serial ATA	4 x SATA 6Gb/s with raid support
Environmental and Power Specifications	
Power Supply	ATX Power Supply
Power Consumption	3.3V@1.11A, 5V@3.01A, 12V@0.12A, Vcore@6.32A, 5VSB@0.15A (Intel® 2.60GHz CPU with two 1600MHz 2GB DDR3 memory)
Operating Temperature	-20°C ~ 60°C
Humidity	5% ~ 95% (non-condensing)
Physical Specifications	
Dimensions	170 mm x 170 mm
Weight GW/NW	900 g / 450 g

Table 1-1: Technical Specifications

Chapter

2

Unpacking

2.1 Anti-static Precautions



WARNING!

Static electricity can destroy certain electronics. Make sure to follow the ESD precautions to prevent damage to the product, and injury to the user.

Make sure to adhere to the following guidelines:

- **Wear an anti-static wristband:** Wearing an anti-static wristband can prevent electrostatic discharge.
- **Self-grounding:** Touch a grounded conductor every few minutes to discharge any excess static buildup.
- **Use an anti-static pad:** When configuring any circuit board, place it on an anti-static mat.
- **Only handle the edges of the PCB:** Don't touch the surface of the motherboard. Hold the motherboard by the edges when handling.

2.2 Unpacking Precautions

When the KINO-AQ870 is unpacked, please do the following:

- Follow the antistatic guidelines above.
- Make sure the packing box is facing upwards when opening.
- Make sure all the packing list items are present.

KINO-AQ870







2.3 Packing List



NOTE:

If any of the components listed in the checklist below are missing, do not proceed with the installation. Contact the IEI reseller or vendor the KINO-AQ870 was purchased from or contact an IEI sales representative directly by sending an email to sales@iei.com.tw.







The KINO-AQ870 is shipped with the following components:

Quantity	Item and Part Number	Image
1	KINO-AQ870 motherboard	
4	SATA cable (P/N: 32801-000703-200-RS)	
1	I/O shielding (P/N: 45014-0008C0-00-RS)	
1	Mini jumper pack (2.0mm)	
1	Utility CD	
1	One Key Recovery CD	





1	Quick Installation Guide	
---	--------------------------	---

2.4 Optional Items

The following are optional components which may be separately purchased:

Item and Part Number	Image
Dual-port USB cable without bracket (P/N: 32000-070301-RS)	
RS232 cable, 200mm (P/N: 32200-000049-RS)	
RS-422/485 cable, 200mm (P/N: 32200-074800-RS)	
USB 3.0 cable with bracket (P/N: 19800-010500-100-RS)	
DisplayPort cable (P/N: 32034-000200-100-RS)	
DisplayPort to 24 bit dual channel LVDS converter board (For iEi IDP connector) (P/N: DP-LVDS-R10)	
DisplayPort to HDMI converter board (For iEi IDP connector) (P/N: DP-HDMI-R10)	

KINO-AQ870

<p>DisplayPort to DVI-D converter board (For iEi IDP connector) (P/N: DP-DVI-R10)</p>	
<p>DisplayPort to VGA converter board (For iEi IDP connector) (P/N: DP-VGA-R10)</p>	
<p>Special cooler kit for LGA1150, High-performance compatible, 95W (P/N: CF-1150SA-RS)</p>	
<p>Special cooler kit for LGA1150, High-performance compatible, 65W (P/N: CF-1150SB-RS)</p>	
<p>Special cooler kit for LGA1150, 1U chassis compatible, 65W (P/N: CF-1150SC-RS) 32200-000049-RS</p>	
<p>Special cooler kit for LGA1150, 1U chassis compatible, 35W (P/N: CF-1150SD-RS)</p>	
<p>20-pin Infineon TPM module, software management tool, firmware V3.17 (P/N: TPM-IN01-R11)</p>	

Chapter

3

Connectors

KINO-AQ870

3.1 Peripheral Interface Connectors

This chapter details all the jumpers and connectors.

3.1.1 KINO-AQ870 Layout

The figures below show all the connectors and jumpers.

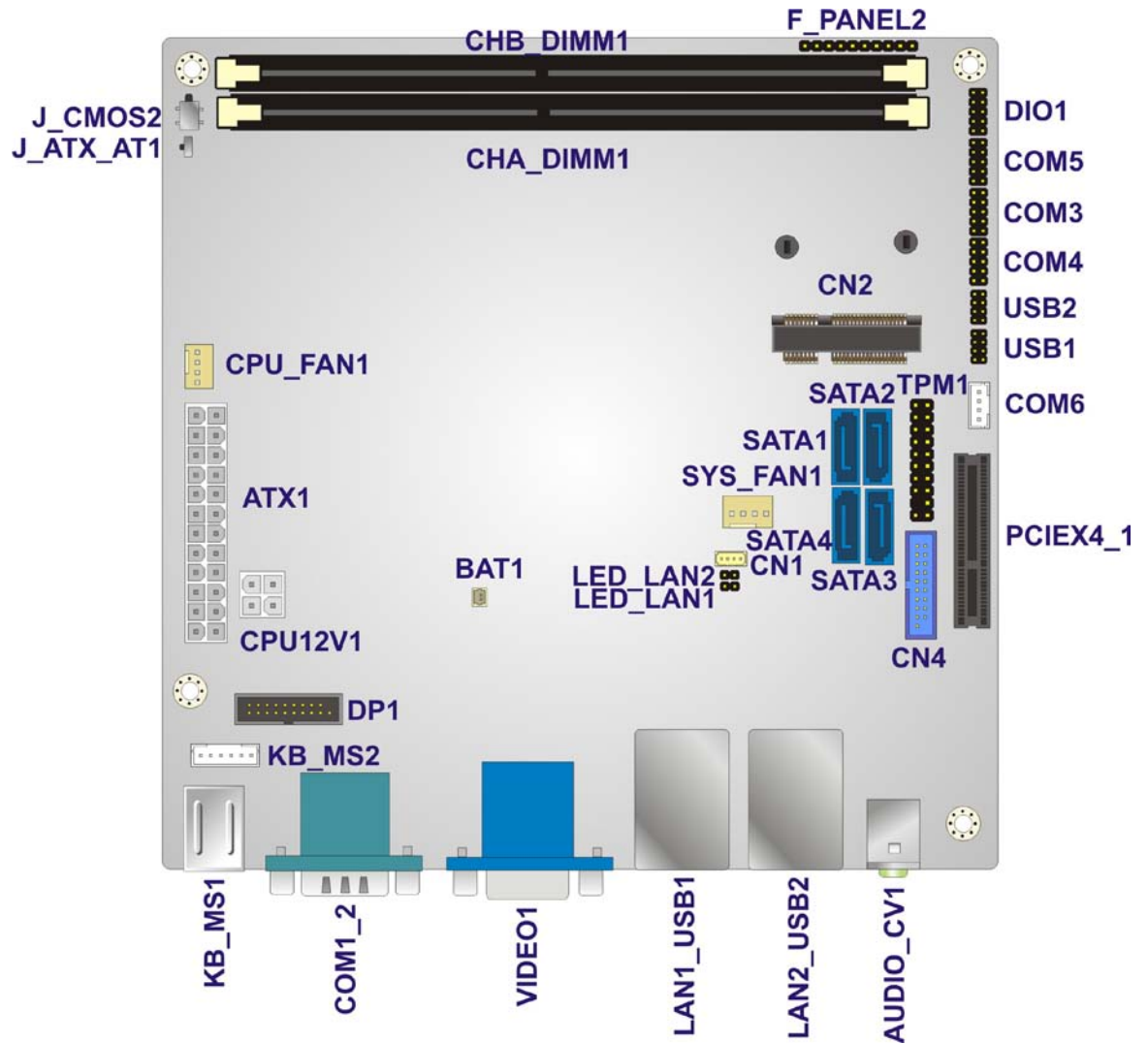

Figure 3-1: Connector and Jumper Locations

3.1.2 Peripheral Interface Connectors

The table below lists all the connectors on the board.

Connector	Type	Label
ATX power connector	24-pin ATX	ATX1
AT/ATX mode select switch	switch	J_ATX_AT1
Battery connector	2-pin wafer	BAT1
Clear CMOS button	button	J_CMOS2
CPU power connector	4-pin Molex	CPU12V1
DDR3 DIMM slots	DDR3 DIMM slot	CHA_DIMM1, CHB_DIMM1
Digital I/O connector	10-pin header	DIO1
Display port connector	20-pin box header	DP1
Fan connector (CPU)	4-pin wafer	CPU_FAN1
Fan connector (System)	4-pin wafer	SYS_FAN1
Front panel connector	10-pin header	F_PANEL2
Keyboard/Mouse connector	6-pin wafer	KB_MS2
LAN LED connector	2-pin header	LED_LAN1, LED_LAN2
PCIe x4 slot	PCIe x4 slot	PCIEX4_1
PCIe Mini card slot	PCIe Mini card slot	CN2
SATA 6Gb/s drive connectors	7-pin SATA connector	SATA1, SATA2, SATA3, SATA4
Serial port, RS-422/485	4-pin wafer	COM6
Serial port, RS-232	10-pin header	COM3, COM4, COM5
SMBus connector	4-pin wafer	CN1
TPM connector	20-pin connector	TPM1

KINO-AQ870

USB connectors	8-pin header, 20-pin box header	USB1, USB2, CN4
----------------	------------------------------------	--------------------

Table 3-1: Peripheral Interface Connectors

3.1.3 External Interface Panel Connectors

The table below lists the connectors on the external I/O panel.

Connector	Type	Label
Audio connector	Audio jack	AUDIO_CV1
Ethernet and USB connector	RJ-45, USB	LAN1_USB1, LAN2_USB2
Keyboard/Mouse	Dual PS/2	KB_MS1
RS-232 serial port connector	DB-9 male	COM1_2
VGA and DVI connector	15-pin female, 24-pin female	VIDEO1

Table 3-2: Rear Panel Connectors

3.2 Internal Peripheral Connectors

The section describes all of the connectors on the KINO-AQ870.

3.2.1 ATX Power Connector

CN Label:	ATX1
CN Type:	24-pin ATX
CN Location:	See Figure 3-2
CN Pinouts:	See Table 3-3

The ATX power connector connects to an ATX power supply.

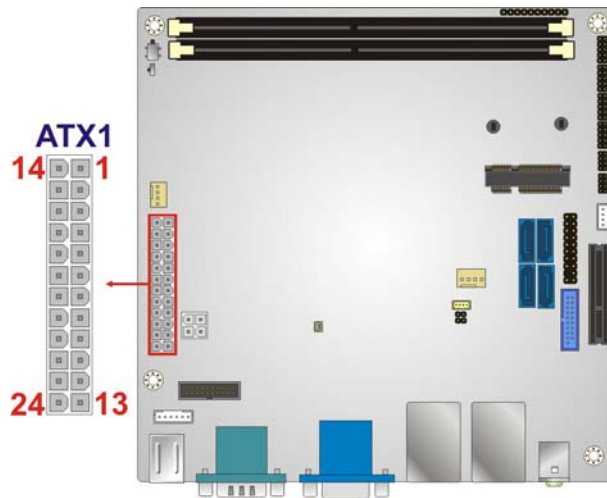

Figure 3-2: ATX Power Connector Location

PIN NO.	DESCRIPTION	PIN NO.	DESCRIPTION
1	+3.3 V	2	+3.3 V
3	GND	4	+5 V
5	GND	6	+5 V
7	GND	8	PWRGD_PS
9	+5VSB	10	+12 V
11	+12 V	12	+3.3 V
13	+3.3 V	14	-12 V
15	GND	16	IO_PSON#
17	GND	18	GND
19	GND	20	N/A
21	+5 V	22	+5 V
23	+5 V	24	GND

Table 3-3: ATX Power Connector Pinouts

3.2.2 AT/ATX Mode Select Switch

CN Label: **J_ATX_AT1**

CN Type: switch

CN Settings: See **Table 3-4**

KINO-AQ870

CN Location: See **Figure 3-3**

The AT/ATX mode select switch specifies the systems power mode as AT or ATX.
AT/ATX mode select switch settings are shown in **Table 3-4**.

Setting	Description	
Short 1-2	AT Mode	
Short 2-3	ATX Mode	Default

Table 3-4: AT/ATX Mode Select Switch Settings

The location of the AT/ATX mode select switch is shown in **Figure 3-3** below.

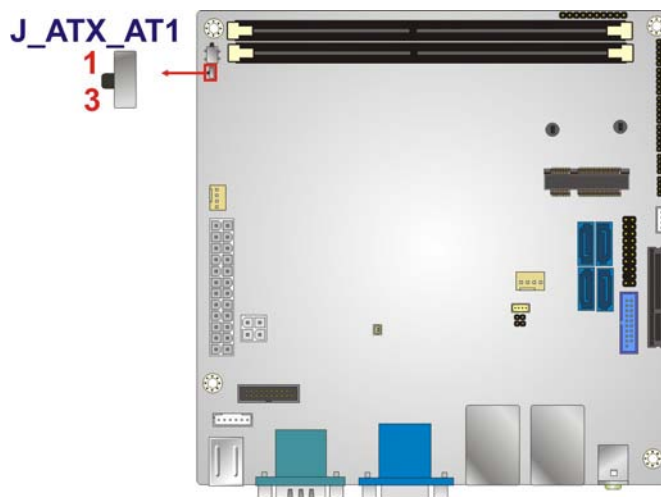

Figure 3-3: AT/ATX Mode Select Switch Location

3.2.3 Battery Connector

CN Label: **BAT1**

CN Type: 2-pin wafer

CN Location: See **Figure 3-4**

CN Pinouts: See **Table 3-5**

The battery connector is connected to the system battery. The battery provides power to the system clock to retain the time when power is turned off.

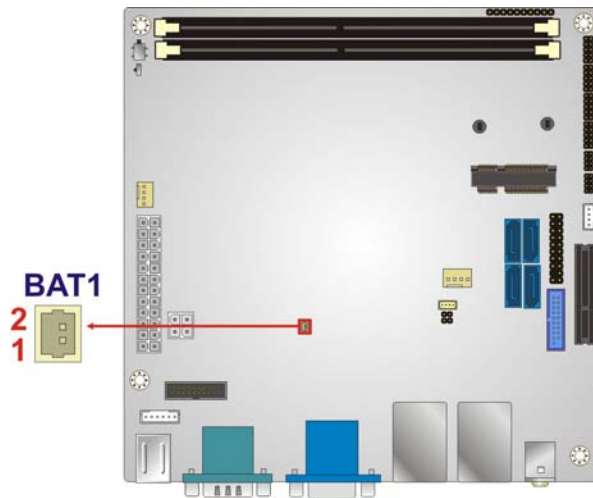

Figure 3-4: Battery Connector Location

PIN NO.	DESCRIPTION	PIN NO.	DESCRIPTION
1	VBATT	2	GND

Table 3-5: Battery Connector Pinouts

3.2.4 Clear CMOS Button

- CN Label: J_CMOS2
- CN Type: button
- CN Settings: See **Table 3-6**
- CN Location: See **Figure 3-5**

If the KINO-AQ870 fails to boot due to improper BIOS settings, use the button to clear the CMOS data and reset the system BIOS information.

The clear CMOS button settings are shown in **Table 3-6**.

Setting	Description	
Open	Normal Operation	Default
Push	Clear CMOS Setup	

Table 3-6: Clear CMOS Button Settings

The location of the clear CMOS button is shown in **Figure 3-5**.

KINO-AQ870



Figure 3-5: Clear CMOS Button Location

3.2.5 CPU Power Connector

- CN Label: CPU12V1
- CN Type: 4-pin Molex
- CN Location: See **Figure 3-6**
- CN Pinouts: See **Table 3-7**

The CPU power connector provides power to the CPU.

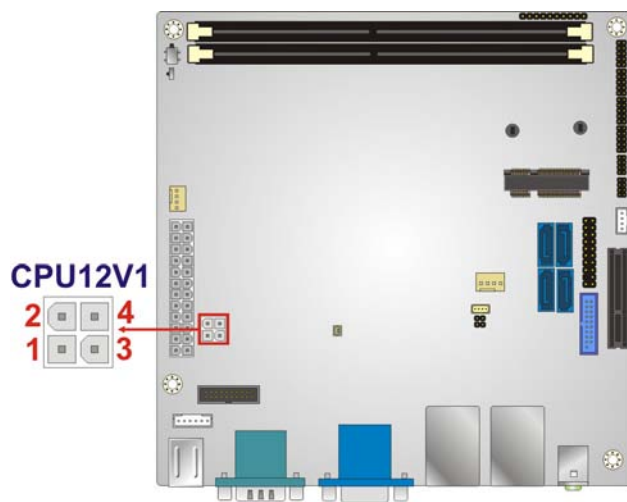

Figure 3-6: CPU Power Connector Location

PIN NO.	DESCRIPTION	PIN NO.	DESCRIPTION
1	GND	2	GND
3	VREG_12V	4	VREG_12V

Table 3-7: CPU Power Connector Pinouts

3.2.6 DDR3 DIMM Slots

CN Label: CHA_DIMM1, CHB_DIMM1

CN Type: DDR3 DIMM slot

CN Location: See **Figure 3-7**

The DIMM slots are for DDR3 DIMM memory modules.

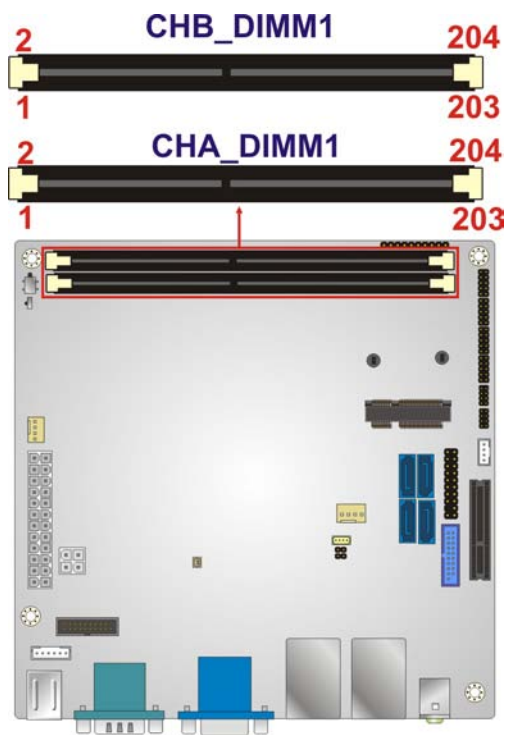

Figure 3-7: DDR3 DIMM Slot Locations

KINO-AQ870

3.2.7 Digital I/O Connector

CN Label:	DIO1
CN Type:	10-pin header
CN Location:	See Figure 3-8
CN Pinouts:	See Table 3-8

The digital I/O connector provides programmable input and output for external devices. The digital I/O provides 4-bit output and 4-bit input.

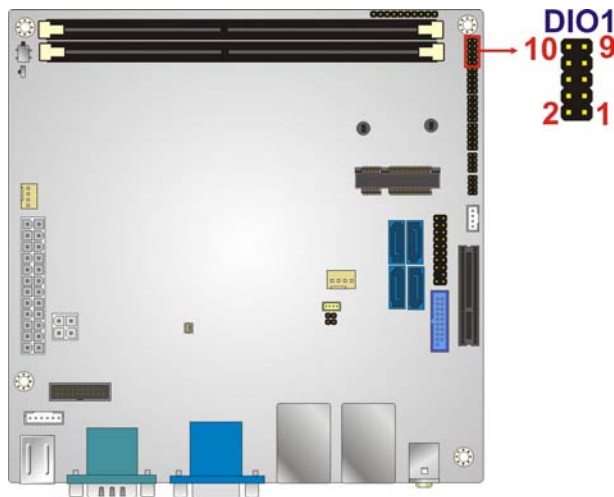

Figure 3-8: Digital I/O Connector Location

PIN NO.	DESCRIPTION	PIN NO.	DESCRIPTION
1	GND	2	+5V
3	DGPO3	4	DGPO2
5	DGPO1	6	DGPO0
7	DGPI3	8	DGPI2
9	DGPI1	10	DGPI0

Table 3-8: Digital I/O Connector Pinouts

3.2.8 Display Port Connector

CN Label:	DP1
-----------	-----

CN Type: 20-pin box header

CN Location: See **Figure 3-9**

CN Pinouts: See **Table 3-9**

The disport port connector provides flexible display function that supports VGA, DVI, LVDS and HDMI via the disport port convert board.

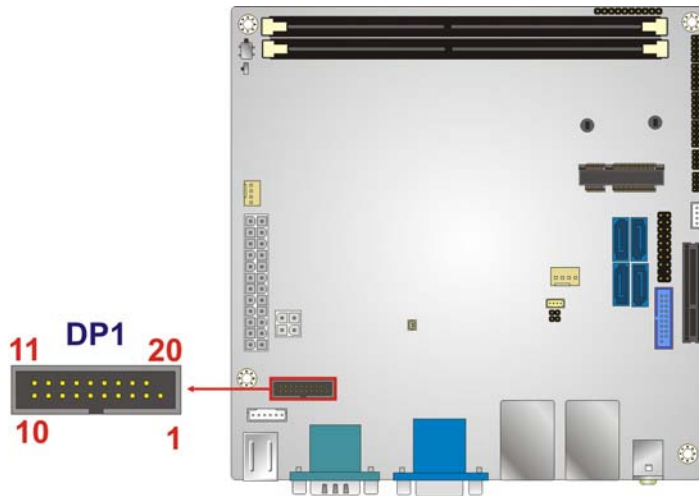

Figure 3-9: Display Port Connector Location

Pin	Description	Pin	Description
1	+5V	2	DPD_OB_LANE1_N
3	DPD_OB_LANE1_P	4	GND
5	DPD_OB_LANE3_N	6	DPD_OB_LANE3_P
7	GND	8	AUX_CTRL_DET_D
9	GND	10	DDI1_HPD#
11	DPD_AUX_CTRL_P2	12	DPD_AUX_CTRL_N2
13	GND	14	DPD_OB_LANE2_P
15	DPD_OB_LANE2_N	16	GND
17	DPD_OB_LANE0_P	18	DPD_OB_LANE0_N
19	+3.3V	20	NC

Table 3-9: Display Port Connector Pinouts

KINO-AQ870

3.2.9 Fan Connector (CPU)

CN Label:	CPU_FAN1
CN Type:	4-pin wafer
CN Location:	See Figure 3-10
CN Pinouts:	See Table 3-10

The fan connector attaches to a CPU cooling fan.

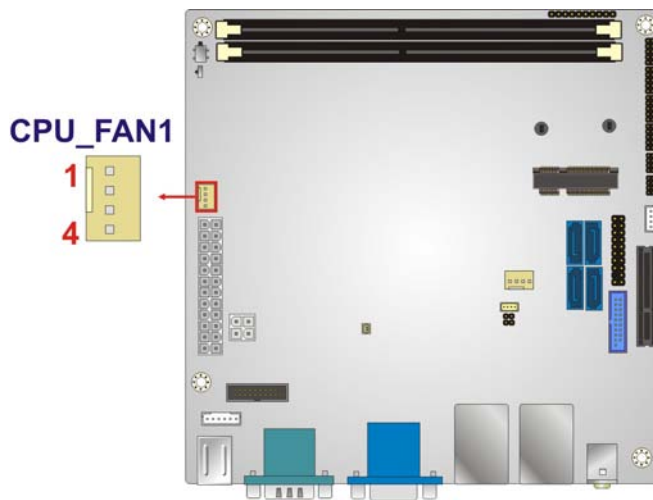

Figure 3-10: CPU Fan Connector Locations

PIN NO.	DESCRIPTION	PIN NO.	DESCRIPTION
1	GND	2	+12V
3	FANIO1	4	FANOUT1

Table 3-10: CPU Fan Connector Pinouts

3.2.10 Fan Connector (System)

CN Label:	SYS_FAN1
CN Type:	4-pin wafer
CN Location:	See Figure 3-11
CN Pinouts:	See Table 3-11

The fan connector connects to a system cooling fan.

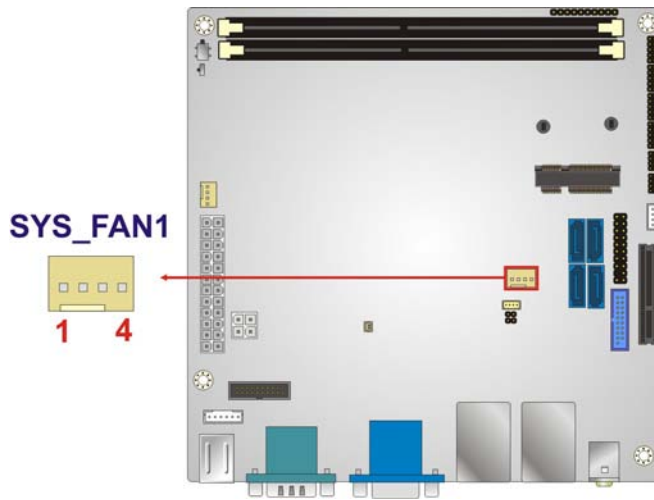

Figure 3-11: System Fan Connector Location

PIN NO.	DESCRIPTION	PIN NO.	DESCRIPTION
1	GND	2	+12V
3	FANIO2	4	FANOUT2

Table 3-11: System Fan Connector Pinouts

3.2.11 Front Panel Connector

- CN Label: F_PANEL2
- CN Type: 10-pin header
- CN Location: See **Figure 3-12**
- CN Pinouts: See **Table 3-12**

The front panel connector connects to the indicator LEDs and buttons on the computer's front panel.

KINO-AQ870

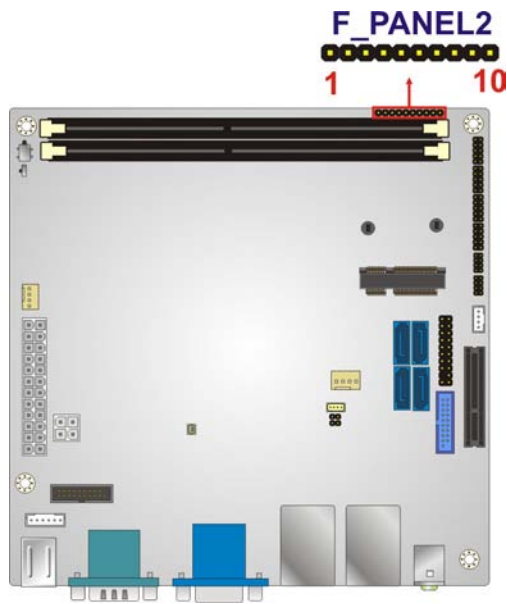

Figure 3-12: Front Panel Connector Location

PIN NO.	DESCRIPTION	PIN NO.	DESCRIPTION
1	NC	2	PWRBTN_SW
3	GND	4	HDDLED+
5	HDDLED-	6	PWRLED+
7	PWRLED+	8	GND
9	EXTRST-	10	GND

Table 3-12: Front Panel Connector Pinouts

3.2.12 Keyboard/Mouse Connector

- CN Label: KB_MS2
- CN Type: 6-pin wafer
- CN Location: See **Figure 3-13**
- CN Pinouts: See **Table 3-13**

The keyboard/mouse connector connects to a PS/2 Y-cable that can be connected to a PS/2 keyboard and mouse.

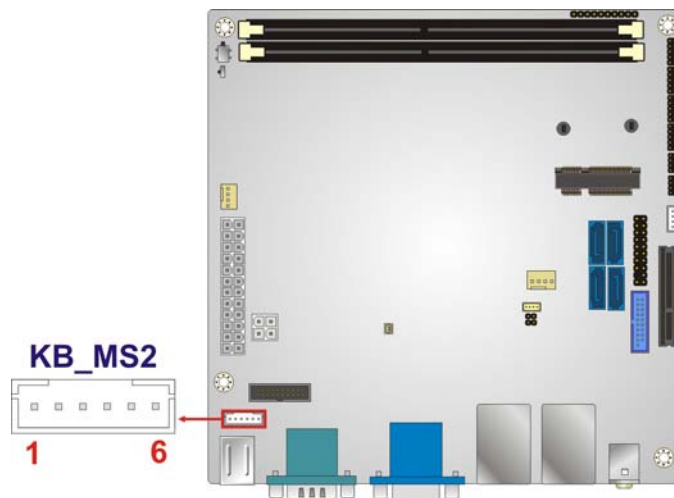

Figure 3-13: Keyboard/Mouse Connector Location

Pin	Description
1	+5V_KBMS
2	MSDATA
3	MSCLK
4	KBDATA
5	KBCLK
6	GND

Table 3-13: Keyboard/Mouse Connector Pinouts

3.2.13 LAN LED Connector

CN Label: LED_LAN1, LED_LAN2

CN Type: 2-pin header

CN Location: See **Figure 3-14**

CN Pinouts: See **Table 3-14**

The LAN LED connectors connect to the LAN link LEDs on the system.

KINO-AQ870

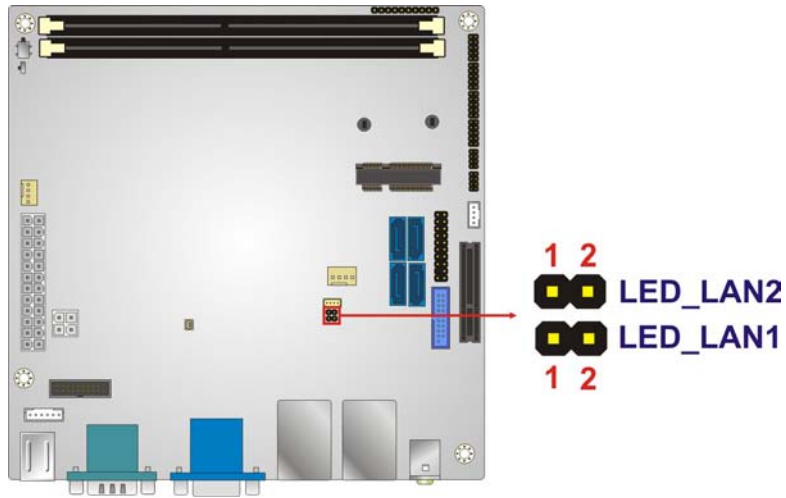

Figure 3-14: LAN LED Connector Location

PIN NO.	DESCRIPTION	PIN NO.	DESCRIPTION
1	+3.3VLAN	2	LAN1/2_LED_LINK#

Table 3-14: LAN LED Connector Pinouts

3.2.14 PCIe x4 Slot

- CN Label: PCIEX4_1
- CN Type: PCIe x4 slot
- CN Location: See **Figure 3-15**

The PCIe x4 slot is for PCIe x4 expansion cards.

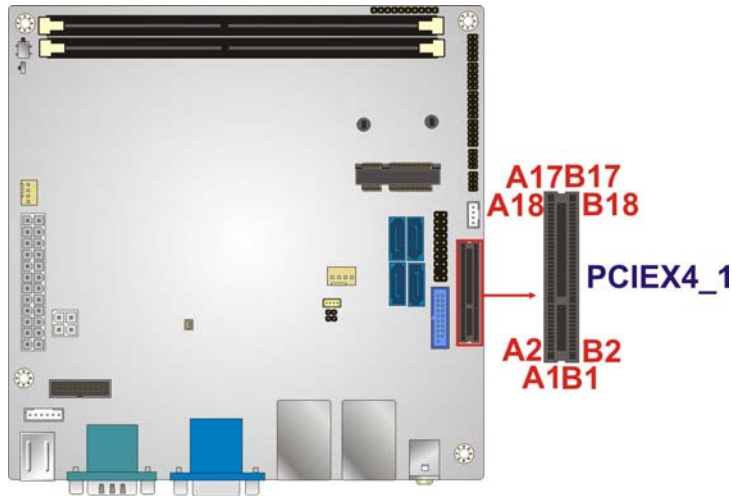

Figure 3-15: PCIe x4 Slot Location

3.2.15 PCIe Mini Card Slot

- CN Label: CN2
- CN Type: PCIe Mini card slot
- CN Location: See **Figure 3-16**

The PCIe Mini card slot is for installing a PCIe Mini expansion card.

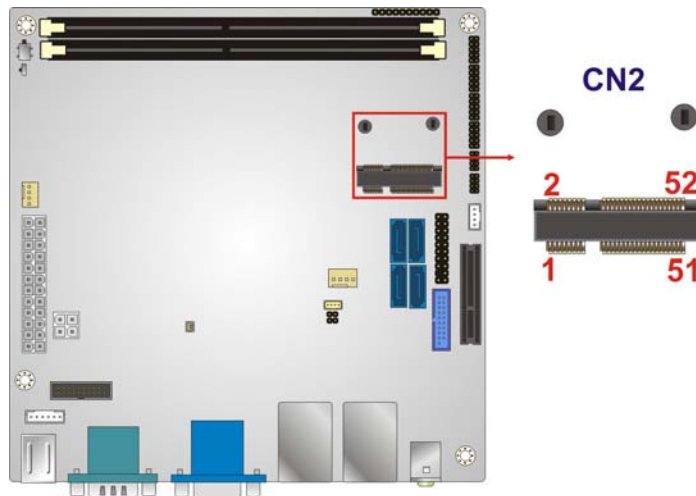

Figure 3-16: PCIe Mini Card Slot Location

KINO-AQ870

3.2.16 SATA 6Gb/s Drive Connectors

CN Label: **SATA1, SATA2, SATA3, SATA4**

CN Type: 7-pin SATA connector

CN Location: See **Figure 3-17**

The four SATA 6Gb/s drive connectors are each connected to a SATA 6Gb/s drive. The SATA 6Gb/s drives transfer data at speeds as high as 6Gb/s.

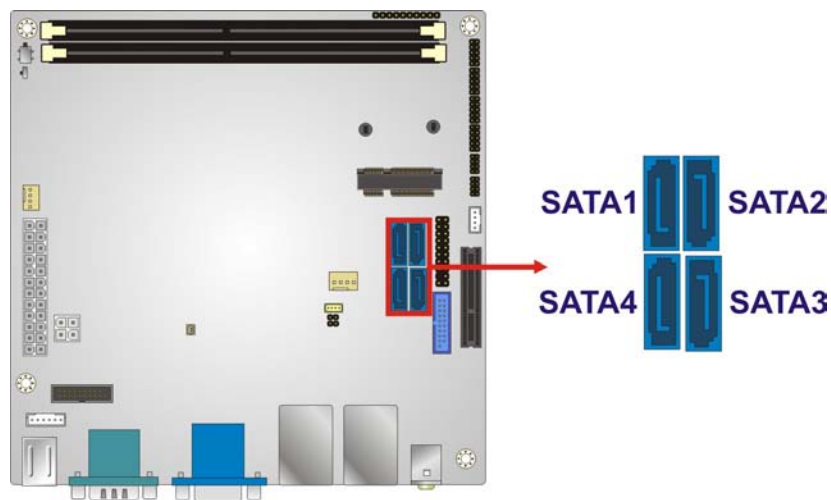

Figure 3-17: SATA 6Gb/s Drive Connector Locations

3.2.17 Serial Port Connector, RS-422/485

CN Label: COM6

CN Type: 4-pin wafer

CN Location: See **Figure 3-18**

CN Pinouts: See **Table 3-15**

This connector provides RS-422 or RS-485 communications.

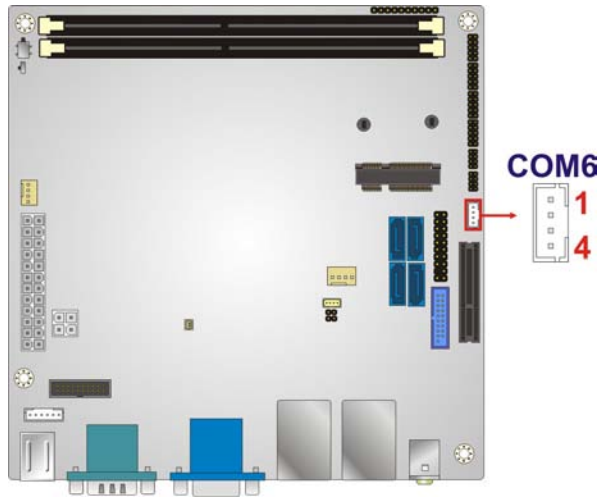

Figure 3-18: RS-422/485 Connector Location

PIN NO.	DESCRIPTION	PIN NO.	DESCRIPTION
1	RXD485#	2	RXD485
3	TXD485	4	TXD485#

Table 3-15: RS-422/485 Connector Pinouts

3.2.18 Serial Port Connectors, RS-232

CN Label: COM3, COM4, COM5

CN Type: 10-pin header

CN Location: See **Figure 3-19**

CN Pinouts: See **Table 3-16**

Each of these connectors provides RS-232 connections.

KINO-AQ870

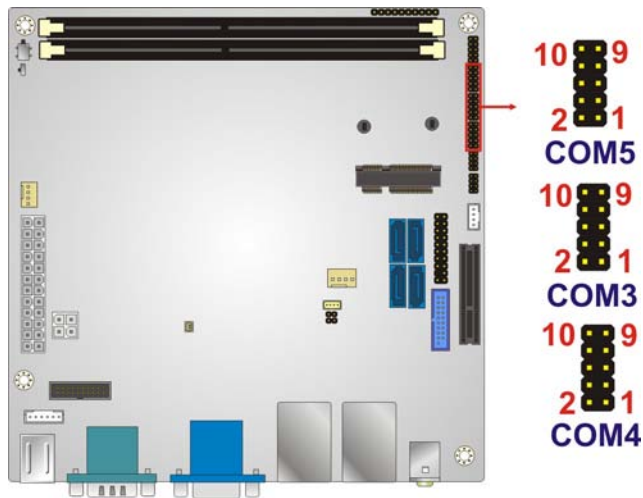

Figure 3-19: Serial Port Connector Location

PIN NO.	DESCRIPTION	PIN NO.	DESCRIPTION
1	DCD#	2	DSR#
3	RXD	4	RTS#
5	TXD	6	CTS#
7	DTR#	8	RI#
9	GND	10	NC

Table 3-16: Serial Port Connector Pinouts

3.2.19 SMBUS Connector

- CN Label: CN1
- CN Type: 4-pin wafer
- CN Location: See **Figure 3-20**
- CN Pinouts: See **Table 3-17**

The SMBus (System Management Bus) connector provides low-speed system management communications.

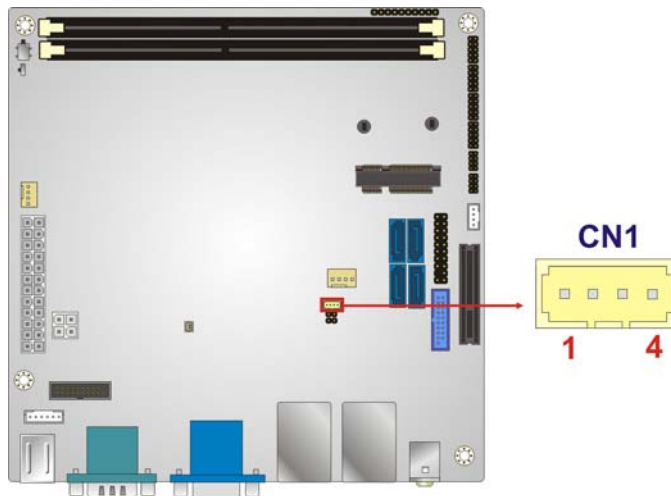

Figure 3-20: SMBus Connector Location

PIN NO.	DESCRIPTION	PIN NO.	DESCRIPTION
1	GND	2	SMBDATA
3	SMBCLK	4	+5V

Table 3-17: SMBus Connector Pinouts

3.2.20 TPM Connector

- CN Label: TPM1
- CN Type: 20-pin connector
- CN Location: See **Figure 3-21**
- CN Pinouts: See **Table 3-18**

The Trusted Platform Module (TPM) connector secures the system on bootup.

KINO-AQ870

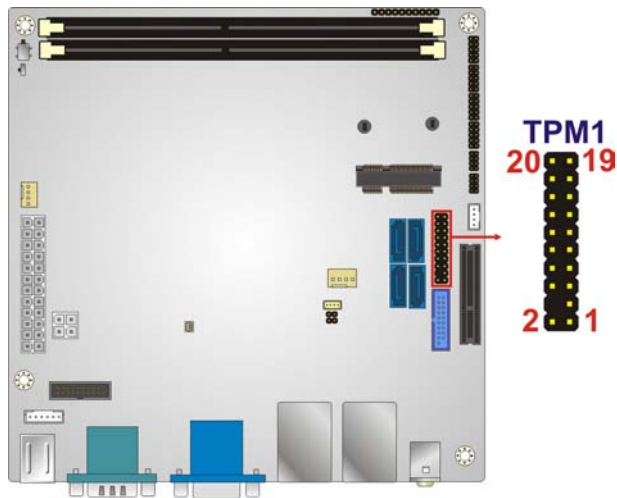

Figure 3-21: TPM Connector Location

PIN NO.	DESCRIPTION	PIN NO.	DESCRIPTION
1	TPMPCLK	2	GND
3	LPC_FRAME#	4	NC
5	BUF_PCIRST#	6	+5V
7	LPC_AD3	8	LPC_AD2
9	+3.3V	10	LPC_AD1
11	LPC_AD0	12	GND
13	SMBCLK_RESUME	14	SMBDATA_RESUME
15	+3V_DUAL	16	SERIRQ
17	GND	18	+3.3V
19	LPCPD_N	20	LDRO0#

Table 3-18: TPM Connector Pinouts

3.2.21 USB Connectors

- CN Label: **USB1, USB2, CN4**
- CN Type: 8-pin header, 20-pin box header
- CN Location: See **Figure 3-22**
- CN Pinouts: See **Table 3-19** and **Table 3-20**

The USB connectors connect to USB devices. Each pin header provides two USB ports.

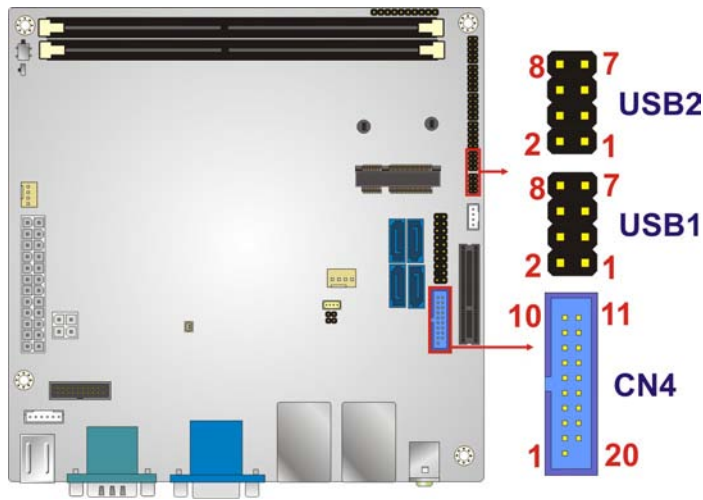

Figure 3-22: USB Connector Locations

PIN NO.	DESCRIPTION	PIN NO.	DESCRIPTION
1	+5V	2	GND
3	USB20_C_N4/8	4	USB20_C_P5/9
5	USB20_C_P4/8	6	USB20_C_N5/9
7	GND	8	+5V

Table 3-19: USB 2.0 Connector Pinouts (USB1, USB2)

PIN NO.	DESCRIPTION	PIN NO.	DESCRIPTION
1	VCC_USB3.0	2	USB3P1_RXDN1
3	USB3P1_RXDP1	4	GND
5	USB3P1_TXDN1	6	USB3P1_TXDP1
7	GND	8	USB2P1_DM1
9	USB2P1_DP1	10	NC
11	USB2P1_DP2	12	USB2P1_DM2
13	GND	14	USB3P1_TXDP2
15	USB3P1_TXDN2	16	GND
17	USB3P1_RXDP2	18	USB3P1_RXDN2
19	VCC_USB3.0	20	NC

Table 3-20: USB 3.0 Connector Pinouts (CN4)

KINO-AQ870

3.3 External Peripheral Interface Connector Panel

Figure 3-23 shows the KINO-AQ870 external peripheral interface connector (EPIC) panel.

The EPIC panel consists of the following:

- 2 x Audio jacks
- 1 x DVI connector
- 2 x Ethernet connectors
- 1 x Keyboard connector
- 1 x Mouse connector
- 2 x RS-232 serial port connectors
- 2 x USB 2.0 connectors
- 2 x USB 3.0 connectors
- 1 x VGA connector

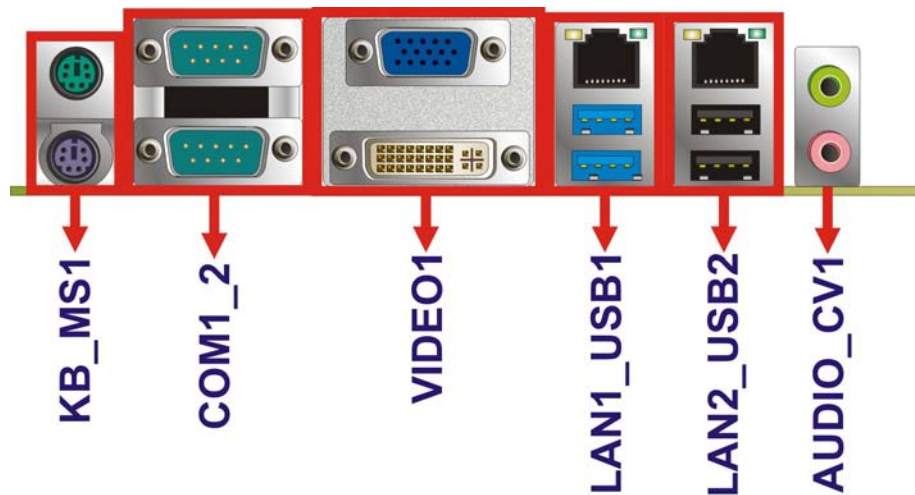

Figure 3-23: KINO-AQ870 External Peripheral Interface Connector

3.3.1 Audio Connector

CN Label:	AUDIO_CV1
CN Type:	Audio jack
CN Location:	See Figure 3-23

The audio jacks connect to external audio devices.

- Line Out port (Lime): Connects to a headphone or a speaker. With multi-channel configurations, this port can also connect to front speakers.
- Microphone (Pink): Connects to a microphone.



Figure 3-24: Audio Connector

3.3.2 Ethernet and USB Connectors

- CN Label: **LAN1_USB1, LAN2_USB2**
- CN Type: RJ-45 , USB 3.0 and USB 2.0 ports
- CN Location: See **Figure 3-23**
- CN Pinouts: See **Figure 3-25 , Table 3-15 and Table 3-22**

The LAN connector connects to a local network.

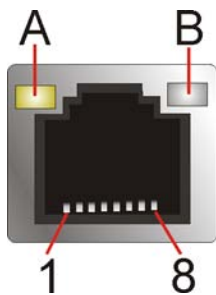

Figure 3-25: LAN Connector

The USB 2.0 ports are for attaching USB 2.0 peripheral devices to the system. The pinouts of LAN1 and USB 2.0 connectors are shown below.

PIN NO.	DESCRIPTION	PIN NO.	DESCRIPTION
P1	+1.5V_LAN2	P2	LAN2_MDIP0
P3	LAN2_MDINO	P4	LAN2_MDIP1

KINO-AQ870

P5	LAN2_MDIN1	P6	LAN2_MDIP2
P7	LAN2_MDN2	P8	LAN2_MDIP3
P9	LAN2_MDIN3	P10	GND
P11	LAN2_LINK100	P12	LAN2_LINK1000
P13	LAN2_ACT-1	P14	+V3.3A_LAN2
U1	+USB_PWR1	U2	USB20_C_N10
U3	USB20_C_P10	U4	GND
U5	+USB_PWR1	U6	USB20_C_N11
U7	USB20_C_P11	U8	GND

Table 3-21: LAN2_USB2 Connector Pinouts

The USB 3.0 ports are for attaching USB 3.0 peripheral devices to the system. To be able to use the USB 3.0 ports, please make sure the USB 3.0 function is enabled in BIOS (see **Section 5.3.7**). The pinouts of LAN2 and USB 3.0 connectors are shown below.

PIN NO.	DESCRIPTION	PIN NO.	DESCRIPTION
1	USB3_PWR1	2	USB2P0_DM1
3	USB2P0_DP1	4	GND
5	USB3P0_RXDN1	6	USB3P0_RXDP1
7	GND	8	USB3P0_TXDN1
9	USB3P0_TXDP1	10	USB3_PWR2
11	USB2P0_DM2	12	USB2P0_DP2
13	GND	14	USB3P0_RXDN2
15	USB3P0_RXDP2	16	GND
17	USB3P0_TXDN2	18	USB3P0_TXDP2
19	+0.9V_LAN1	20	LAN1_MDIP0
21	LAN1_MDIN0	22	LAN1_MDIP1
23	LAN1_MDIN1	24	LAN1_MDIP2
25	LAN1_MDIN2	26	LAN1_MDIP3
27	LAN1_MDIN3	28	GND
29	+3.3V_LAN1	30	LAN1_LINK_ACT#
31	LAN1_100#	32	LAN1_1000#

Table 3-22: LAN1_USB1 Connector Pinouts

3.3.3 Keyboard/Mouse Connector

- CN Label:** **KB_MS1**
- CN Type:** Dual PS/2
- CN Location:** See **Figure 3-23**
- CN Pinouts:** See **Table 3-23**

The PS/2 ports are for connecting a PS/2 mouse and a PS/2 keyboard.

PIN NO.	DESCRIPTION	PIN NO.	DESCRIPTION
A1	KBDATA	A2	N/A
A3	GND	A4	+5V_KBMS
A5	KBCLK	A6	N/A
B1	MSDATA	B2	N/A
B3	GND	B4	+5V_KBMS
B5	MSCLK	B6	N/A

Table 3-23: PS/2 Connector Pinouts

3.3.4 RS-232 Serial Port Connectors

- CN Label:** **COM1_2**
- CN Type:** DB-9 Male
- CN Location:** See **Figure 3-23**
- CN Pinouts:** See **Figure 3-26** and **Table 3-24**

The serial port connects to a RS-232 serial communications device.

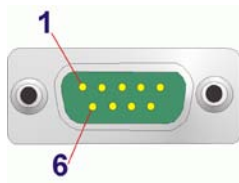

Figure 3-26: RS-232 Serial Port Connector

KINO-AQ870

PIN NO.	DESCRIPTION	PIN NO.	DESCRIPTION
1	NDCD1#	2	NRXD1
3	NTXD1	4	NDTR1#
5	GND	6	NDSR1#
7	NRTS1#	8	NCTS1#
9	NRI1#	10	NDCD2#
11	NRXD2	12	NTXD2
13	NDTR2#	14	GND
15	NDSR2#	16	NRTS2#
17	NCTS2#	18	NRI2#

Table 3-24: RS-232 Serial Port Connector Pinouts

3.3.5 VGA and DVI Connector

CN Label: VIDEO1

CN Type: 15-pin female (VGA) , 24-pin female (DVI)

CN Location: See **Figure 3-23**

CN Pinouts: See **Figure 3-27** , **Table 3-25** and **Table 3-26**

The VGA port connects to a monitor that accepts a standard VGA input.

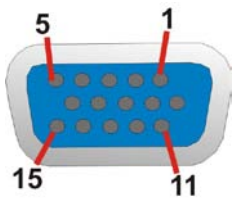

Figure 3-27: VGA Connector

PIN	DESCRIPTION	PIN	DESCRIPTION
1	Red	2	Green
3	Blue	4	NC
5	GND	6	GND
7	GND	8	GND
9	VGAVCC	10	HOTPLUG

PIN	DESCRIPTION	PIN	DESCRIPTION
11	NC	12	DDCDAT
13	HSYNC	14	VSYNC
15	DDCCLK		

Table 3-25: VGA Connector Pinouts

The DVI (Digital Visual Interface) port connects to a monitor that supports DVI video input.

PIN NO.	DESCRIPTION	PIN NO.	DESCRIPTION
1	DVI_TMDS_C_DATA2#	2	DVI_TMDS_C_DATA2
3	GND	4	NC
5	NC	6	DVI_DDC_SCLK
7	DVI_DDC_SDATA	8	NC
9	DVI_TMDS_C_DATA1#	10	DVI_TMDS_C_DATA1
11	GND	12	NC
13	NC	14	+5V_DVI
15	GND	16	DVI_HPD
17	DVI_TMDS_C_DATA0#	18	DVI_TMDS_C_DATA0
19	GND	20	NC
21	NC	22	GND
23	DVI_TMDS_C_CLK	24	DVI_TMDS_C_CLK#
C1	NC	C2	NC
C3	NC	C4	NC

Table 3-26: DVI Connector Pinouts

Chapter

4

Installation

4.1 Anti-static Precautions



WARNING:

Failure to take ESD precautions during the installation of the KINO-AQ870 may result in permanent damage to the KINO-AQ870 and severe injury to the user.

Electrostatic discharge (ESD) can cause serious damage to electronic components, including the KINO-AQ870. Dry climates are especially susceptible to ESD. It is therefore critical that whenever the KINO-AQ870 or any other electrical component is handled, the following anti-static precautions are strictly adhered to.

- ***Wear an anti-static wristband:*** Wearing a simple anti-static wristband can help to prevent ESD from damaging the board.
- ***Self-grounding:*** Before handling the board, touch any grounded conducting material. During the time the board is handled, frequently touch any conducting materials that are connected to the ground.
- ***Use an anti-static pad:*** When configuring the KINO-AQ870, place it on an anti-static pad. This reduces the possibility of ESD damaging the KINO-AQ870.
- ***Only handle the edges of the PCB:*** When handling the PCB, hold the PCB by the edges.

KINO-AQ870

4.2 Installation Considerations



NOTE:

The following installation notices and installation considerations should be read and understood before the KINO-AQ870 is installed. All installation notices pertaining to the installation of the KINO-AQ870 should be strictly adhered to. Failing to adhere to these precautions may lead to severe damage of the KINO-AQ870 and injury to the person installing the motherboard.



WARNING:

The installation instructions described in this manual should be carefully followed in order to prevent damage to the KINO-AQ870, KINO-AQ870 components and injury to the user.

Before and during the installation please **DO** the following:

- Read the user manual:
 - The user manual provides a complete description of the KINO-AQ870 installation instructions and configuration options.
- Wear an electrostatic discharge cuff (ESD):
 - Electronic components are easily damaged by ESD. Wearing an ESD cuff removes ESD from the body and helps prevent ESD damage.
- Place the KINO-AQ870 on an antistatic pad:
 - When installing or configuring the motherboard, place it on an antistatic pad. This helps to prevent potential ESD damage.
- Turn all power to the KINO-AQ870 off:
 - When working with the KINO-AQ870, make sure that it is disconnected from all power supplies and that no electricity is being fed into the system.

Before and during the installation of the KINO-AQ870 **DO NOT:**

- Remove any of the stickers on the PCB board. These stickers are required for warranty validation.
- Use the product before verifying all the cables and power connectors are properly connected.
- Allow screws to come in contact with the PCB circuit, connector pins, or its components.

4.3 Basic Installation



WARNING:

A CPU should never be turned on without the specified cooling kit being installed. If the cooling kit (heat sink and fan) is not properly installed and the system turned on, permanent damage to the CPU, KINO-AQ870 and other electronic components attached to the system may be incurred. Running a CPU without a cooling kit may also result in injury to the user.

The CPU, CPU cooling kit and DIMM are the most critical components of the KINO-AQ870. If one of these component is not installed the KINO-AQ870 cannot run.

4.3.1 Socket LGA1150 CPU Installation



WARNING:

CPUs are expensive and sensitive components. When installing the CPU please be careful not to damage it in anyway. Make sure the CPU is installed properly and ensure the correct cooling kit is properly installed.

Do NOT touch the pins at the bottom of the CPU. When handling the CPU, only hold it on the sides.

KINO-AQ870

To install the CPU, follow the steps below.

Step 1: **Disengage the load lever** by pressing the lever down and slightly outwards to clear the retention tab. Fully open the lever. See **Figure 4-1**.

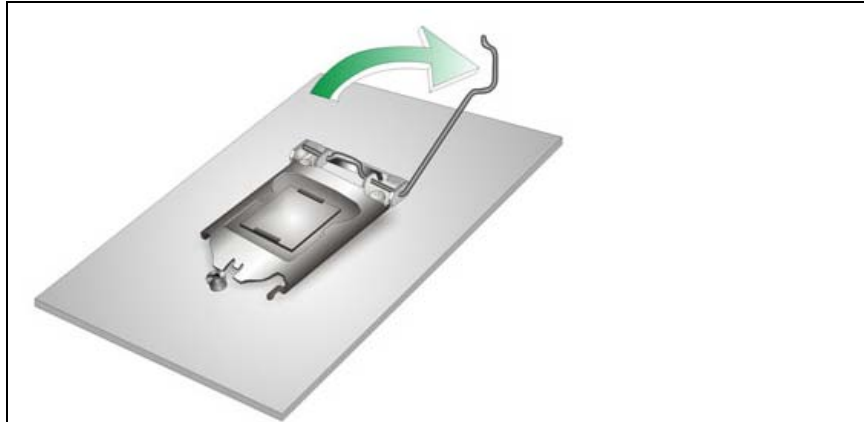

Figure 4-1: Disengage the CPU Socket Load Lever

Step 2: **Open the socket and remove the protective cover.** The black protective cover can be removed by pulling up on the tab labeled "Remove". See **Figure 4-2**.

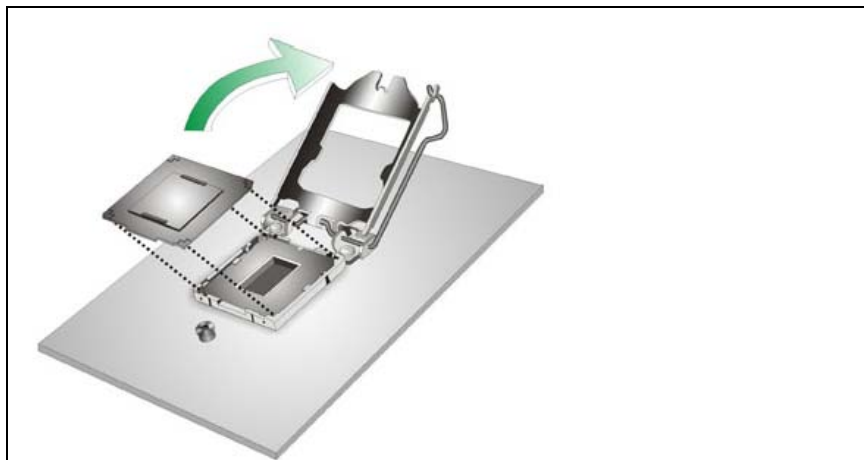

Figure 4-2: Remove Protective Cover

Step 3: **Inspect the CPU socket.** Make sure there are no bent pins and make sure the socket contacts are free of foreign material. If any debris is found, remove it with compressed air.

- Step 4: Orientate the CPU properly.** The contact array should be facing the CPU socket.
- Step 5: Correctly position the CPU.** Match the Pin 1 mark with the CPU edge on the CPU socket.
- Step 6: Align the CPU pins.** Locate pin 1 and the two orientation notches on the CPU. Carefully match the two orientation notches on the CPU with the socket alignment keys.
- Step 7: Insert the CPU.** Gently insert the CPU into the socket. If the CPU pins are properly aligned, the CPU should slide into the CPU socket smoothly. See **Figure 4-3**.

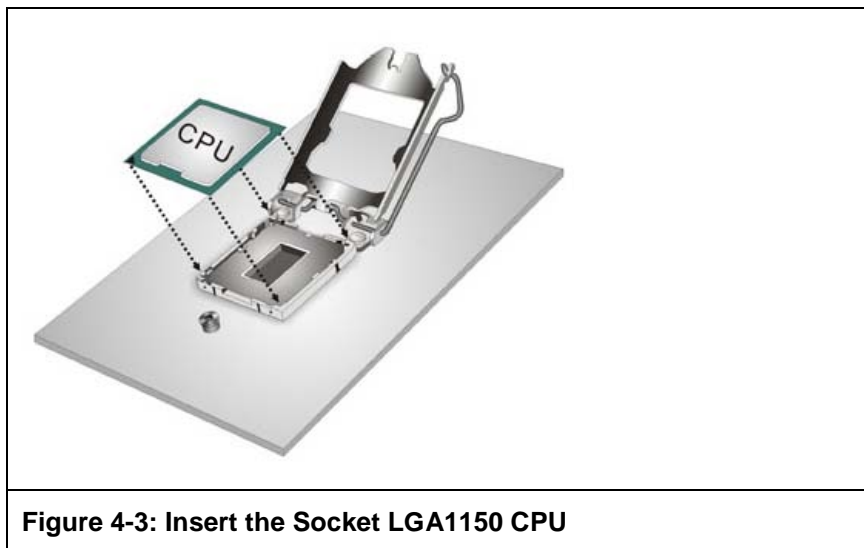

Figure 4-3: Insert the Socket LGA1150 CPU

- Step 8: Close the CPU socket.** Close the load plate and pull the load back a little to have the load plate be able to secure to the knob. Engage the load lever by pushing it back to its original position. See **Figure 4-4**. There will be some resistance, but will not require extreme pressure.

KINO-AQ870

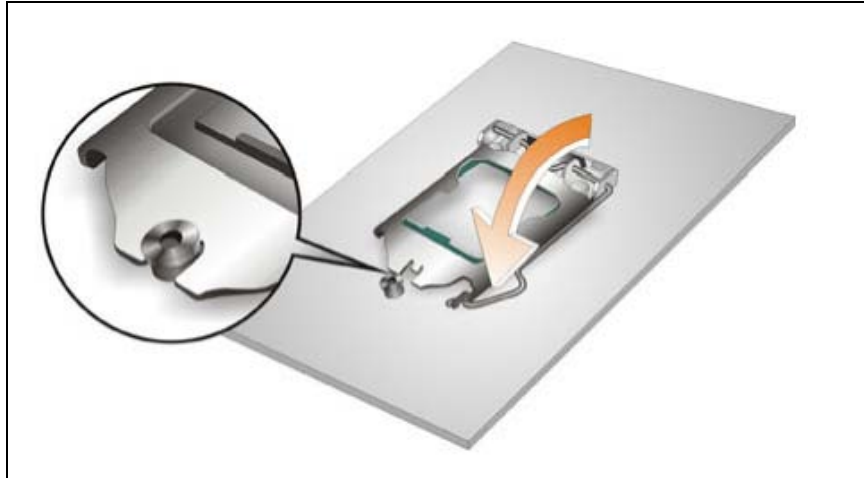

Figure 4-4: Close the Socket LGA1150

Step 9: **Connect the 12 V power to the board.** Connect the 12 V power from the power supply to the board.

4.3.2 Cooling Kit Installation



WARNING:

DO NOT attempt to install a push-pin cooling fan.

The pre-installed support bracket prevents the board from bending and is ONLY compatible with captive screw type cooling fans.

The cooling kits can be bought from IEI. The cooling kit has a heat sink and fan.



WARNING:

Do not wipe off (accidentally or otherwise) the pre-sprayed layer of thermal paste on the bottom of the heat sink. The thermal paste between the CPU and the heat sink is important for optimum heat dissipation.

To install the cooling kit, follow the instructions below.

Step 1: A cooling kit bracket is pre-installed on the rear of the motherboard. See **Figure 4-5**.

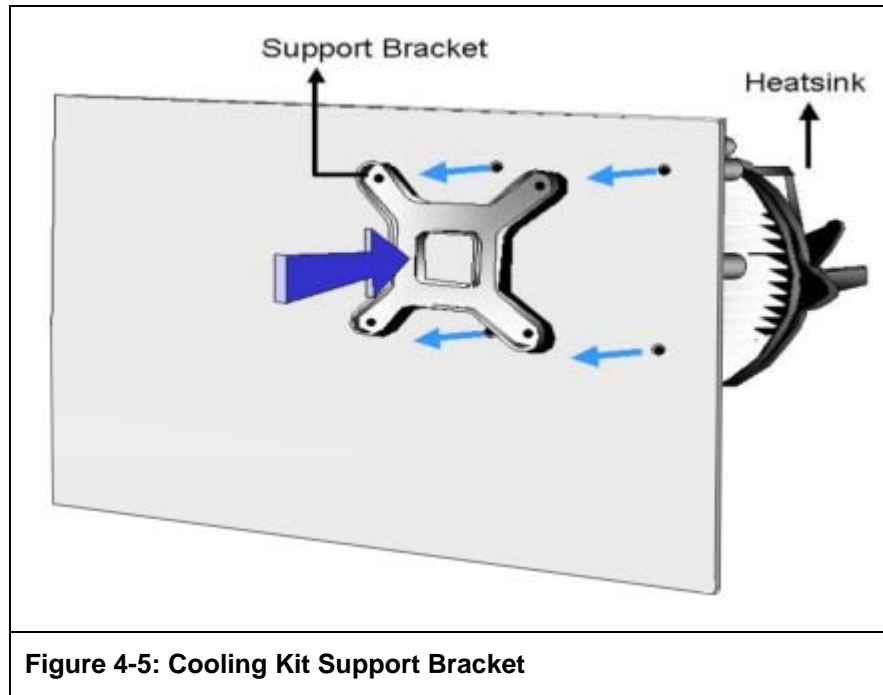

Figure 4-5: Cooling Kit Support Bracket

Step 2: Place the cooling kit onto the socket LGA1150 CPU. Make sure the CPU cable can be properly routed when the cooling kit is installed.

Step 3: Mount the cooling kit. Gently place the cooling kit on top of the CPU. Make sure the four threaded screws on the corners of the cooling kit properly pass through the holes of the cooling kit bracket.

Step 4: Secure the cooling kit by fastening the four retention screw of the cooling kit.

Step 5: Connect the fan cable. Connect the cooling kit fan cable to the fan connector on the KINO-AQ870. Carefully route the cable and avoid heat generating chips and fan blades.

4.3.3 DIMM Installation

To install a DIMM, please follow the steps below and refer to **Figure 4-6**.

KINO-AQ870

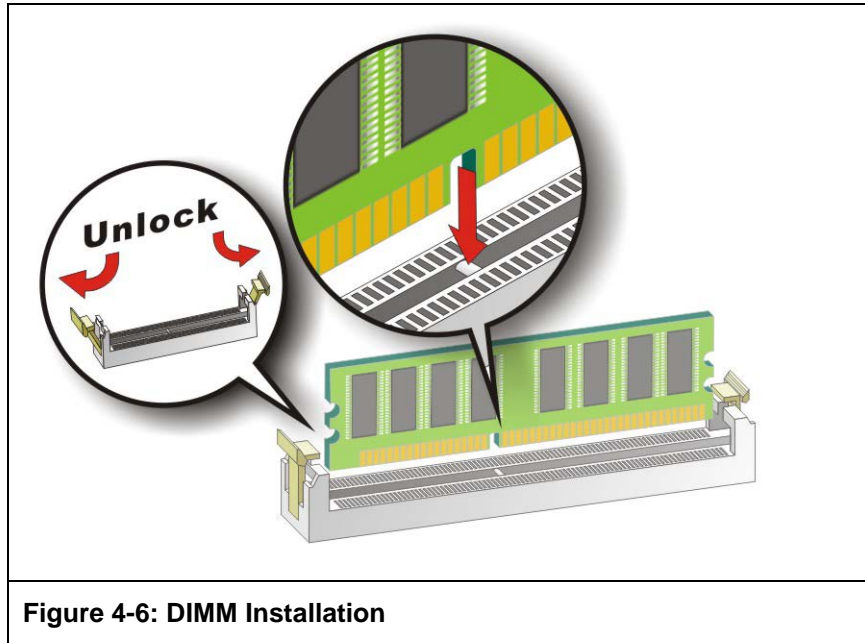

Figure 4-6: DIMM Installation

- Step 1:** Open the DIMM socket handles. Open the two handles outwards as far as they can. See **Figure 4-6**.
- Step 2:** **Align the DIMM with the socket.** Align the DIMM so the notch on the memory lines up with the notch on the memory socket. See **Figure 4-6**.
- Step 3:** **Insert the DIMM.** Once aligned, press down until the DIMM is properly seated. Clip the two handles into place. See **Figure 4-6**.
- Step 4:** **Remove a DIMM.** To remove a DIMM, push both handles outwards. The memory module is ejected by a mechanism in the socket.

4.4 Internal Peripheral Device Connections

This section outlines the installation of peripheral devices to the on-board connectors

4.4.1 SATA Drive Connection

The KINO-AQ870 is shipped with two SATA drive cables and one SATA drive power cable. To connect the SATA drives to the connectors, please follow the steps below.

Step 1: Locate the connectors. The locations of the SATA drive connectors are shown in **Chapter 3**.

Step 2: Insert the cable connector. Press the clip on the connector at the end of the SATA cable and insert the cable connector into the on-board SATA drive connector. See **Figure 4-7**.

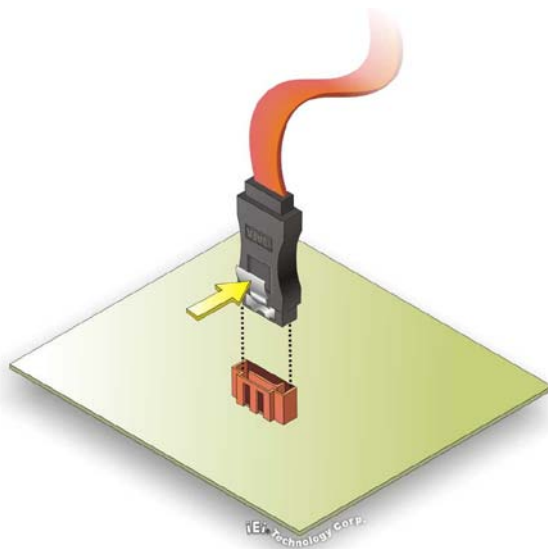

Figure 4-7: SATA Drive Cable Connection

Step 3: Connect the cable to the SATA disk. Connect the connector on the other end of the cable to the connector at the back of the SATA drive. See **Figure 4-8**.

Step 4: Connect the SATA power cable. Connect the SATA power connector to the back of the SATA drive. See **Figure 4-8**.

KINO-AQ870

Figure 4-8: SATA Power Drive Connection

4.5 External Peripheral Interface Connection

The following external peripheral devices can be connected to the external peripheral interface connectors.

- Audio devices
- DVI devices
- PS/2 keyboard and mouse connector
- RJ-45 Ethernet cable connector
- Serial port devices
- USB devices
- VGA monitor

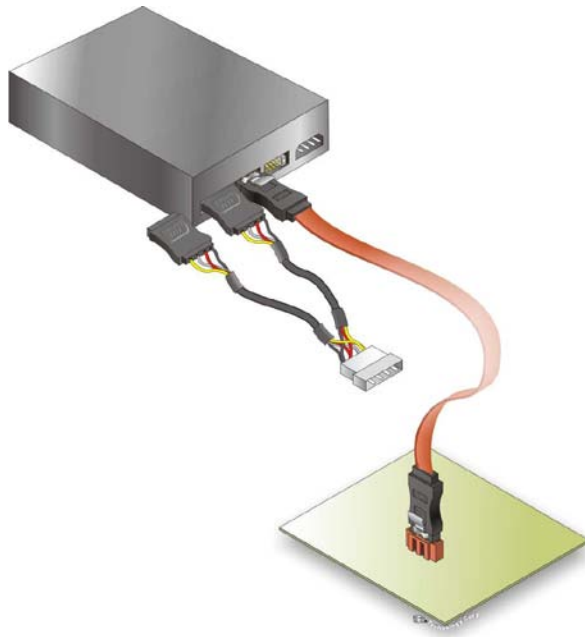
To install these devices, connect the corresponding cable connector from the actual device to the corresponding KINO-AQ870 external peripheral interface connector making sure the pins are properly aligned.

4.5.1 Audio Connection

The audio jacks on the external audio connector enable the KINO-AQ870 to be connected to a stereo sound setup. To install the audio devices, follow the steps below.

- Step 1: Identify the audio plugs.** The plugs on your home theater system or speakers may not match the colors on the rear panel. If audio plugs are plugged into the wrong jacks, sound quality will be very bad.
- Step 2: Plug the audio plugs into the audio jacks.** Plug the audio plugs into the audio jacks. If the plugs on your speakers are different, an adapter will need to be used to plug them into the audio jacks.
- **Line Out port (Lime):** Connects to a headphone or a speaker.
 - **Microphone (Pink):** Connects to a microphone.

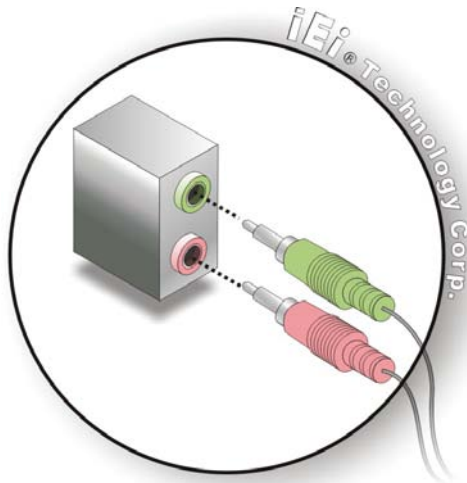

Figure 4-9: Audio Connector

- Step 3: Check audio clarity.** Check that the sound is coming through the right speakers by adjusting the balance front to rear and left to right.

4.5.2 DVI Display Device Connection

The KINO-AQ870 has a single female DVI connector on the external peripheral interface panel. The DVI connector is connected to a digital display device. To connect a digital display device to the KINO-AQ870, please follow the instructions below.

KINO-AQ870

- Step 1: Locate the DVI connector.** The location of the DVI connector is shown in **Chapter 3**.
- Step 2: Align the DVI connector.** Align the male DVI connector on the digital display device cable with the female DVI connector on the external peripheral interface.
- Step 3: Insert the DVI connector.** Once the connectors are properly aligned with the male connector, insert the male connector from the digital display device into the female connector on the KINO-AQ870. See **Figure 4-10**.

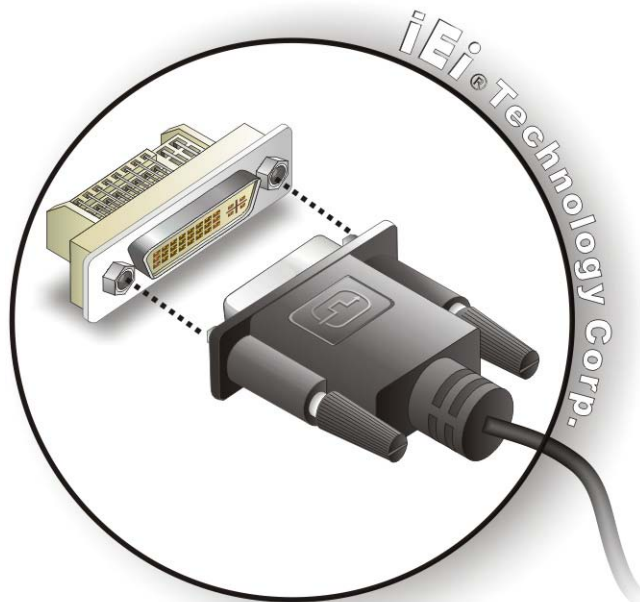

Figure 4-10: DVI Connector

- Step 4: Secure the connector.** Secure the DVI connector from the digital display device to the external interface by tightening the two retention screws on either side of the connector.

4.5.3 LAN Connection

There are two external RJ-45 LAN connectors. The RJ-45 connector enables connection to an external network. To connect a LAN cable with an RJ-45 connector, please follow the instructions below.

Step 1: Locate the RJ-45 connectors. The locations of the LAN connectors are shown in **Chapter 3**.

Step 2: Align the connectors. Align the RJ-45 connector on the LAN cable with one of the RJ-45 connectors on the KINO-AQ870. See **Figure 4-11**.

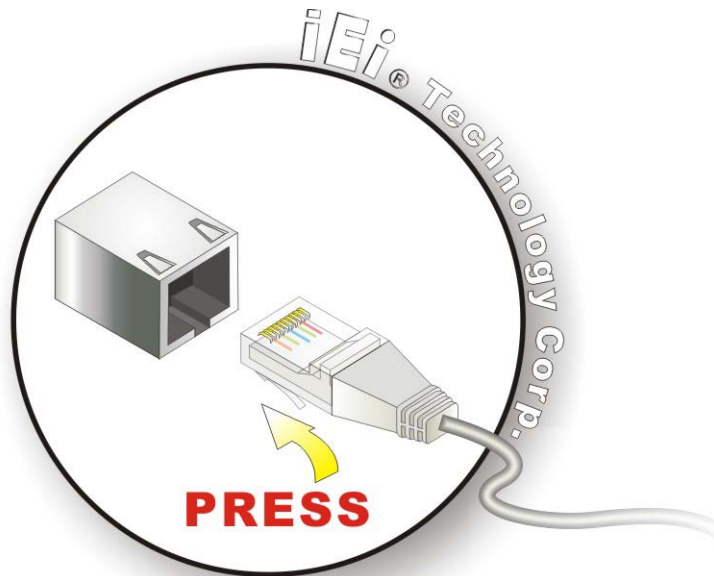

Figure 4-11: LAN Connection

Step 3: Insert the LAN cable RJ-45 connector. Once aligned, gently insert the LAN cable RJ-45 connector into the on-board RJ-45 connector.

4.5.4 PS/2 Keyboard and Mouse Connection

The KINO-AQ870 has a dual PS/2 connector on the external peripheral interface panel. The dual PS/2 connector is used to connect to a keyboard and mouse to the system. Follow the steps below to connect a keyboard and mouse to the KINO-AQ870.

Step 1: Locate the dual PS/2 connector. The location of the dual PS/2 connector is shown in **Chapter 3**.

Step 2: Insert the keyboard/mouse connector. Insert a PS/2 keyboard or mouse connector into the appropriate PS/2 connector on the external peripheral interface connector. See **Figure 4-12**.

KINO-AQ870

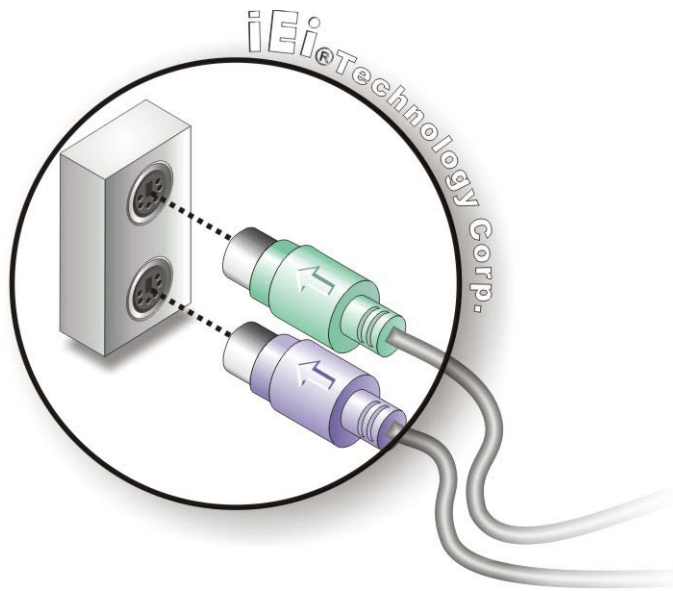

Figure 4-12: PS/2 Keyboard/Mouse Connector

4.5.5 Serial Device Connection

The KINO-AQ870 has two single female DB-9 connectors on the external peripheral interface panel for a serial device. Follow the steps below to connect a serial device to the KINO-AQ870.

- Step 1:** **Locate the DB-9 connector.** The locations of the DB-9 connectors are shown in **Chapter 3**.
- Step 2:** **Insert the serial connector.** Insert the DB-9 connector of a serial device into the DB-9 connector on the external peripheral interface. See **Figure 4-13**.

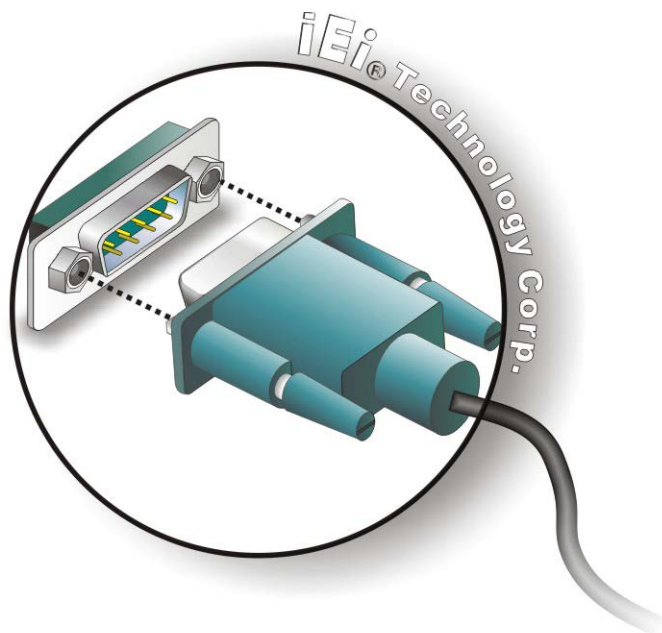

Figure 4-13: Serial Device Connector

Step 3: Secure the connector. Secure the serial device connector to the external interface by tightening the two retention screws on either side of the connector

4.5.6 USB Connection

The external USB Series "A" receptacle connectors provide easier and quicker access to external USB devices. Follow the steps below to connect USB devices to the KINO-AQ870.

Step 1: Locate the USB Series "A" receptacle connectors. The locations of the USB Series "A" receptacle connectors are shown in **Chapter 3**.

Step 2: Insert a USB Series "A" plug. Insert the USB Series "A" plug of a device into the USB Series "A" receptacle on the external peripheral interface. See **Figure 4-14**.

KINO-AQ870

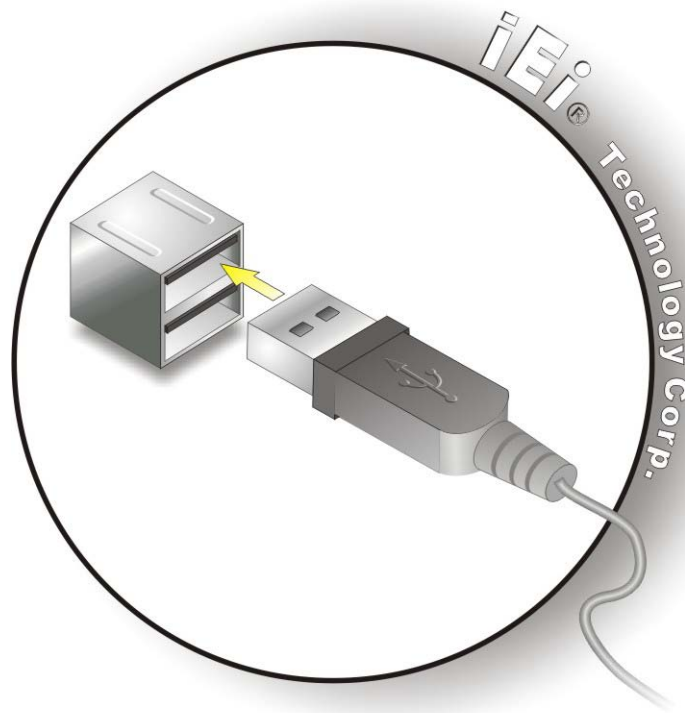

Figure 4-14: USB Connector

4.5.7 VGA Monitor Connection

The KINO-AQ870 has a single female DB-15 connector on the external peripheral interface panel. The DB-15 connector is connected to a CRT or VGA monitor. To connect a monitor to the KINO-AQ870, please follow the instructions below.

- Step 1: Locate the female DB-15 connector.** The location of the female DB-15 connector is shown in **Chapter 3**.
- Step 2: Align the VGA connector.** Align the male DB-15 connector on the VGA screen cable with the female DB-15 connector on the external peripheral interface.
- Step 3: Insert the VGA connector.** Once the connectors are properly aligned with the insert the male connector from the VGA screen into the female connector on the KINO-AQ870. See **Figure 4-15**.

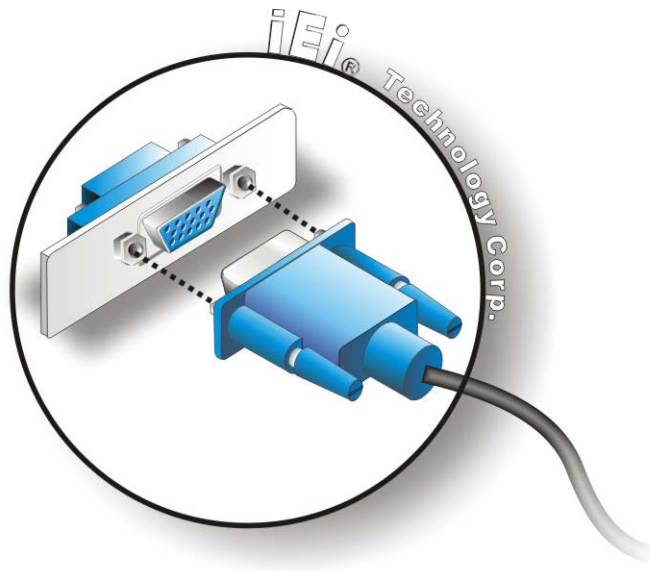

Figure 4-15: VGA Connector

Step 4: **Secure the connector.** Secure the DB-15 VGA connector from the VGA monitor to the external interface by tightening the two retention screws on either side of the connector.

4.6 Intel® AMT Setup Procedure

The KINO-AQ870 is featured with the Intel® Active Management Technology (AMT). To enable the Intel® AMT function, follow the steps below.

- Step 1:** Make sure the memory socket is installed with one DDR3 DIMM.
- Step 2:** Connect an Ethernet cable to one of the RJ-45 connector LANs which supports AMT.
- Step 3:** The AMI BIOS options regarding the Intel® ME or Intel® AMT must be enabled,
- Step 4:** Properly install the Intel® Management Engine Components drivers from the iAMT Driver & Utility directory in the driver CD.
- Step 5:** Configure the Intel® Management Engine BIOS extension (MEBx). To get into the Intel® MEBx settings, press <Ctrl+P> after a single beep during boot-up

KINO-AQ870

process. Enter the Intel® current ME password as it requires (the Intel® default password is **admin**).

**NOTE:**

To change the password, enter a new password following the strong password rule (containing at least one upper case letter, one lower case letter, one digit and one special character, and be at least eight characters).

Chapter

5

BIOS

KINO-AQ870

5.1 Introduction

The BIOS is programmed onto the BIOS chip. The BIOS setup program allows changes to certain system settings. This chapter outlines the options that can be changed.

5.1.1 Starting Setup

The UEFI BIOS is activated when the computer is turned on. The setup program can be activated in one of two ways.

1. Press the **DELETE** or **F2** key as soon as the system is turned on or
2. Press the **DELETE** or **F2** key when the “**Press Del to enter SETUP**” message appears on the screen.

If the message disappears before the **DELETE** or **F2** key is pressed, restart the computer and try again.

5.1.2 Using Setup

Use the arrow keys to highlight items, press **ENTER** to select, use the PageUp and PageDown keys to change entries, press **F1** for help and press **ESC** to quit. Navigation keys are shown in.

Key	Function
Up arrow	Move to the item above
Down arrow	Move to the item below
Left arrow	Move to the item on the left hand side
Right arrow	Move to the item on the right hand side
+	Increase the numeric value or make changes
-	Decrease the numeric value or make changes
Page up	Move to the next page
Page down	Move to the previous page

Key	Function
Esc	Main Menu – Quit and do not save changes into CMOS Status Page Setup Menu and Option Page Setup Menu -- Exit current page and return to Main Menu
F1	General help, only for Status Page Setup Menu and Option Page Setup Menu
F9	Load optimized defaults
F10	Save changes and Exit BIOS

Table 5-1: BIOS Navigation Keys

5.1.3 Getting Help

When **F1** is pressed a small help window describing the appropriate keys to use and the possible selections for the highlighted item appears. To exit the Help Window press **Esc** or the **F1** key again.

5.1.4 Unable to Reboot after Configuration Changes

If the computer cannot boot after changes to the system configuration is made, CMOS defaults. Use the jumper described in Chapter 4.

5.1.5 BIOS Menu Bar

The **menu bar** on top of the BIOS screen has the following main items:

- Main – Changes the basic system configuration.
- Advanced – Changes the advanced system settings.
- Chipset – Changes the chipset settings.
- Boot – Changes the system boot configuration.
- Security – Sets User and Supervisor Passwords.
- Save & Exit – Selects exit options and loads default settings

The following sections completely describe the configuration options found in the menu items at the top of the BIOS screen and listed above.

KINO-AQ870

5.2 Main

The **Main** BIOS menu (**BIOS Menu 1**) appears when the **BIOS Setup** program is entered.

The **Main** menu gives an overview of the basic system information.

Aptio Setup Utility - Copyright (C) 2012 American Megatrends, Inc.					
Main	Advanced	Chipset	Boot	Security	Save & Exit
BIOS Information					
BIOS Vendor	American Megatrends			Choose the system default language.	
Core Version	4.6.5.4				
Compliancy	UEFI 2.3.1; PI 1.2				
Project Version	SA92A 0.23 x64				
Build Date	05/03/2013 11:23:52				
iWDD Vendor	ICP				
iWDD Version	SA92ER10.bin				
Processor Information					
Name	Haswell				
Brand String	Genuine Intel(R)CPU 0000 @ 2.60GHz				
Frequency	2800 MHz				
Processor ID	306c2				
Stepping	B0				
Number of Processors	4Core(s) / 8Thread(s)				
Microcode Revision	ffff0006				
GT Info	GT2 (800 MHz)				
IGFX VBIOS Version	2170				
Memory RC Version	1.4.0.3				
Total Memory	4096 MB (DDR3)				
Memory Frequency	1333 MHz				
PCH Information					
Name	LynxPoint				
PCH SKU	Q87				
Stepping	04/C1				
LAN PHY Revision	A3				
ME FW Version	9.0.0.1310			←→: Select Screen	
ME Firmware SKU	5MB			↑ ↓: Select Item	
SPI Clock Frequency				EnterSelect	
DOFR Support	Supported			F1 General Help	
Read Status Clock Frequency	50 MHz			F2 Previous Values	
Write Status Clock Frequency	50 MHz			F3 Optimized Defaults	
Fast Read Status Clock Frequency	50 MHz			F4 Save	
System Language	[English]			ESC Exit	
System Date	[Fri 05/03/2012]				
System Time	[19:43:27]				
Access Level	Administrator				
Version 2.15.1236. Copyright (C) 2012 American Megatrends, Inc.					

BIOS Menu 1: Main

The Main menu lists the following system details:

- BIOS Information
- Processor Information
- Memory Information
- PCH Information
- SPI Clock Frequency

The Main menu has two user configurable fields:

➔ System Date [xx/xx/xx]

Use the **System Date** option to set the system date. Manually enter the day, month and year.

➔ System Time [xx:xx:xx]

Use the **System Time** option to set the system time. Manually enter the hours, minutes and seconds.

5.3 Advanced

Use the **Advanced** menu (**BIOS Menu 2**) to configure the CPU and peripheral devices through the following sub-menus:



WARNING!

Setting the wrong values in the sections below may cause the system to malfunction. Make sure that the settings made are compatible with the hardware.

KINO-AQ870

```

Aptio Setup Utility - Copyright (C) 2012 American Megatrends, Inc.
Main  Advanced  Chipset  Boot  Security  Save & Exit
-----
> ACPI Settings
> Trusted Computing
> CPU Configuration
> SATA Configuration
> Intel(R) Rapid Start Technology
> AMT Configuration
> USB Configuration
> F81866 Super IO Configuration
> F81866 H/M Monitor
> Serial Port Console Redirection
> iEi Feature

System ACPI Parameters

-----
<-->: Select Screen
↑↓: Select Item
Enter>Select
F1  General Help
F2  Previous Values
F3  Optimized Defaults
F4  Save
ESC Exit

Version 2.15.1236. Copyright (C) 2012 American Megatrends, Inc.

```

BIOS Menu 2: Advanced

5.3.1 ACPI Configuration

The **ACPI Configuration** menu (**BIOS Menu 3**) configures the Advanced Configuration and Power Interface (ACPI) options.

```

Aptio Setup Utility - Copyright (C) 2012 American Megatrends, Inc.
-----
Advanced
-----
ACPI Settings
ACPI Sleep State          [S1 only (CPU Stop
                          Clock)]

Select the highest ACPI
sleep state the system
will enter when the
SUSPEND button is
pressed.

-----
<-->: Select Screen
↑↓: Select Item
Enter>Select
F1  General Help
F2  Previous Values
F3  Optimized
Defaults
F4  Save
ESC Exit

Version 2.15.1236. Copyright (C) 2012 American Megatrends, Inc.

```

BIOS Menu 3: ACPI Configuration

→ ACPI Sleep State [S1 only (CPU Stop Clock)]

Use the **ACPI Sleep State** option to specify the sleep state the system enters when it is not being used.

- **Suspend Disabled** Disable the suspend function.
- **S1 only (CPU Stop Clock)** **DEFAULT** The system enters S1 (POS) sleep state. The system appears off. The CPU is stopped; RAM is refreshed; the system is running in a low power mode.
- **S3 only (Suspend to RAM)** The caches are flushed and the CPU is powered off. Power to the RAM is maintained. The computer returns slower to a working state, but more power is saved.
- **Both S1 and S3 available for OS to choose from** Both S1 and S3 are available, for OS to choose.

5.3.2 Trusted Computing

Use the **Trusted Computing** menu (**BIOS Menu 4**) to configure settings related to the Trusted Computing Group (TCG) Trusted Platform Module (TPM).

KINO-AQ870

```

Aptio Setup Utility - Copyright (C) 2012 American Megatrends, Inc.
  Advanced
Configuration
  Security Device Support          [Disable]
Current Status Information
  NO Security Device Found
-----
<=>: Select Screen
↑↓: Select Item
Enter>Select
F1   General Help
F2   Previous Values
F3   Optimized
Defaults
F4   Save
ESC  Exit
Version 2.15.1236. Copyright (C) 2012 American Megatrends, Inc.
  
```

BIOS Menu 4: Trusted Computing

➔ Security Device Support [Disable]

Use the **Security Device Support** option to configure support for the security device.

- ➔ **Disable** **DEFAULT** Security device support is disabled.
- ➔ **Enable** Security device support is enabled.

5.3.3 CPU Configuration

Use the **CPU Configuration** menu (**BIOS Menu 5**) to view detailed CPU specifications and configure the CPU.

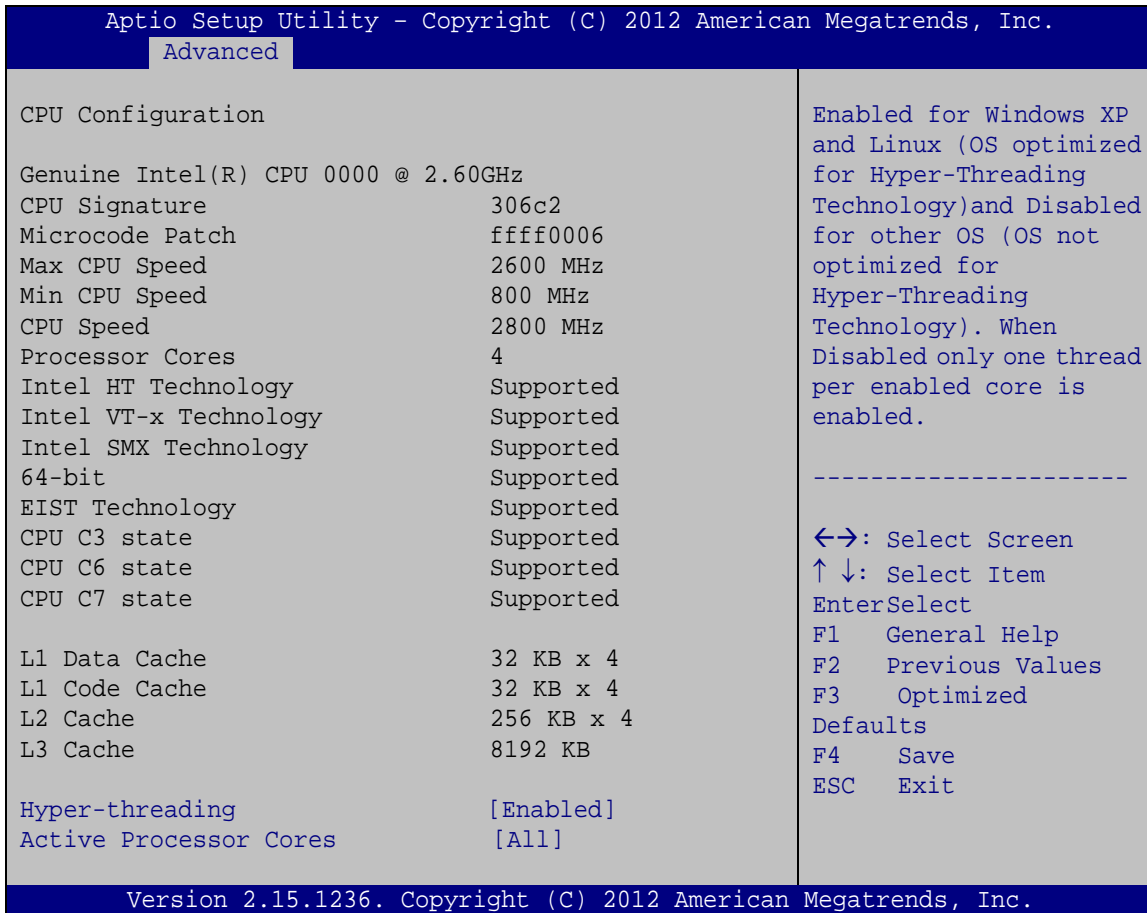

BIOS Menu 5: CPU Configuration

➔ Hyper-Threading [Enabled]

Use the Hyper-Threading option to enable or disable the CPU hyper threading function.

- ➔ **Disabled** Disables the use of hyper threading technology
- ➔ **Enabled** **DEFAULT** Enables the use of hyper threading technology

KINO-AQ870

→ Active Processor Cores [All]

Use the **Active Processor Cores** option to configure the number of the active processor cores.

- **All** **DEFAULT** Active all of the processor cores
- **1** Active one of the processor cores
- **2** Active two of the processor cores
- **3** Active three of the processor cores

5.3.4 SATA Configuration

Use the **SATA Configuration** menu (**BIOS Menu 6**) to change and/or set the configuration of the SATA devices installed in the system.

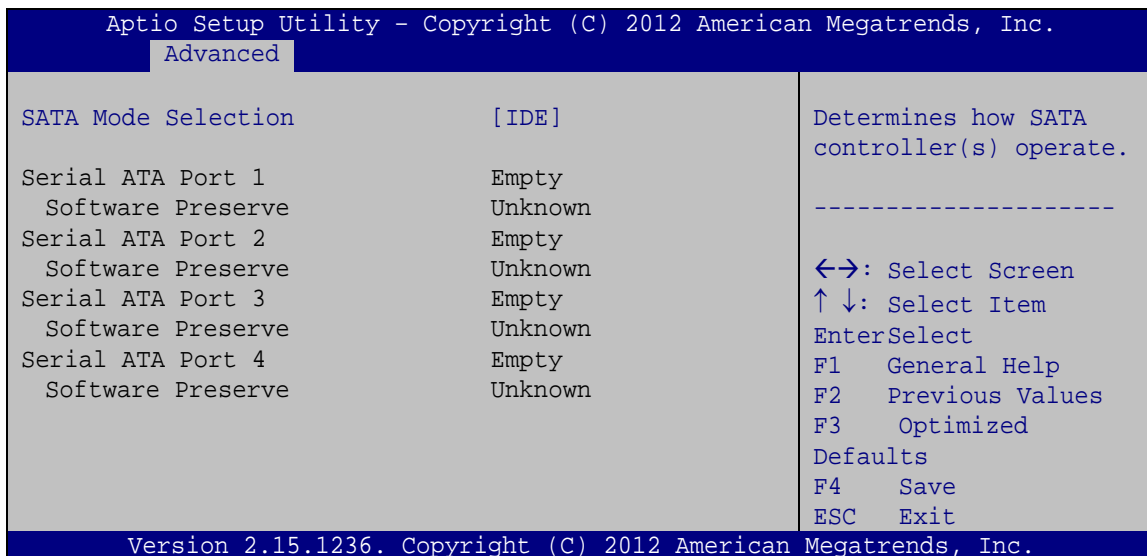

BIOS Menu 6: SATA Configuration

→ SATA Mode Selection [IDE]

Use the **SATA Mode Selection** option to configure SATA devices as normal IDE devices.

- **IDE** **DEFAULT** Configures SATA devices as normal IDE device.
- **AHCI** Configures SATA devices as AHCI device.

- ➔ **RAID** Configures SATA devices as RAID device.

5.3.5 Intel(R) Rapid Start Technology

Use the **Intel(R) Rapid Start Technology** menu (**BIOS Menu 7**) to configure Intel® Rapid Start Technology support.

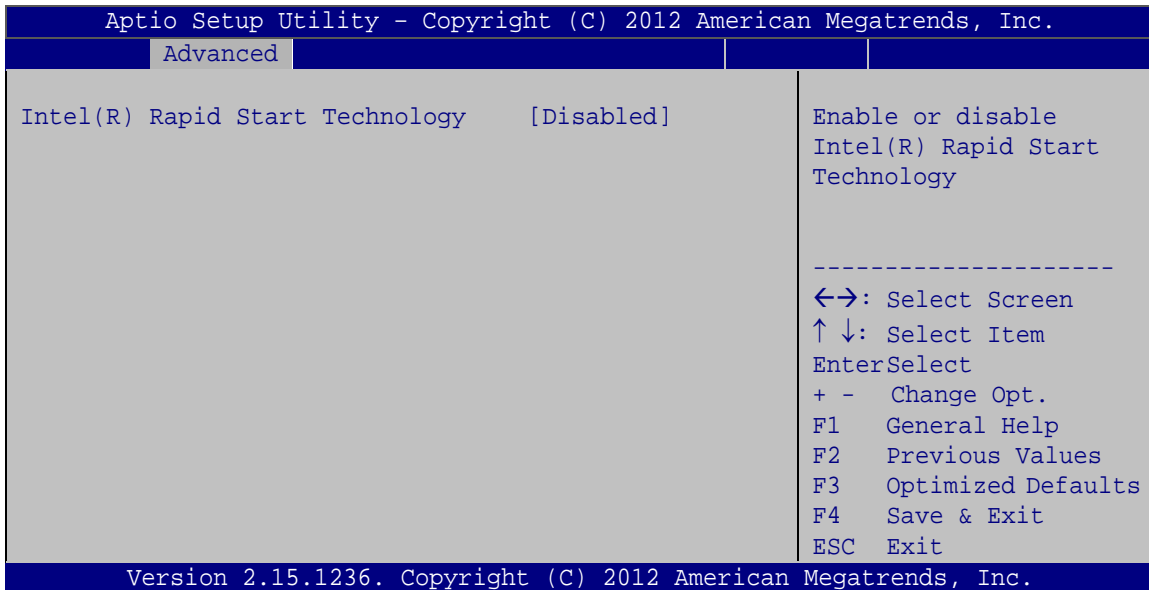

BIOS Menu 7: Intel(R) Rapid Start Technology

- ➔ Intel(R) Rapid Start Technology [Disabled]

Use **Intel(R) Rapid Start Technology** option to configure Intel® Rapid Start Technology function.

- ➔ **Disabled** **DEFAULT** Intel® Rapid Start Technology is disabled
- ➔ **Enabled** Intel® Rapid Start Technology is enabled

5.3.6 AMT Configuration

The **AMT Configuration** menu (**BIOS Menu 8**) allows the advanced power management options to be configured.

KINO-AQ870

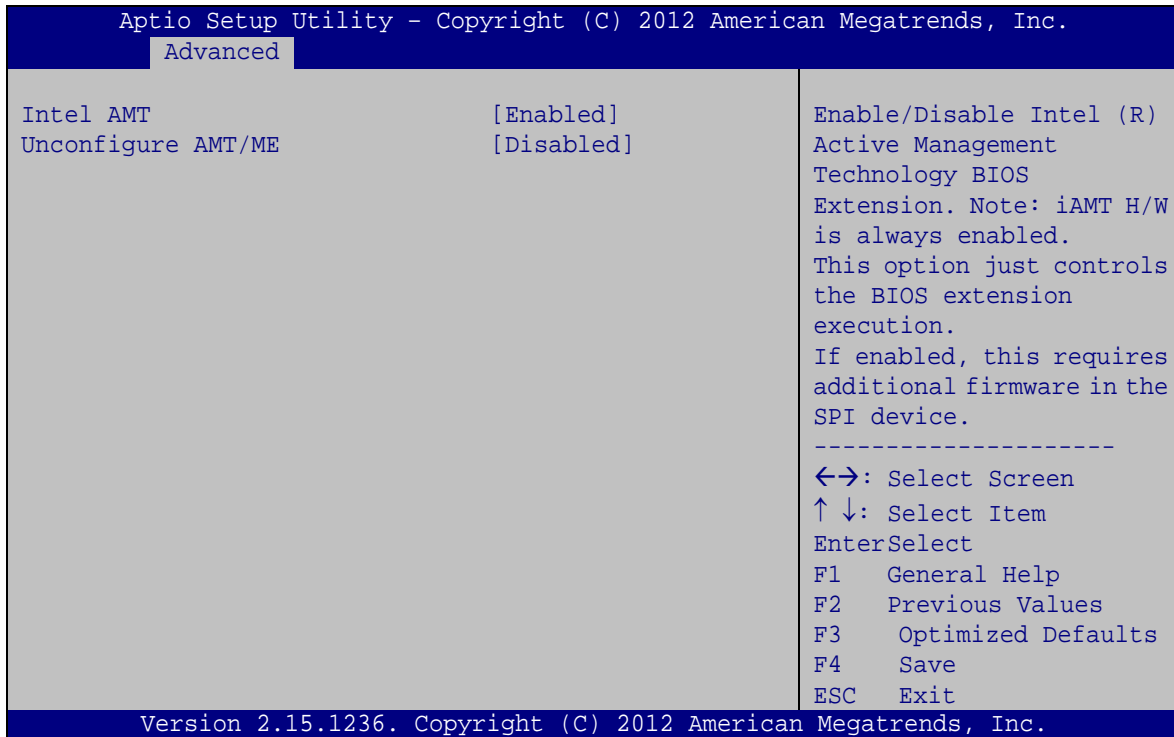

BIOS Menu 8: AMT Configuration

→ Intel AMT [Enabled]

Use **Intel AMT** option to enable or disable the Intel® AMT function.

- **Disabled** Intel® AMT is disabled
- **Enabled** **DEFAULT** Intel® AMT is enabled

→ Unconfigure AMT/ME [Dis abled]

Use the **Unconfigure AMT/ME** option to perform AMT/ME unconfigure without password operation.

- **Disabled** **DEFAULT** Not perform AMT/ME unconfigure
- **Enabled** To perform AMT/ME unconfigure

5.3.7 USB Configuration

Use the **USB Configuration** menu (**BIOS Menu 9**) to read USB configuration information and configure the USB settings.

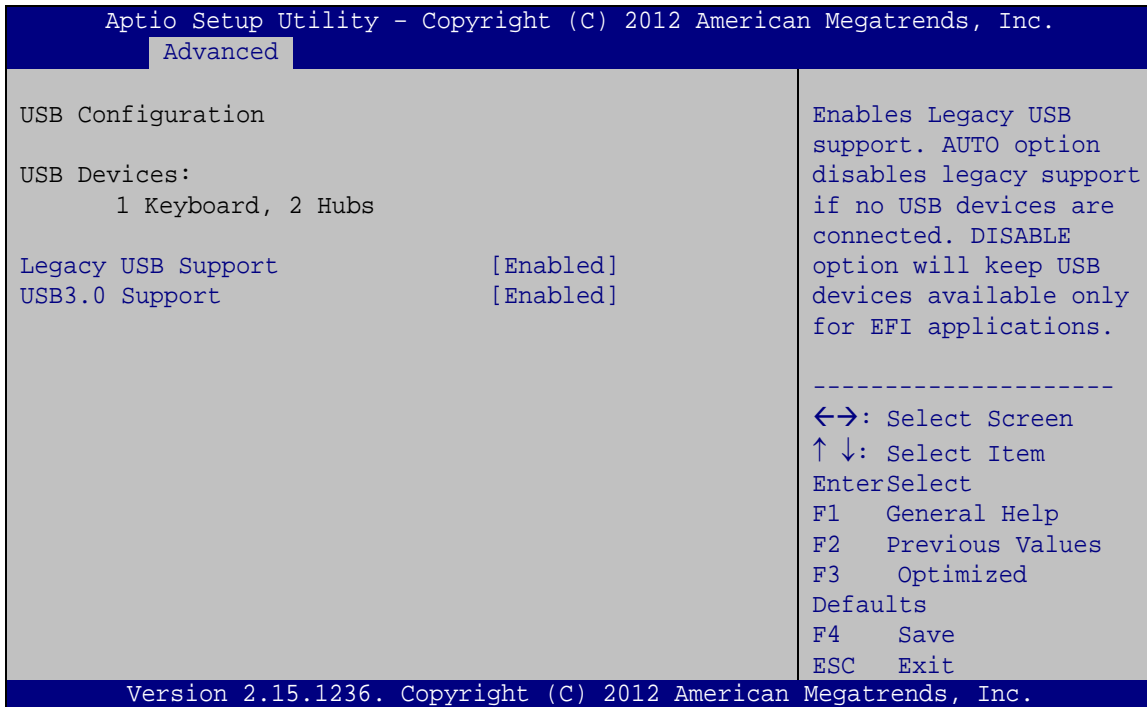

BIOS Menu 9: USB Configuration

➔ USB Devices

The **USB Devices Enabled** field lists the USB devices that are enabled on the system

➔ Legacy USB Support [Enabled]

Use the **Legacy USB Support** BIOS option to enable USB mouse and USB keyboard support. Normally if this option is not enabled, any attached USB mouse or USB keyboard does not become available until a USB compatible operating system is fully booted with all USB drivers loaded. When this option is enabled, any attached USB mouse or USB keyboard can control the system even when there is no USB driver loaded onto the system.

➔ **Enabled** **DEFAULT** Legacy USB support enabled

KINO-AQ870

- ➔ **Disabled** Legacy USB support disabled
- ➔ **Auto** Legacy USB support disabled if no USB devices are connected

➔ USB3.0 Support [Enabled]

Use the **USB3.0 Support** option to enable or disable USB3.0 support on the system.

- ➔ **Enabled** **DEFAULT** USB3.0 support enabled
- ➔ **Disabled** USB3.0 support disabled

5.3.8 F81866 Super IO Configuration

Use the **F81866 Super IO Configuration** menu (**BIOS Menu 10**) to set or change the configurations for the serial ports.

```

Aptio Setup Utility - Copyright (C) 2012 American Megatrends, Inc.
  Advanced
F81866 Super IO Configuration
F81866 Super IO Chip          F81866
> Serial Port 1 Configuration
> Serial Port 2 Configuration
> Serial Port 3 Configuration
> Serial Port 4 Configuration
> Serial Port 5 Configuration
> Serial Port 6 Configuration
Set Parameters of Serial
Port 1 (COMA)
-----
<->: Select Screen
↑ ↓: Select Item
Enter>Select
F1  General Help
F2  Previous Values
F3  Optimized
Defaults
F4  Save
ESC Exit
Version 2.15.1236. Copyright (C) 2012 American Megatrends, Inc.

```

BIOS Menu 10: Super IO Configuration

5.3.8.1 Serial Port n Configuration

Use the **Serial Port n Configuration** menu (**BIOS Menu 11**) to configure the serial port n.

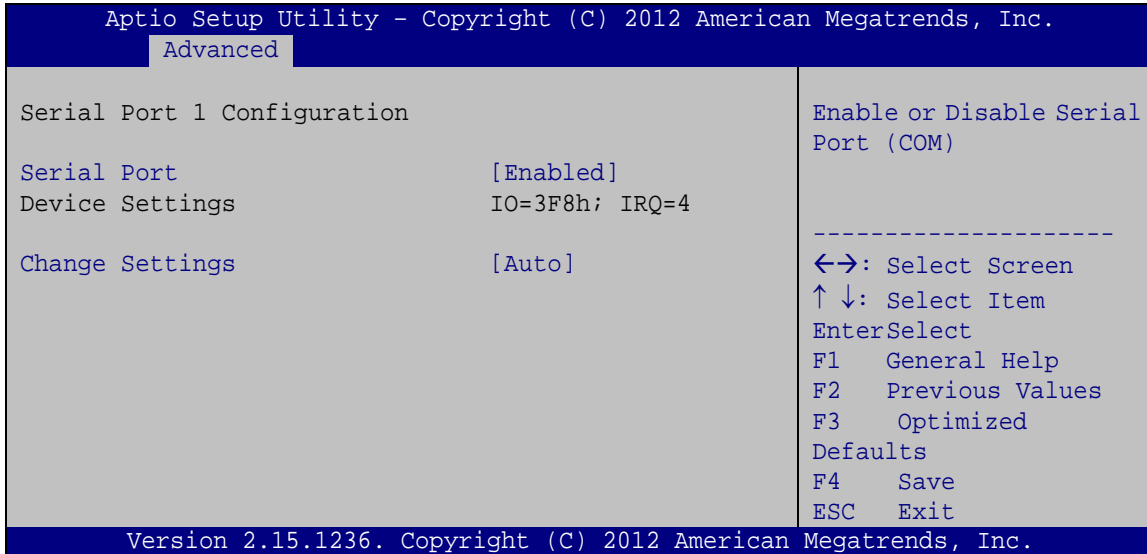

BIOS Menu 11: Serial Port n Configuration Menu

5.3.8.1.1 Serial Port 1 Configuration

➔ Serial Port [Enabled]

Use the **Serial Port** option to enable or disable the serial port.

- ➔ **Disabled** Disable the serial port
- ➔ **Enabled** **DEFAULT** Enable the serial port

➔ Change Settings [Auto]

Use the **Change Settings** option to change the serial port IO port address and interrupt address.

- ➔ **Auto** **DEFAULT** The serial port IO port address and interrupt address are automatically detected.
- ➔ **IO=3F8h;**
IRQ=4 Serial Port I/O port address is 3F8h and the interrupt address is IRQ4

KINO-AQ870

- ➔ **IO=3F8h;** Serial Port I/O port address is 3E8h and the interrupt
IRQ=3, 4 address is IRQ3, 4
- ➔ **IO=2F8h;** Serial Port I/O port address is 2F8h and the interrupt
IRQ=3, 4 address is IRQ3, 4

5.3.8.1.2 Serial Port 2 Configuration

➔ Serial Port [Enabled]

Use the **Serial Port** option to enable or disable the serial port.

- ➔ **Disabled** Disable the serial port
- ➔ **Enabled** **DEFAULT** Enable the serial port

➔ Change Settings [Auto]

Use the **Change Settings** option to change the serial port IO port address and interrupt address.

- ➔ **Auto** **DEFAULT** The serial port IO port address and interrupt address
are automatically detected.
- ➔ **IO=2F8h;** Serial Port I/O port address is 2F8h and the interrupt
IRQ=3 address is IRQ3
- ➔ **IO=3F8h;** Serial Port I/O port address is 3F8h and the interrupt
IRQ=3, 4 address is IRQ3, 4
- ➔ **IO=2F8h;** Serial Port I/O port address is 2F8h and the interrupt
IRQ=3, 4 address is IRQ3, 4

➔ Device Mode [RS232]

The **Device Mode** shows Serial Port 2 provides RS-232 communications.

5.3.8.1.3 Serial Port 3 Configuration

→ Serial Port [Enabled]

Use the **Serial Port** option to enable or disable the serial port.

- **Disabled** Disable the serial port
- **Enabled** **DEFAULT** Enable the serial port

→ Change Settings [Auto]

Use the **Change Settings** option to change the serial port IO port address and interrupt address.

- **Auto** **DEFAULT** The serial port IO port address and interrupt address are automatically detected.
- **IO=3E8h;**
IRQ=10 Serial Port I/O port address is 3E8h and the interrupt address is IRQ10
- **IO=3E8h;**
IRQ=10, 11 Serial Port I/O port address is 3E8h and the interrupt address is IRQ10, 11
- **IO=2E8h;**
IRQ=10, 11 Serial Port I/O port address is 2E8h and the interrupt address is IRQ10, 11

→ Device Mode [RS232]

The **Device Mode** shows Serial Port 3 provides RS-232 communications.

5.3.8.1.4 Serial Port 4 Configuration

→ Serial Port [Enabled]

Use the **Serial Port** option to enable or disable the serial port.

- **Disabled** Disable the serial port

KINO-AQ870

→ **Enabled** **DEFAULT** Enable the serial port

→ Change Settings [Auto]

Use the **Change Settings** option to change the serial port IO port address and interrupt address.

→ **Auto** **DEFAULT** The serial port IO port address and interrupt address are automatically detected.

→ **IO=2E8h;**
IRQ=10 Serial Port I/O port address is 2E8h and the interrupt address is IRQ10

→ **IO=3E8h;**
IRQ=10, 11 Serial Port I/O port address is 3E8h and the interrupt address is IRQ10, 11

→ **IO=2E8h;**
IRQ=10, 11 Serial Port I/O port address is 2E8h and the interrupt address is IRQ10, 11

→ Device Mode [RS232]

The **Device Mode** shows Serial Port 4 provides RS-232 communications.

5.3.8.1.5 Serial Port 5 Configuration

→ Serial Port [Enabled]

Use the **Serial Port** option to enable or disable the serial port.

→ **Disabled** Disable the serial port

→ **Enabled** **DEFAULT** Enable the serial port

→ Change Settings [Auto]

Use the **Change Settings** option to change the serial port IO port address and interrupt address.

- ➔ **Auto** **DEFAULT** The serial port IO port address and interrupt address are automatically detected.
- ➔ **IO=2D0h;**
IRQ=10 Serial Port I/O port address is 2D0h and the interrupt address is IRQ10
- ➔ **IO=2D0h;**
IRQ=10, 11 Serial Port I/O port address is 2D0h and the interrupt address is IRQ10, 11
- ➔ **IO=2D8h;**
IRQ=10, 11 Serial Port I/O port address is 2D8h and the interrupt address is IRQ10, 11

➔ **Device Mode [RS232]**

The **Device Mode** shows Serial Port 5 provides RS-232 communications.

5.3.8.1.6 Serial Port 6 Configuration

➔ **Serial Port [Enabled]**

Use the **Serial Port** option to enable or disable the serial port.

- ➔ **Disabled** Disable the serial port
- ➔ **Enabled** **DEFAULT** Enable the serial port

➔ **Change Settings [Auto]**

Use the **Change Settings** option to change the serial port IO port address and interrupt address.

- ➔ **Auto** **DEFAULT** The serial port IO port address and interrupt address are automatically detected.
- ➔ **IO=2D8h;**
IRQ=10 Serial Port I/O port address is 2D8h and the interrupt address is IRQ10
- ➔ **IO=2D0h;**
IRQ=10, 11 Serial Port I/O port address is 2D0h and the interrupt address is IRQ10, 11

KINO-AQ870

➔ **IO=2D8h;** Serial Port I/O port address is 2D8h and the interrupt
IRQ=10, 11 address is IRQ10, 11

➔ Device Mode [RS485/RS422]

The **Device Mode** shows Serial Port 6 provides RS-485/RS-422 communications.

5.3.9 F81866 H/W Monitor

The **F8186 H/W Monitor** menu (**BIOS Menu 12**) shows the operating temperature, fan speeds and system voltages.

```

Aptio Setup Utility - Copyright (C) 2012 American Megatrends, Inc.
Advanced
PC Health Status
> Smart Fan Mode Configuration
CPU temperature           :+42 C
SYS temperature          :+31 C
VCC3V                    :+3.408 V
V_core                   :+1.024 V
+1.05V                   :+1.320 V
VDDR                     :+1.520 V
VSB5V                    :+5.040 V
VSB3V                    :+3.376 V
VBAT                     :+3.184 V
-----
<->: Select Screen
↑ ↓: Select Item
Enter>Select
F1   General Help
F2   Previous Values
F3   Optimized
Defaults
F4   Save
ESC  Exit
Version 2.15.1236. Copyright (C) 2012 American Megatrends, Inc.
  
```

BIOS Menu 12: Hardware Health Configuration

➔ PC Health Status

The following system parameters and values are shown. The system parameters that are monitored are:

- System Temperatures:
 - CPU Temperature

- SYS Temperature
- Voltages:
 - VCC3V
 - V_core
 - +1.05V
 - VDDR
 - VSB5V
 - VSB3V
 - VBAT

5.3.9.1 Smart Fan Mode Configuration

Use the **Smart Fan Mode Configuration** submenu (**BIOS Menu 13**) to configure the smart fan temperature and speed settings.

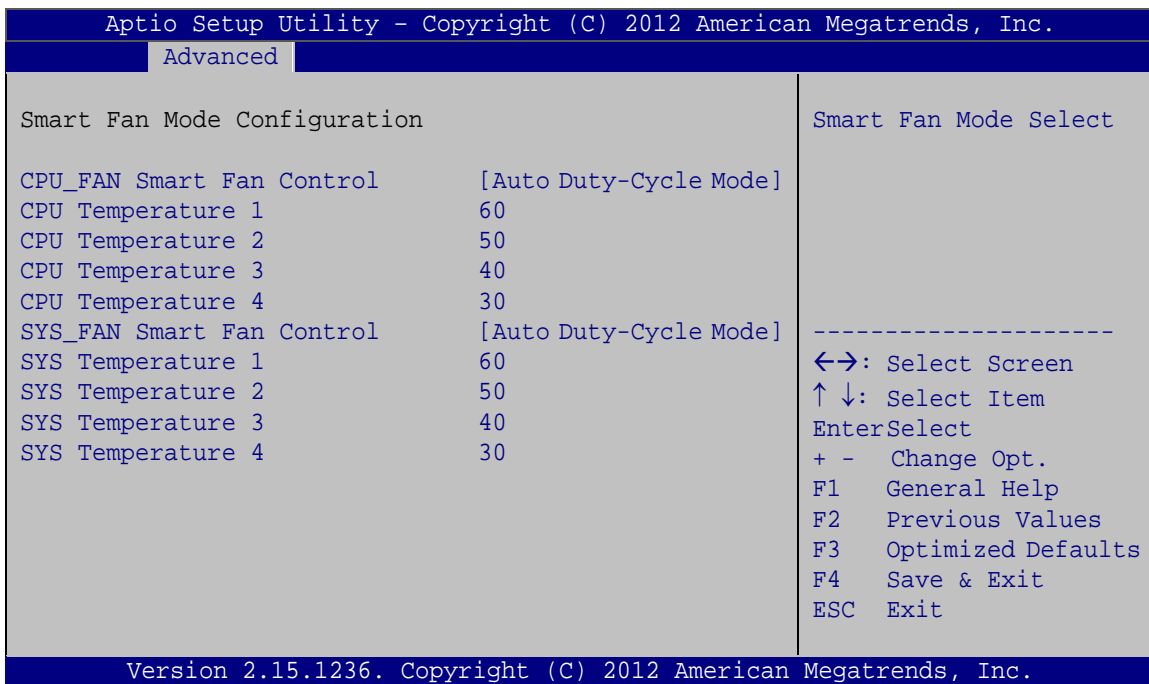

BIOS Menu 13: FAN 1 Configuration

➔ CPU_FAN Smart Fan Control [Auto Duty-Cycle Mode]

Use the **CPU_FAN Smart Fan Control** option to configure the CPU Smart Fan.

KINO-AQ870

- **Manual Duty Mode** The fan spins at the speed set in Manual by Duty Cycle settings
- **Auto Duty-Cycle Mode** DEFAULT The fan adjusts its speed using Auto by Duty-Cycle settings

→ CPU Temperature n

Use the + or – key to change the fan **CPU Temperature n** value. Enter a decimal number between 1 and 100.

→ SYS_FAN Smart Fan Control [Auto Duty-Cycle Mode]

Use the **SYS_FAN Smart Fan Control** option to configure the System Smart Fan.

- **Manual Duty Mode** The fan spins at the speed set in Manual by Duty Cycle settings
- **Auto Duty-Cycle Mode** DEFAULT The fan adjusts its speed using Auto by Duty-Cycle settings

→ SYS Temperature n

Use the + or – key to change the fan **SYS Temperature n** value. Enter a decimal number between 1 and 100.

5.3.10 Serial Port Console Redirection

The **Serial Port Console Redirection** menu (**BIOS Menu 14**) allows the console redirection options to be configured. Console redirection allows users to maintain a system remotely by re-directing keyboard input and text output through the serial port.

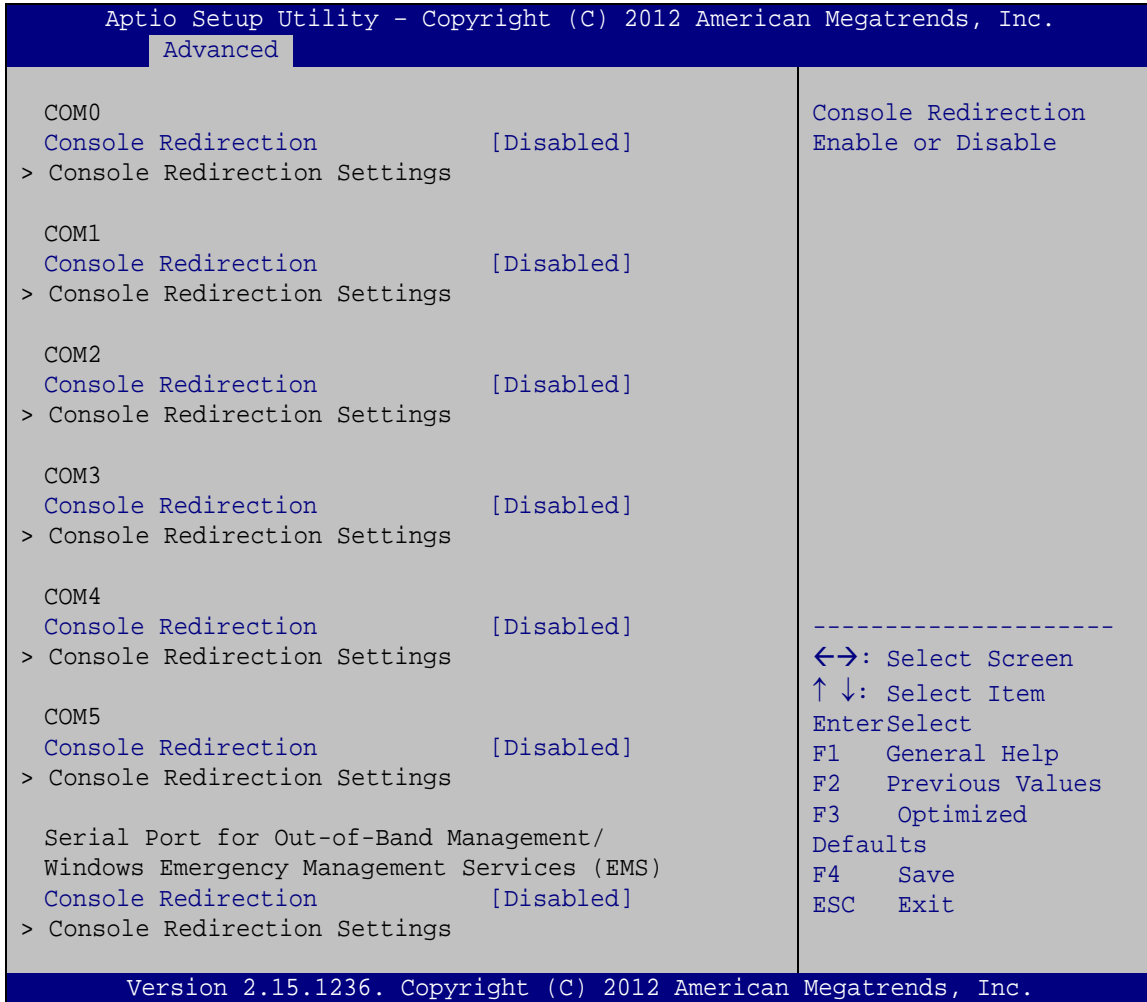

BIOS Menu 14: Serial Port Console Redirection

→ Console Redirection [Disabled]

Use **Console Redirection** option to enable or disable the console redirection function.

- **Disabled** **DEFAULT** Disabled the console redirection function
- **Enabled** Enabled the console redirection function

5.3.10.1 Console Redirection Settings

The **Console Redirection Settings** menu (**BIOS Menu 15**) allows the console redirection options to be configured. The option is active when Console Redirection option is enabled.

KINO-AQ870

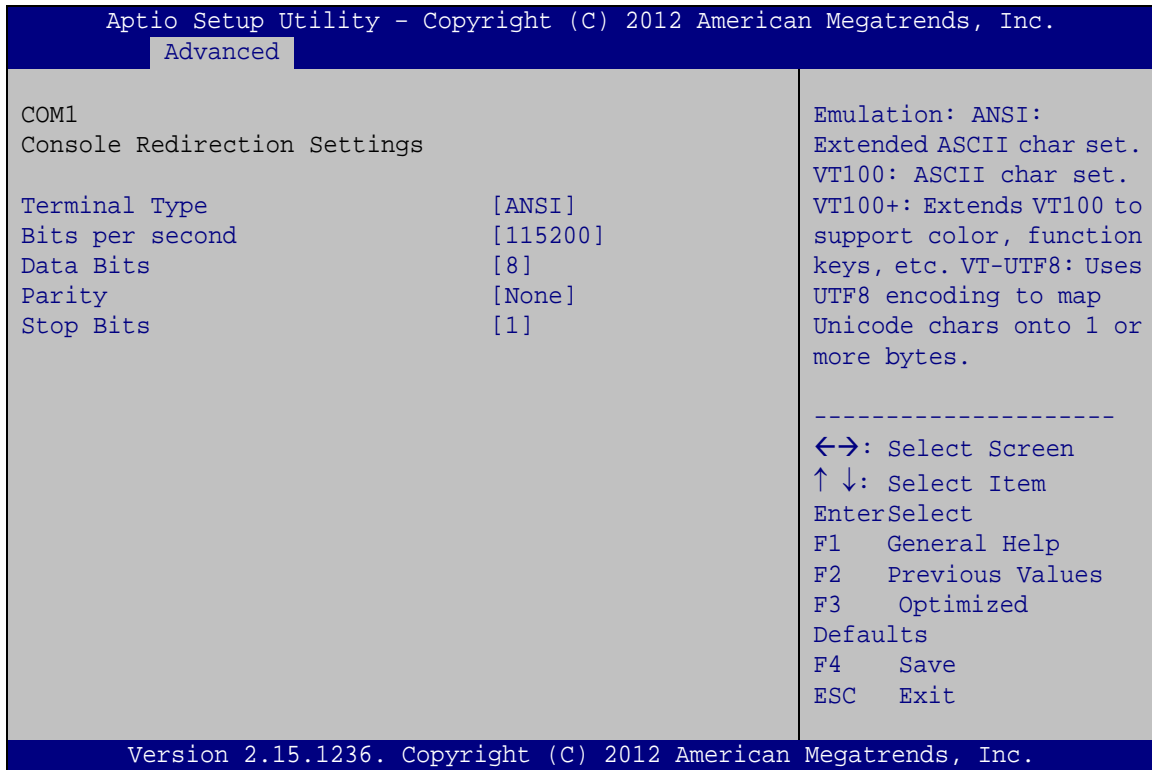

BIOS Menu 15: Console Redirection Settings

→ Terminal Type [ANSI]

Use the **Terminal Type** option to specify the remote terminal type.

- **VT100** The target terminal type is VT100
- **VT100+** The target terminal type is VT100+
- **VT-UTF8** The target terminal type is VT-UTF8
- **ANSI** **DEFAULT** The target terminal type is ANSI

→ Bits per second [115200]

Use the **Bits per second** option to specify the serial port transmission speed. The speed must match the other side. Long or noisy lines may require lower speeds.

- **9600** Sets the serial port transmission speed at 9600.
- **19200** Sets the serial port transmission speed at 19200.

- **38400** Sets the serial port transmission speed at 38400.
- **57600** Sets the serial port transmission speed at 57600.
- **115200** **DEFAULT** Sets the serial port transmission speed at 115200.

→ Data Bits [8]

Use the **Data Bits** option to specify the number of data bits.

- **7** Sets the data bits at 7.
- **8** **DEFAULT** Sets the data bits at 8.

→ Parity [None]

Use the **Parity** option to specify the parity bit that can be sent with the data bits for detecting the transmission errors.

- **None** **DEFAULT** No parity bit is sent with the data bits.
- **Even** The parity bit is 0 if the number of ones in the data bits is even.
- **Odd** The parity bit is 0 if the number of ones in the data bits is odd.
- **Mark** The parity bit is always 1. This option does not provide error detection.
- **Space** The parity bit is always 0. This option does not provide error detection.

→ Stop Bits [1]

Use the **Stop Bits** option to specify the number of stop bits used to indicate the end of a serial data packet. Communication with slow devices may require more than 1 stop bit.

- **1** **DEFAULT** Sets the number of stop bits at 1.
- **2** Sets the number of stop bits at 2.

KINO-AQ870

5.3.11 IEI Feature

Use the **IEI Feature** menu (**BIOS Menu 16**) to configure One Key Recovery function.

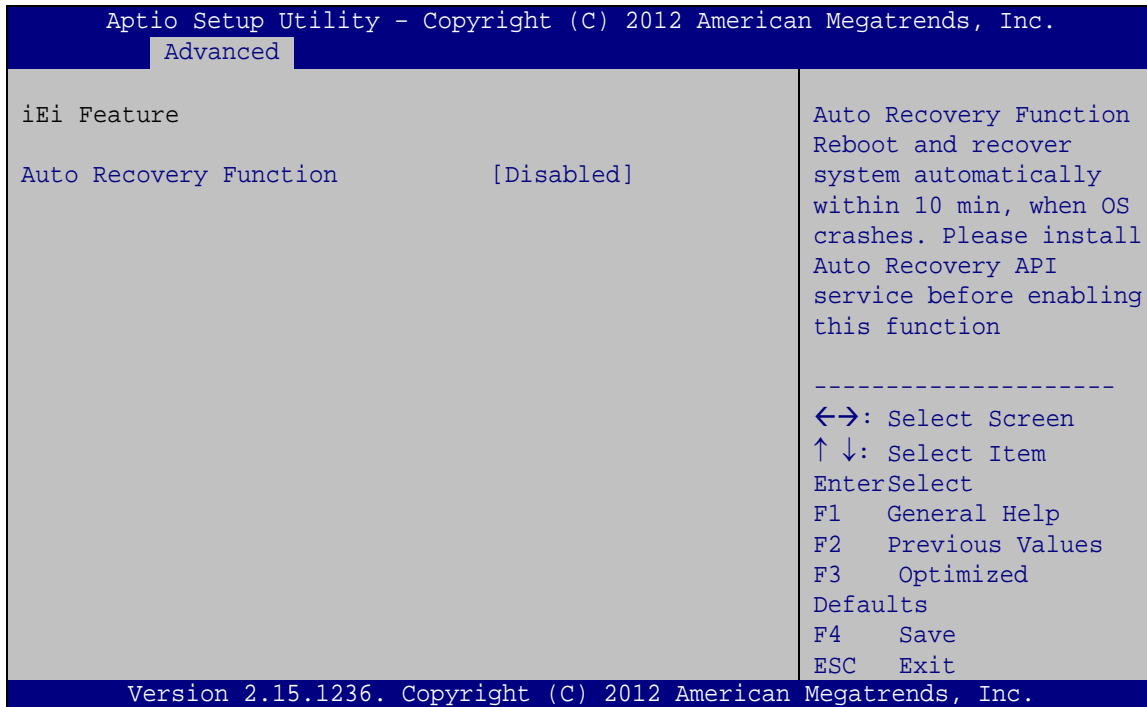

BIOS Menu 16: IEI Feature

➔ Auto Recovery Function [Disabled]

Use the **Auto Recovery Function** BIOS option to enable or disable the auto recovery function of the IEI One Key Recovery.

- ➔ **Disabled** **DEFAULT** Auto recovery function disabled
- ➔ **Enabled** Auto recovery function enabled

5.4 Chipset

Use the **Chipset** menu (**BIOS Menu 17**) to access the PCH-IO and System Agent (SA) configuration menus.



WARNING!

Setting the wrong values for the Chipset BIOS selections in the Chipset BIOS menu may cause the system to malfunction.

```
Aptio Setup Utility - Copyright (C) 2012 American Megatrends, Inc.
Main   Advanced  Chipset  Boot   Security  Save & Exit
-----
> PCH-IO Configuration
> System Agent (SA) Configuration

-----
<->: Select Screen
↑ ↓: Select Item
Enter>Select
F1   General Help
F2   Previous Values
F3   Optimized
Defaults
F4   Save
ESC  Exit

Version 2.15.1236. Copyright (C) 2012 American Megatrends, Inc.
```

BIOS Menu 17: Chipset

KINO-AQ870

5.4.1 PCH-IO Configuration

Use the **PCH-IO Configuration** menu (**BIOS Menu 18**) to configure the PCH chipset.

```

Aptio Setup Utility - Copyright (C) 2012 American Megatrends, Inc.
Chipset
Intel PCH RC Version          1.4.0.0
Intel PCH SKU Name           Q87
Auto Power Button Status     [Enabled(AT)]
Power Saving Function(ERP)   [Disabled]
> PCH Azalia Configuration

-----
<->: Select Screen
↑↓: Select Item
Enter>Select
F1   General Help
F2   Previous Values
F3   Optimized
Defaults
F4   Save
ESC  Exit

Version 2.15.1236. Copyright (C) 2012 American Megatrends, Inc.
  
```

BIOS Menu 18:PCH-IO Configuration

➔ Power Saving Function(ERP) [Disabled]

Use the **Power Saving Function** BIOS option to enable or disable the power saving function.

- ➔ **Disabled** **DEFAULT** Power saving function is disabled.
- ➔ **Enabled** Power saving function is enabled. It will reduce power consumption when the system is off.

5.4.1.1 PCH Azalia Configuration

Use the **PCH Azalia Configuration** submenu (**BIOS Menu 19**) to configure the PCH Azalia device.

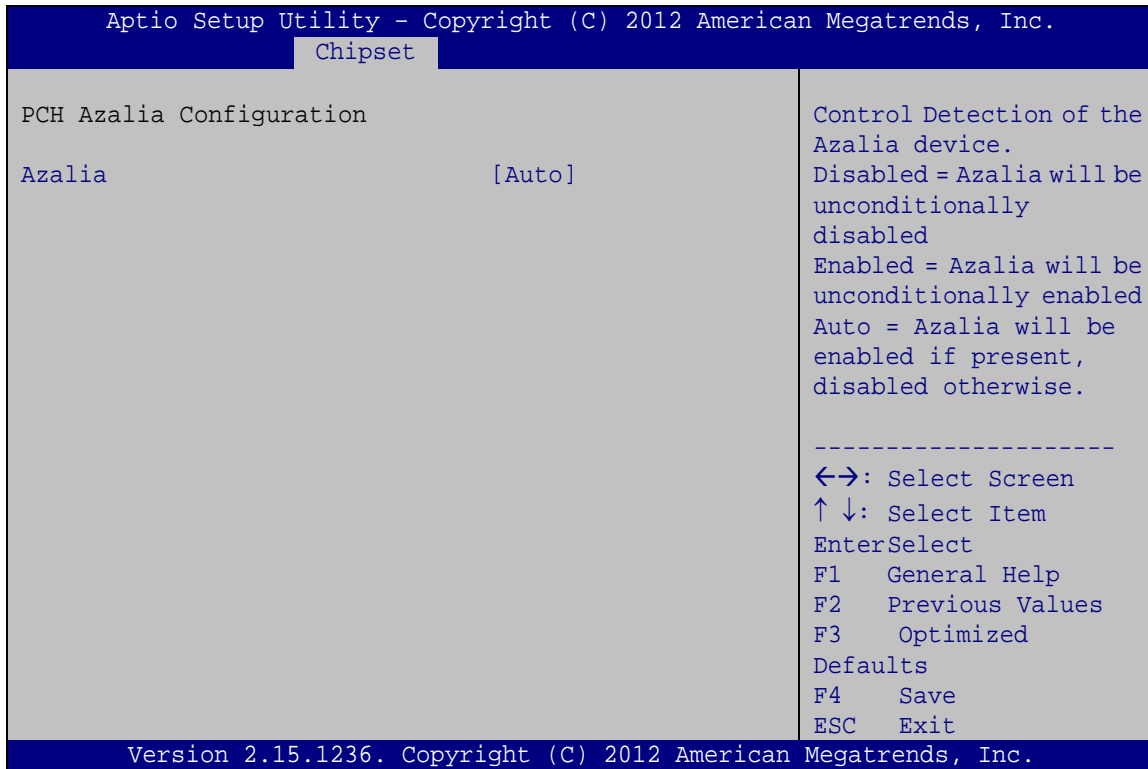

BIOS Menu 19:PCH-IO Configuration

➔ Azalia [Auto]

Use the **Azalia** option to enable or disable the High Definition Audio controller.

- ➔ **Disabled** The onboard High Definition Audio controller is disabled
- ➔ **Enabled** The onboard High Definition Audio controller automatically detected and enabled
- ➔ **Auto** **DEFAULT** The onboard High Definition Audio controller will be enabled if present, disabled otherwise.

KINO-AQ870

5.4.2 System Agent (SA) Configuration

Use the **System Agent (SA) Configuration** menu (**BIOS Menu 20**) to configure the graphics setting and memory setting.

```

Aptio Setup Utility - Copyright (C) 2012 American Megatrends, Inc.
Chipset
System Agent Bridge Name      Haswell
System Agent RC Version      1.4.0.0
VT-d Capability               Supported

VT-d                          [Disabled]

> Graphics Configuration

-----
<-->: Select Screen
↑ ↓: Select Item
Enter>Select
F1   General Help
F2   Previous Values
F3   Optimized
Defaults
F4   Save
ESC  Exit

Version 2.15.1236. Copyright (C) 2012 American Megatrends, Inc.
    
```

BIOS Menu 20: System Agent (SA) Configuration

➔ VT-d [Disabled]

Use the **VT-d** option to enable or disable VT-d support.

- ➔ **Disabled** **DEFAULT** Disables VT-d support.
- ➔ **Enabled** Enables VT-d support.

5.4.2.1 Graphics Configuration

Use the **Graphics Configuration** menu (**BIOS Menu 21**) to configure the video device connected to the system.

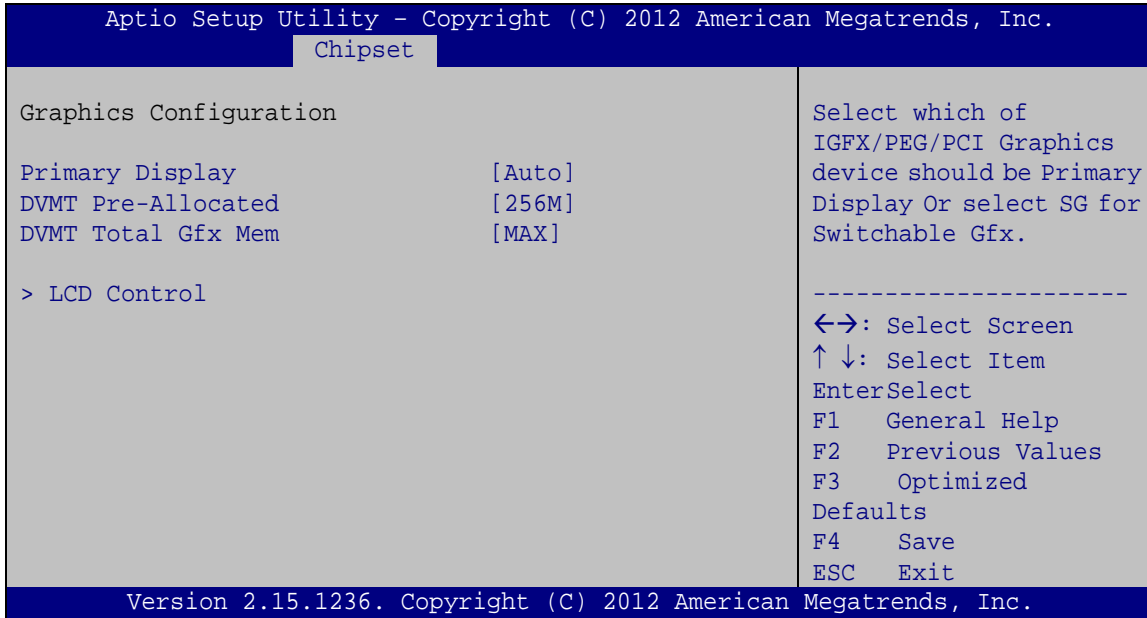

BIOS Menu 21: Graphics Configuration

➔ Primary Display [Auto]

Use the **Primary Display** option to select the primary graphics controller the system uses. The following options are available:

- Auto **Default**
- IGFX
- PEG
- PCI

➔ DVMT Pre-Allocated [256MB]

Use the **DVMT Pre-Allocated** option to set the amount of system memory allocated to the integrated graphics processor when the system boots. The system memory allocated can then only be used as graphics memory, and is no longer available to applications or the operating system. Configuration options are listed below:

- 32M
- 64M
- 128M
- 256M **Default**
- 512M

KINO-AQ870

→ DVMT Total Gfx Mem [MAX]

Use the **DVMT Total Gfx Mem** option to select DVMT5.0 total graphic memory size used by the internal graphic device. The following options are available:

- 128M
- 256M
- MAX **Default**

5.4.2.1.1 LCD Control

Use the **LCD Control** menu (**BIOS Menu 22**) to configure the video device connected to the system.

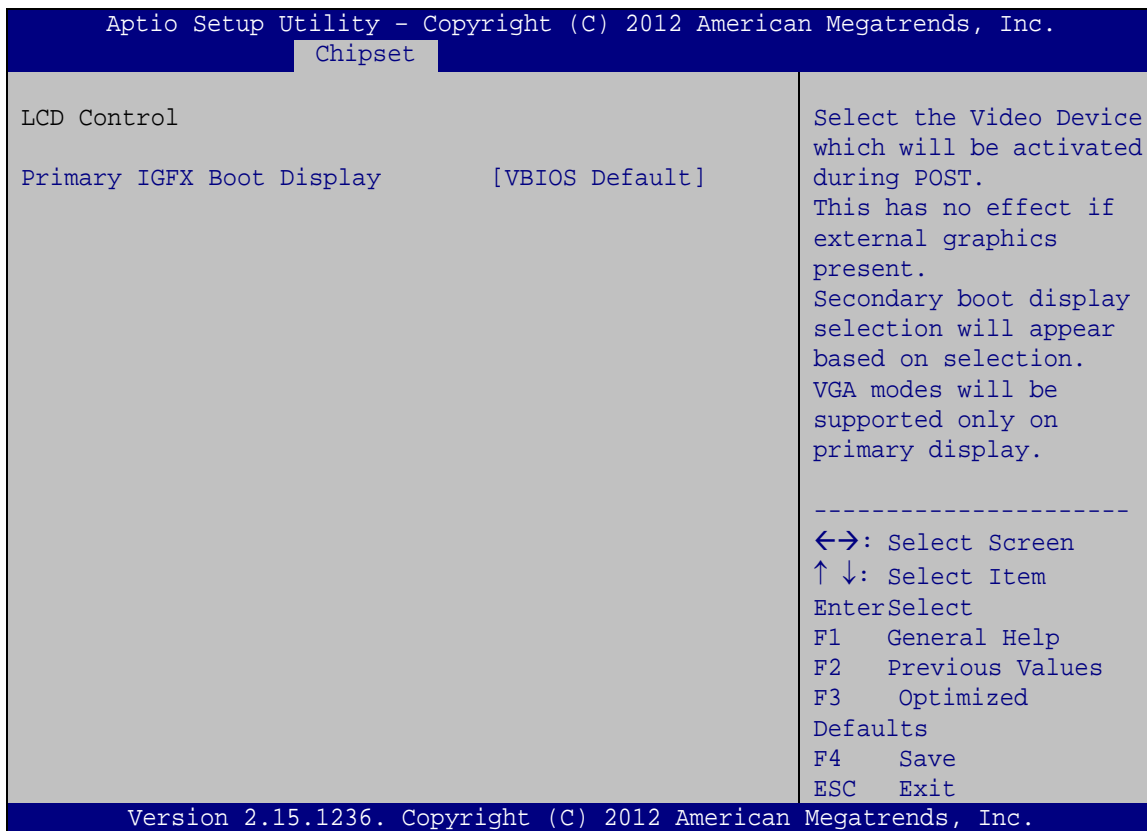

BIOS Menu 22: Graphics Configuration

→ Primary IGFX Boot Display [VBIOS Default]

Use the **Primary IGFX Boot Display** option to select the primary graphics controller the system uses. The following options are available:

- VBIOS Default **Default**
- DVI
- VGA

5.5 Boot

Use the **Boot** menu (**BIOS Menu 21**) to configure system boot options.

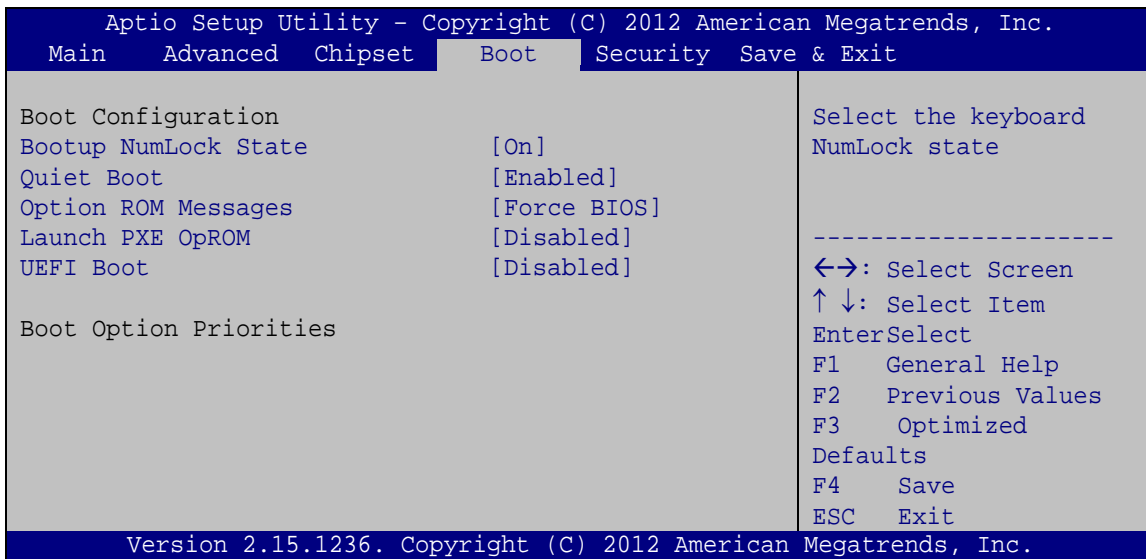

BIOS Menu 23: Boot

➔ Bootup NumLock State [On]

Use the **Bootup NumLock State** BIOS option to specify if the number lock setting must be modified during boot up.

➔ **On** **DEFAULT** Allows the Number Lock on the keyboard to be enabled automatically when the computer system boots up. This allows the immediate use of the 10-key numeric keypad located on the right side of the keyboard. To confirm this, the Number Lock LED light on the keyboard is lit.

KINO-AQ870

- **Off** Does not enable the keyboard Number Lock automatically. To use the 10-keys on the keyboard, press the Number Lock key located on the upper left-hand corner of the 10-key pad. The Number Lock LED on the keyboard lights up when the Number Lock is engaged.

- **Quiet Boot [Enabled]**

Use the **Quiet Boot** BIOS option to select the screen display when the system boots.

- **Disabled** Normal POST messages displayed
- **Enabled** **DEFAULT** OEM Logo displayed instead of POST messages

- **Option ROM Messages [Force BIOS]**

Use the **Option ROM Messages** option to set the Option ROM display mode.

- **Force BIOS** **DEFAULT** Sets display mode to force BIOS.
- **Keep Current** Sets display mode to current.

- **Launch PXE OpROM [Disabled]**

Use the **Launch PXE OpROM** option to enable or disable boot option for legacy network devices.

- **Disabled** **DEFAULT** Ignore all PXE Option ROMs
- **Enabled** Load PXE Option ROMs.

- **UEFI Boot [Disabled]**

Use the **UEFI Boot** option to enable or disable to boot from the UEFI devices.

- ➔ **Auto** If the first boot HDD is GPT then enable UEFI boot options, otherwise disable,
- ➔ **Enabled** Boot from UEFI devices is enabled.
- ➔ **Disabled** **DEFAULT** Boot from UEFI devices is disabled.

5.6 Security

Use the **Security** menu (**BIOS Menu 22**) to set system and user passwords.

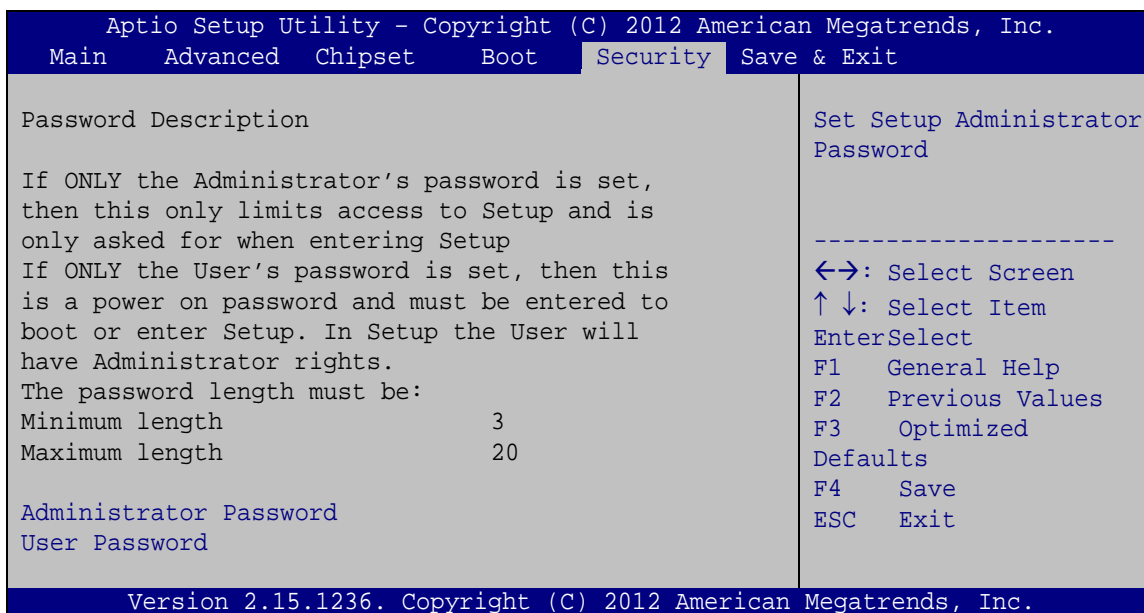

BIOS Menu 24: Security

- ➔ Administrator Password

Use the **Administrator Password** to set or change a administrator password.

- ➔ User Password

Use the **User Password** to set or change a user password.

5.7 Exit

Use the **Exit** menu (**BIOS Menu 25**) to load default BIOS values, optimal failsafe values and to save configuration changes.

KINO-AQ870

```

Aptio Setup Utility - Copyright (C) 2012 American Megatrends, Inc.
Main   Advanced  Chipset  Boot   Security  Save & Exit
-----
Save Changes and Reset
Discard Changes and Reset

Restore Defaults
Save as User Defaults
Restore User Defaults

Reset the system after
saving the changes.

-----
<->: Select Screen
↑ ↓: Select Item
Enter>Select
F1   General Help
F2   Previous Values
F3   Optimized
Defaults
F4   Save
ESC  Exit

Version 2.15.1236. Copyright (C) 2012 American Megatrends, Inc.

```

BIOS Menu 25:Exit

→ Save Changes and Reset

Use the **Save Changes and Reset** option to save the changes made to the BIOS options and to exit the BIOS configuration setup program.

→ Discard Changes and Reset

Use the **Discard Changes and Reset** option to exit the system without saving the changes made to the BIOS configuration setup program.

→ Restore Defaults

Use the **Restore Defaults** option to load the optimal default values for each of the parameters on the Setup menus. **F3 key can be used for this operation.**

→ Save as User Defaults

Use the **Save as User Defaults** option to save the changes done so far as user defaults.

→ Restore User Defaults

Use the **Restore User Defaults** option to restore the user defaults to all the setup options.

Appendix

A

BIOS Menu Options

KINO-AQ870

→ System Date [xx/xx/xx]	66
→ System Time [xx:xx:xx]	66
→ ACPI Sleep State [S1 only (CPU Stop Clock)]	68
→ Security Device Support [Disable]	69
→ Hyper-Threading [Enabled]	70
→ Active Processor Cores [All]	71
→ SATA Mode Selection [IDE]	71
→ Intel(R) Rapid Start Technology [Disabled]	72
→ Intel AMT [Enabled]	73
→ Unconfigure AMT/ME [Disabled]	73
→ USB Devices	74
→ Legacy USB Support [Enabled]	74
→ USB3.0 Support [Enabled]	75
→ Serial Port [Enabled]	76
→ Change Settings [Auto]	76
→ Serial Port [Enabled]	77
→ Change Settings [Auto]	77
→ Device Mode [RS232]	77
→ Serial Port [Enabled]	78
→ Change Settings [Auto]	78
→ Device Mode [RS232]	78
→ Serial Port [Enabled]	78
→ Change Settings [Auto]	79
→ Device Mode [RS232]	79
→ Serial Port [Enabled]	79
→ Change Settings [Auto]	79
→ Device Mode [RS232]	80
→ Serial Port [Enabled]	80
→ Change Settings [Auto]	80
→ Device Mode [RS485/RS422]	81
→ PC Health Status	81
→ CPU_FAN Smart Fan Control [Auto Duty-Cycle Mode]	82
→ CPU Temperature n	83
→ SYS_FAN Smart Fan Control [Auto Duty-Cycle Mode]	83

→	SYS Temperature n.....	83
→	Console Redirection [Disabled].....	84
→	Terminal Type [ANSI].....	85
→	Bits per second [115200].....	85
→	Data Bits [8]	86
→	Parity [None].....	86
→	Stop Bits [1].....	86
→	Auto Recovery Function [Disabled].....	87
→	Power Saving Function(ERP) [Disabled].....	89
→	Azalia [Auto]	90
→	VT-d [Disabled].....	91
→	Primary Display [Auto]	92
→	DVMT Pre-Allocated [256MB].....	92
→	DVMT Total Gfx Mem [MAX].....	93
→	Primary IGFX Boot Display [VBIOS Default]	93
→	Bootup NumLock State [On].....	94
→	Quiet Boot [Enabled]	95
→	Option ROM Messages [Force BIOS].....	95
→	Launch PXE OpROM [Disabled]	95
→	UEFI Boot [Disabled]	95
→	Administrator Password	96
→	User Password	96
→	Save Changes and Reset	97
→	Discard Changes and Reset	97
→	Restore Defaults	97
→	Save as User Defaults	97
→	Restore User Defaults	97

Appendix

B

One Key Recovery

B.1 One Key Recovery Introduction

The IEI one key recovery is an easy-to-use front end for the Norton Ghost system backup and recovery tool. This tool provides quick and easy shortcuts for creating a backup and reverting to that backup or reverting to the factory default settings.



NOTE:

The latest One Key Recovery software provides an auto recovery function that allows a system running Microsoft Windows OS to automatically restore from the factory default image after encountering a Blue Screen of Death (BSoD) or a hang for around 10 minutes. Please refer to Section B.3 for the detailed setup procedure.

The IEI One Key Recovery tool menu is shown below.

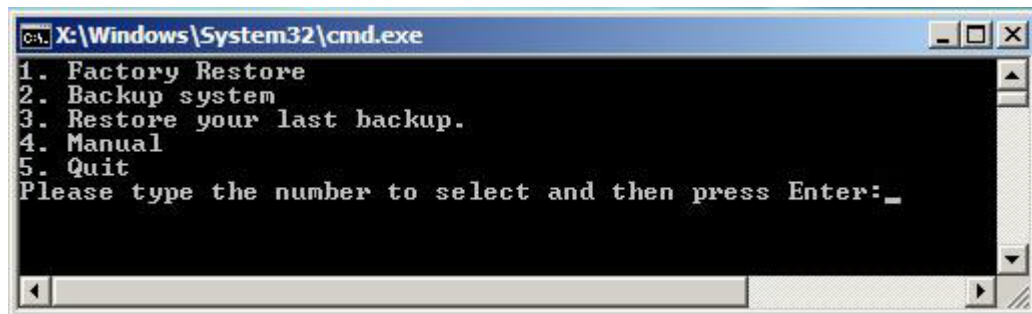

Figure B-1: IEI One Key Recovery Tool Menu

Prior to using the IEI One Key Recovery tool (as shown in **Figure B-1**) to backup or restore Windows system, five setup procedures are required.

1. Hardware and BIOS setup (see **Section B.2.1**)
2. Create partitions (see **Section B.2.2**)
3. Install operating system, drivers and system applications (see **Section B.2.3**)
4. Build the recovery partition (see **Section B.2.4**)
5. Create factory default image (see **Section B.2.5**)

KINO-AQ870

After completing the five initial setup procedures as described above, users can access the recovery tool by pressing <F3> while booting up the system. The detailed information of each function is described in **Section B.5**.



NOTE:

The initial setup procedures for Linux system are described in **Section B.3**.

B.1.1 System Requirement



NOTE:

The recovery CD can only be used with IEI products. The software will fail to run and a warning message will appear when used on non-IEI hardware.

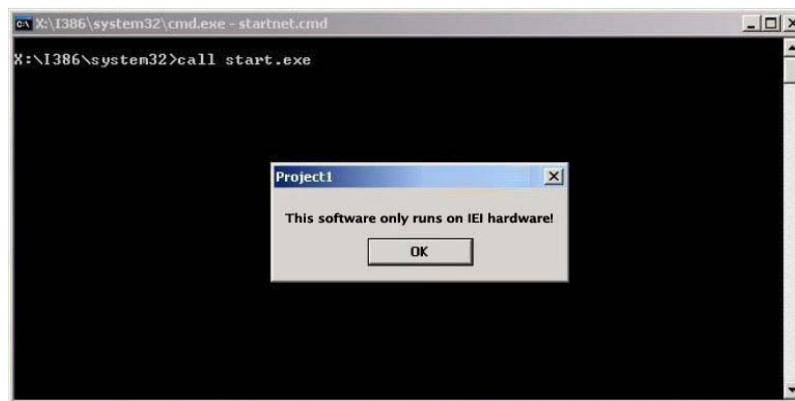

To create the system backup, the main storage device must be split into two partitions (three partitions for Linux). The first partition will be for the operating system, while the second partition will be invisible to the operating system and contain the backup made by the one key recovery software.

The partition created for recovery images must be big enough to contain both the factory default image and the user backup image. The size must be calculated before creating the

partitions. Please take the following table as a reference when calculating the size of the partition.

	OS	OS Image after Ghost	Compression Ratio
Windows® 7	7 GB	5 GB	70%
Windows® XPE	776 MB	560 MB	70%
Windows® CE 6.0	36 MB	28 MB	77%

**NOTE:**

Specialized tools are required to change the partition size if the operating system is already installed.

B.1.2 Supported Operating System

The recovery CD is compatible with both Microsoft Windows and Linux operating systems (OS). The supported OS versions are listed below.

- Microsoft Windows
 - Windows XP (Service Pack 2 or 3 required)
 - Windows Vista
 - Windows 7
 - Windows CE 5.0
 - Windows CE 6.0
 - Windows XP Embedded
- Linux
 - Fedora Core 12 (Constantine)
 - Fedora Core 11 (Leonidas)
 - Fedora Core 10 (Cambridge)
 - Fedora Core 8 (Werewolf)
 - Fedora Core 7 (Moonshine)
 - RedHat RHEL-5.4
 - RedHat 9 (Ghirke)

KINO-AQ870

- Ubuntu 8.10 (Intrepid)
- Ubuntu 7.10 (Gutsy)
- Ubuntu 6.10 (Edgy)
- Debian 5.0 (Lenny)
- Debian 4.0 (Etch)
- SuSe 11.2
- SuSe 10.3



NOTE:

Installing unsupported OS versions may cause the recovery tool to fail.

B.2 Setup Procedure for Windows

Prior to using the recovery tool to backup or restore, a few setup procedures are required.

Step 6: Hardware and BIOS setup (see **Section B.2.1**)

Step 7: Create partitions (see **Section B.2.2**)

Step 8: Install operating system, drivers and system applications (see **Section B.2.3**)

Step 9: Build the recovery partition (see **Section B.2.4**) or build the auto recovery partition (see **Section B.3**)

Step 10: Create factory default image (see **Section B.2.5**)

The detailed descriptions are described in the following sections.



NOTE:

The setup procedures described below are for Microsoft Windows operating system users. For Linux, most of the setup procedures are the same except for several steps described in **Section B.3**.

B.2.1 Hardware and BIOS Setup

- Step 1:** Make sure the system is powered off and unplugged.
- Step 2:** Install a hard drive or SSD in the system. An unformatted and unpartitioned disk is recommended.
- Step 3:** Connect an optical disk drive to the system and insert the recovery CD.
- Step 4:** Turn on the system.
- Step 5:** Press the <DELETE> key as soon as the system is turned on to enter the BIOS.
- Step 6:** Select the connected optical disk drive as the 1st boot device. (**Boot → Boot Device Priority → 1st Boot Device**).
- Step 7:** Save changes and restart the computer. Continue to the next section for instructions on partitioning the internal storage.

B.2.2 Create Partitions

To create the system backup, the main storage device must be split into two partitions (three partitions for Linux). The first partition will be for the operating system, while the second partition will be invisible to the operating system and contain the backup made by the one key recovery software.

- Step 1:** Put the recovery CD in the optical drive of the system.
- Step 2:** **Boot the system from recovery CD.** When prompted, press any key to boot from the recovery CD. It will take a while to launch the recovery tool. Please be patient!

KINO-AQ870

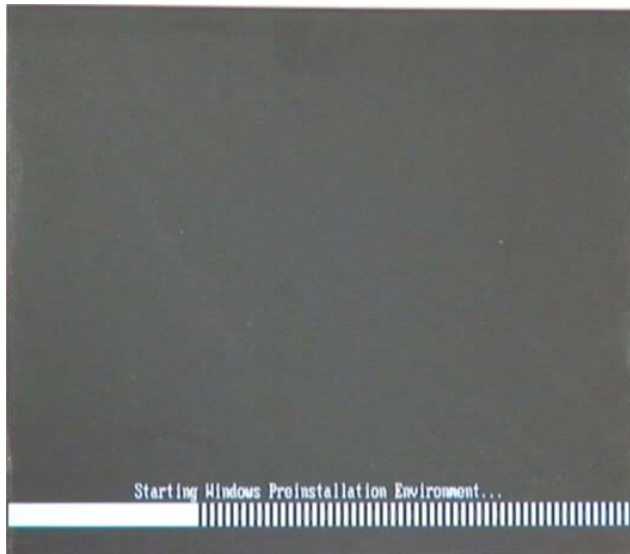

Figure B-2: Launching the Recovery Tool

Step 3: The recovery tool setup menu is shown as below.

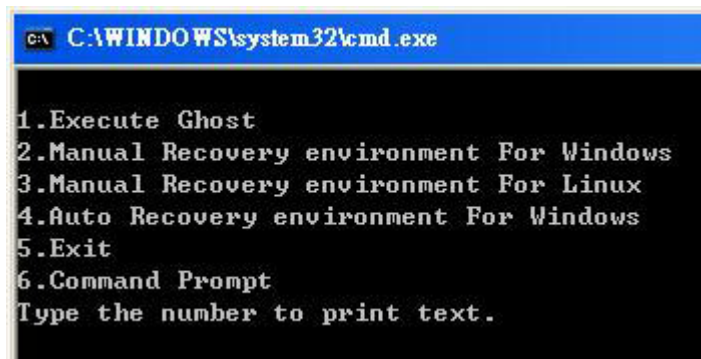
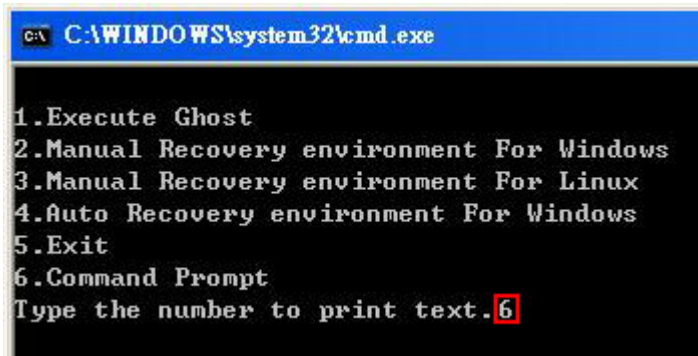

Figure B-3: Recovery Tool Setup Menu

Step 4: Press <6> then <Enter>.



```
C:\WINDOWS\system32\cmd.exe

1.Execute Ghost
2.Manual Recovery environment For Windows
3.Manual Recovery environment For Linux
4.Auto Recovery environment For Windows
5.Exit
6.Command Prompt
Type the number to print text. 6
```

Figure B-4: Command Prompt

Step 5: The command prompt window appears. Type the following commands (marked in red) to create two partitions. One is for the OS installation; the other is for saving recovery files and images which will be an invisible partition. (Press <Enter> after entering each line below)

```
system32>diskpart
DISKPART>list vol
DISKPART>sel disk 0
DISKPART>create part pri size= ____
DISKPART>assign letter=N
DISKPART>create part pri size= ____
DISKPART>assign letter=F
DISKPART>exit
system32>format N: /fs:ntfs /q /y
system32>format F: /fs:ntfs /q /v:Recovery /y
system32>exit
```

```

X:\I386\SYSTEM32\CMD.EXE
X:\I386\SYSTEM32>diskpart → Starts the Microsoft disk partitioning tool.

Microsoft DiskPart version 5.2.3790.1830
Copyright (C) 1999-2001 Microsoft Corporation.
On computer: MININT-JUC

DISKPART> list vol → Show partition information

   Volume ###  Ltr  Label          Fs          Type          Size         Status       Info
   -----  -  -  -  -  -  -  -  -  -
   Volume 0             X   CD_ROM        CDFS        DUD-ROM        405 MB     Healthy      Boot
   Volume 1             D                   FAT32     Removeable    3854 MB     Healthy

DISKPART> sel disk 0 → Select a disk
Disk 0 is now the selected disk.

DISKPART> create part pri size=2000 → Create partition 1 and assign a size.
                                     This partition is for OS installation.
DiskPart succeeded in creating the specified partition.

DISKPART> assign letter=N → Assign partition 1 a code name (N).
DiskPart successfully assigned the drive letter or mount point.

DISKPART> create part pri size=1800 → Create partition 2 and assign a size.
                                     This partition is for recovery images.
DiskPart succeeded in creating the specified partition.

DISKPART> assign letter=F → Assign partition 2 a code name (F).
DiskPart successfully assigned the drive letter or mount point.

DISKPART> exit → Exit diskpart

X:\I386\SYSTEM32>format n: /fs:ntfs /q /y → Format partition 1 (N) as NTFS format.
The type of the file system is RAW.
The new file system is NTFS.
QuickFormatting 2000M
Creating file system structures.
Format complete.
 2048254 KB total disk space.
 2035620 KB are available.

X:\I386\SYSTEM32>format f: /fs:ntfs /q /v:Recovery /y → Formate partition 2 (F) as NTFS formate and
                                                         name it as "Recovery".
The type of the file system is RAW.
The new file system is NTFS.
QuickFormatting 1804M
Creating file system structures.
Format complete.
 1847474 KB total disk space.
 1835860 KB are available.

X:\I386\SYSTEM32>exit → Exit Windows PE

```

Figure B-5: Partition Creation Commands

**NOTE:**

Use the following commands to check if the partitions were created successfully.

```
X:\I386\SYSTEM32>diskpart
Microsoft DiskPart version 5.2.3790.1830
Copyright (C) 1999-2001 Microsoft Corporation.
On computer: MININT-JUC
DISKPART> sel disk 0
Disk 0 is now the selected disk.
DISKPART> list part
  Partition ###  Type              Size      Offset
-----
  Partition 1    Primary           2000 MB   32 KB
  Partition 2    Primary           1804 MB  2000 MB
DISKPART> exit
```

Step 6: Press any key to exit the recovery tool and automatically reboot the system.

Please continue to the following procedure: Build the Recovery Partition.

B.2.3 Install Operating System, Drivers and Applications

Install the operating system onto the unlabelled partition. The partition labeled "Recovery" is for use by the system recovery tool and should not be used for installing the operating system or any applications.

**NOTE:**

The operating system installation program may offer to reformat the chosen partition. DO NOT format the partition again. The partition has already been formatted and is ready for installing the new operating system.

To install the operating system, insert the operating system installation CD into the optical drive. Restart the computer and follow the installation instructions.

KINO-AQ870

B.2.4 Building the Recovery Partition

- Step 1:** Put the recover CD in the optical drive.
- Step 2:** Start the system.
- Step 3:** **Boot the system from the recovery CD.** When prompted, press any key to boot from the recovery CD. It will take a while to launch the recovery tool. Please be patient!

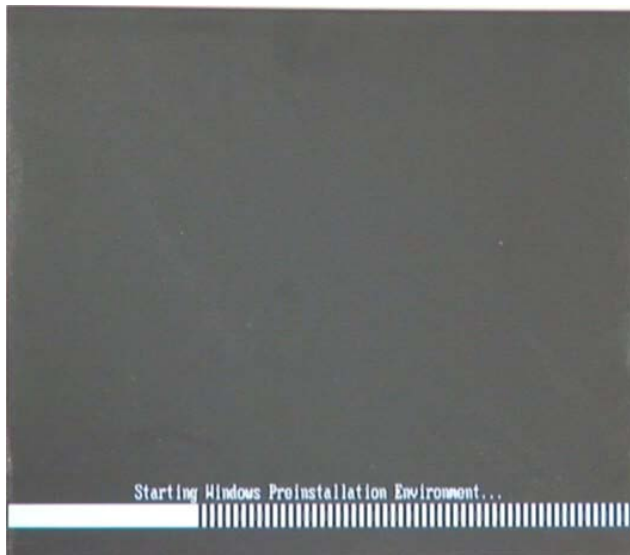

Figure B-6: Launching the Recovery Tool

- Step 4:** When the recovery tool setup menu appears, press <2> then <Enter>.

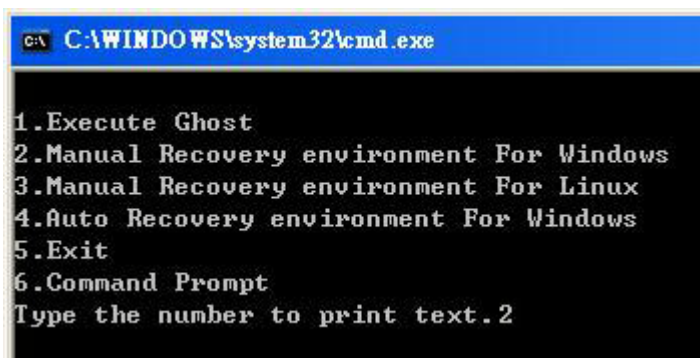

Figure B-7: Manual Recovery Environment for Windows

Step 5: The Symantec Ghost window appears and starts configuring the system to build a recovery partition. In this process the partition created for recovery files in **Section B.2.2** is hidden and the recovery tool is saved in this partition.

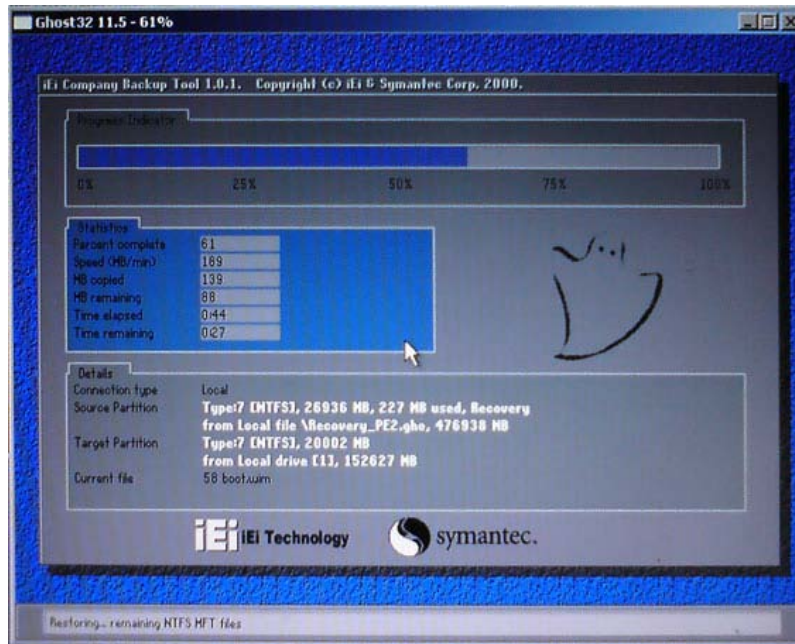

Figure B-8: Building the Recovery Partition

Step 6: After completing the system configuration, press any key in the following window to reboot the system.

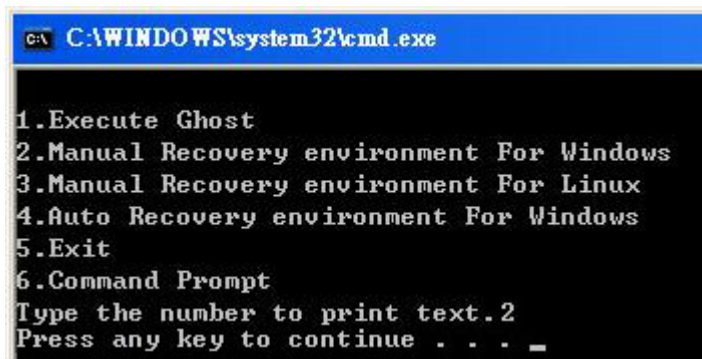

Figure B-9: Press Any Key to Continue

Step 7: Eject the recovery CD.

KINO-AQ870

B.2.5 Create Factory Default Image



NOTE:

Before creating the factory default image, please configure the system to a factory default environment, including driver and application installations.

To create a factory default image, please follow the steps below.

Step 1: Turn on the system. When the following screen displays (**Figure B-10**), press the <F3> key to access the recovery tool. The message will display for 10 seconds, please press F3 before the system boots into the operating system.

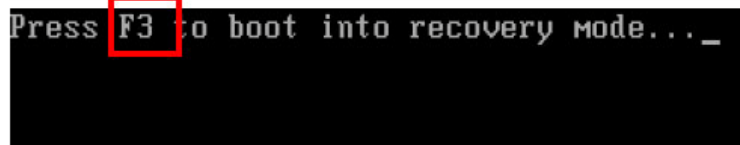

Figure B-10: Press F3 to Boot into Recovery Mode

Step 2: The recovery tool menu appears. Type <4> and press <Enter>. (**Figure B-11**)

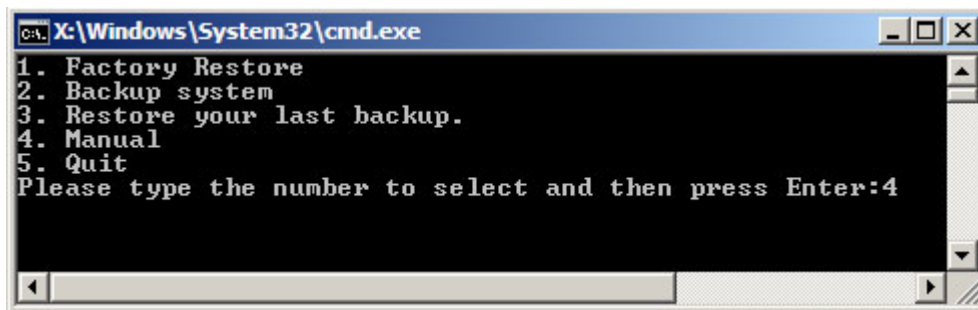

Figure B-11: Recovery Tool Menu

Step 3: The About Symantec Ghost window appears. Click **OK** button to continue.

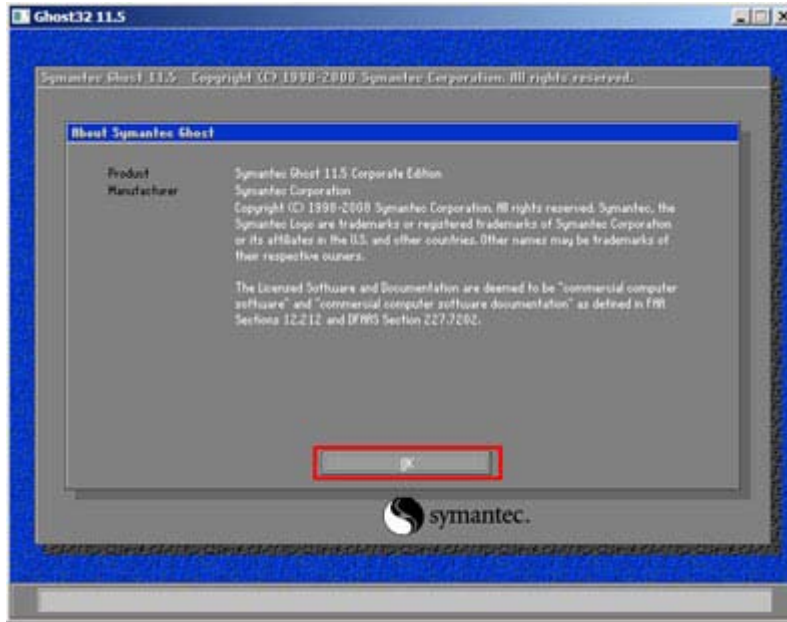

Figure B-12: About Symantec Ghost Window

Step 4: Use mouse to navigate to the option shown below (Figure B-13).

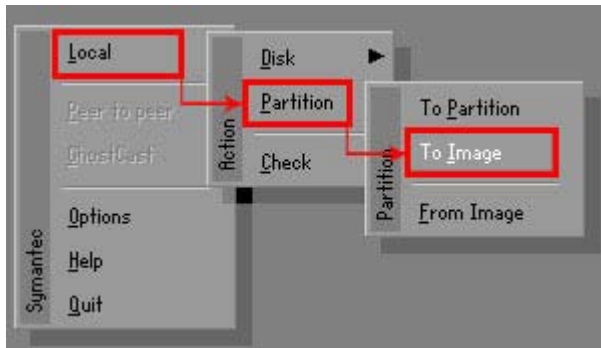

Figure B-13: Symantec Ghost Path

Step 5: Select the local source drive (Drive 1) as shown in Figure B-14. Then click OK.

KINO-AQ870

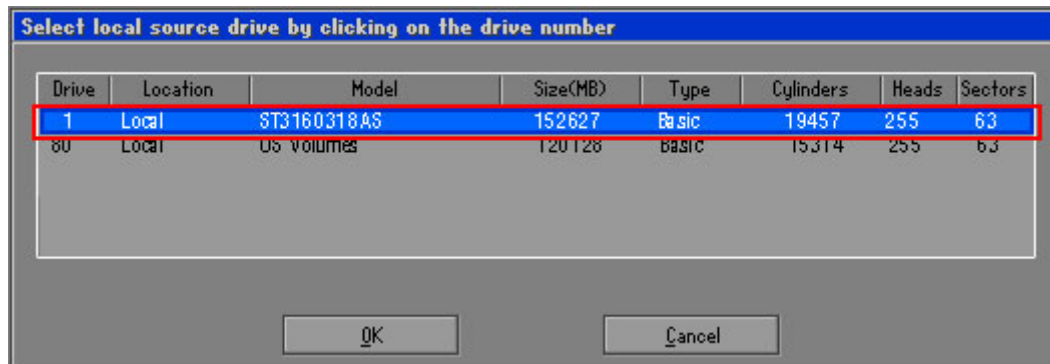

Figure B-14: Select a Local Source Drive

Step 6: Select a source partition (Part 1) from basic drive as shown in **Figure B-15**. Then click OK.

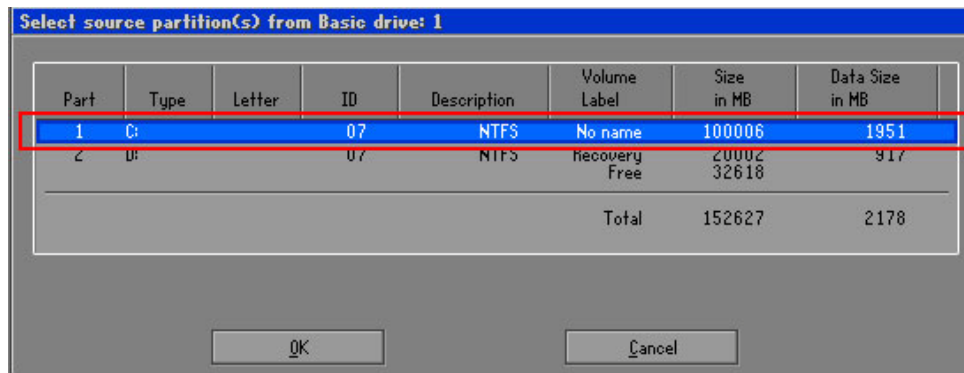

Figure B-15: Select a Source Partition from Basic Drive

Step 7: Select **1.2: [Recovery] NTFS drive** and enter a file name called **iei** (**Figure B-16**). Click **Save**. The factory default image will then be saved in the selected recovery drive and named **IEI.GHO**.



WARNING:

The file name of the factory default image must be **iei.GHO**.

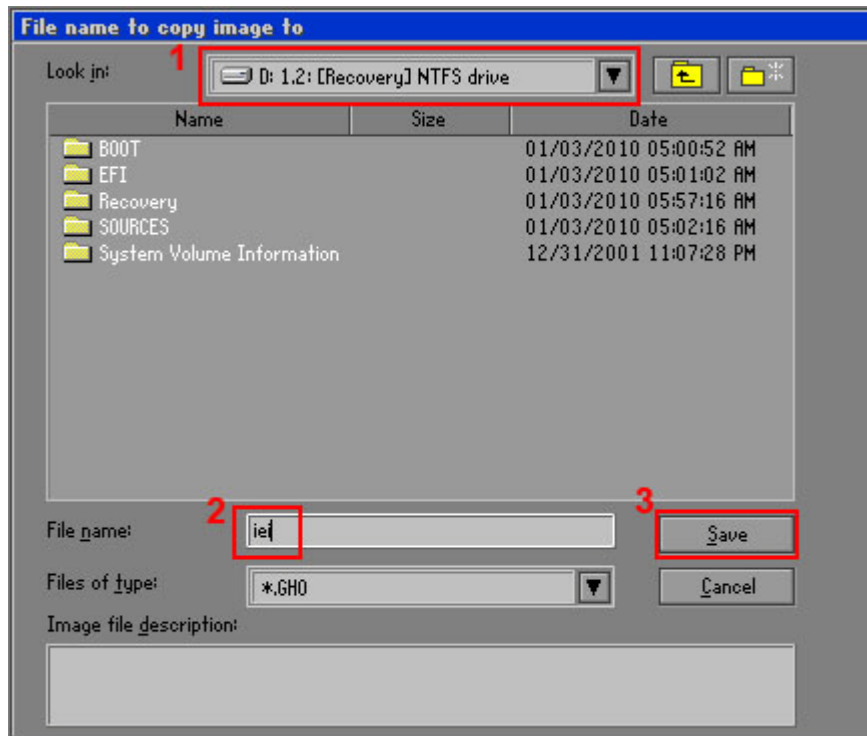

Figure B-16: File Name to Copy Image to

Step 8: When the Compress Image screen in **Figure B-17** prompts, click **High** to make the image file smaller.

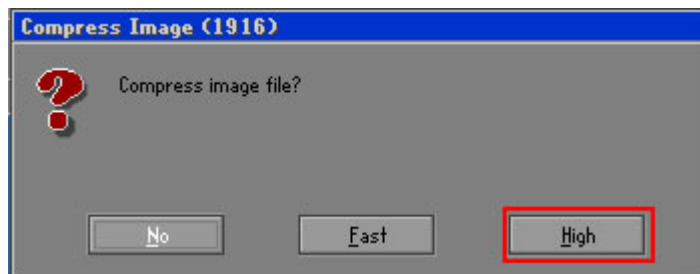

Figure B-17: Compress Image

KINO-AQ870

Step 9: The Proceed with partition image creation window appears, click **Yes** to continue.

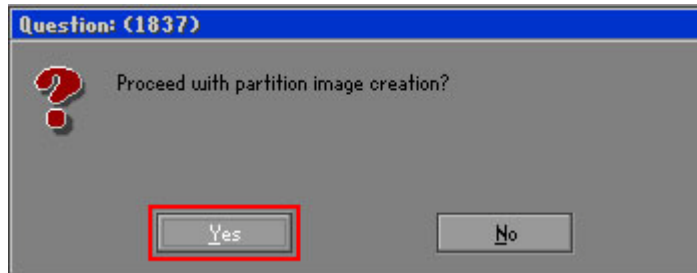

Figure B-18: Image Creation Confirmation

Step 10: The Symantec Ghost starts to create the factory default image (**Figure B-19**).

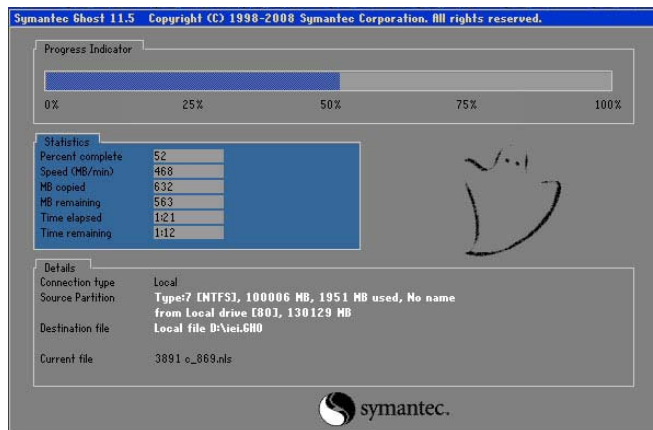

Figure B-19: Image Creation Complete

Step 11: When the image creation completes, a screen prompts as shown in **Figure B-20**.

Click **Continue** and close the Ghost window to exit the program.

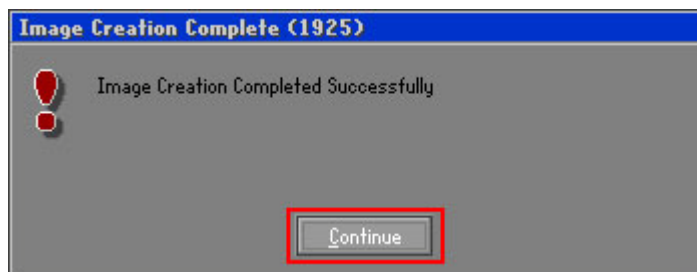
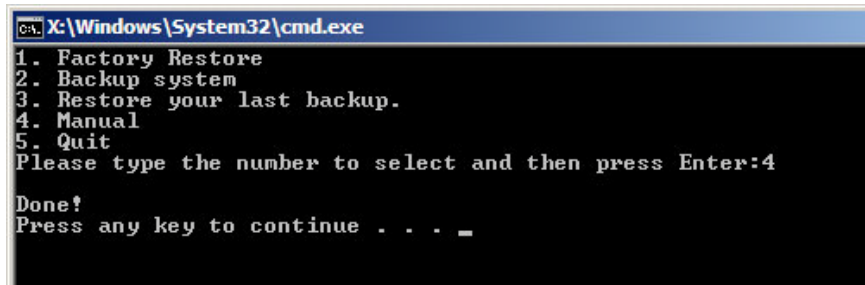

Figure B-20: Image Creation Complete

Step 12: The recovery tool main menu window is shown as below. Press any key to reboot the system.



```
C:\Windows\System32\cmd.exe
1. Factory Restore
2. Backup system
3. Restore your last backup.
4. Manual
5. Quit
Please type the number to select and then press Enter:4
Done!
Press any key to continue . . . _
```

Figure B-21: Press Any Key to Continue

B.3 Auto Recovery Setup Procedure

The auto recovery function allows a system to automatically restore from the factory default image after encountering a Blue Screen of Death (BSoD) or a hang for around 10 minutes. To use the auto recovery function, follow the steps described in the following sections.



CAUTION:

The setup procedure may include a step to create a factory default image. It is suggested to configure the system to a factory default environment before the configuration, including driver and application installations.

Step 1: Follow the steps described in **Section B.2.1 ~ Section B.2.3** to setup BIOS, create partitions and install operating system.

Step 2: Install the auto recovery utility into the system by double clicking the **Utility/AUTORECOVERY-SETUP.exe** in the One Key Recovery CD. This utility **MUST** be installed in the system, otherwise, the system will automatically restore from the factory default image every ten (10) minutes.

KINO-AQ870



Figure B-22: Auto Recovery Utility

Step 3: Reboot the system from the recovery CD. When prompted, press any key to boot from the recovery CD. It will take a while to launch the recovery tool. Please be patient!

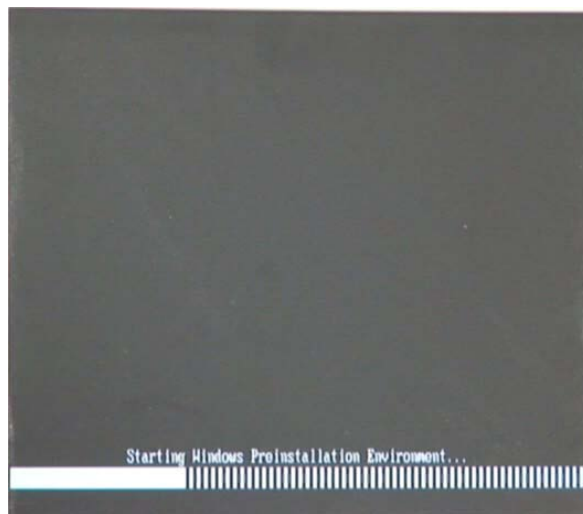

Figure B-23: Launching the Recovery Tool

Step 4: When the recovery tool setup menu appears, press <4> then <Enter>.

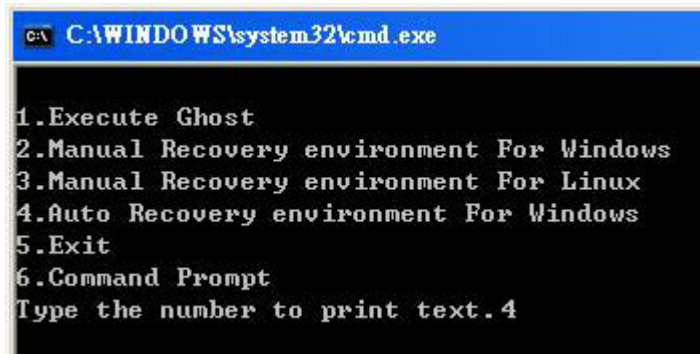

Figure B-24: Auto Recovery Environment for Windows

Step 5: The Symantec Ghost window appears and starts configuring the system to build an auto recovery partition. In this process the partition created for recovery files in **Section B.2.2** is hidden and the auto recovery tool is saved in this partition.

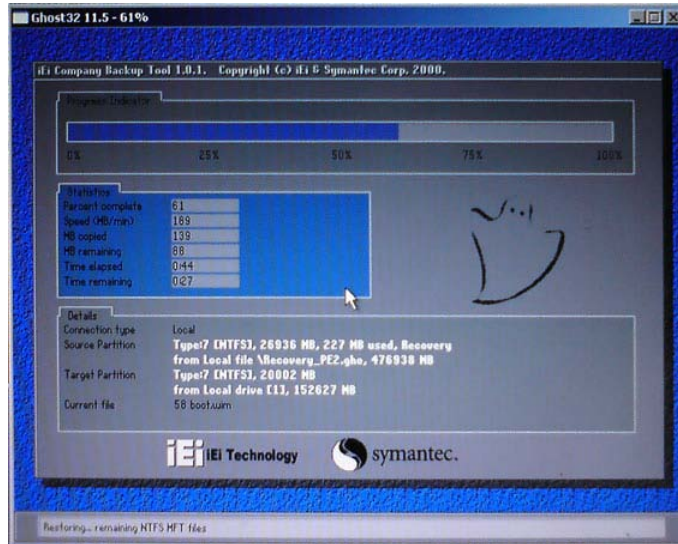

Figure B-25: Building the Auto Recovery Partition

Step 6: After completing the system configuration, the following message prompts to confirm whether to create a factory default image. Type **Y** to have the system create a factory default image automatically. Type **N** within 6 seconds to skip this process (The default option is YES). It is suggested to choose YES for this option.



Figure B-26: Factory Default Image Confirmation

KINO-AQ870

Step 7: The Symantec Ghost starts to create the factory default image (**Figure B-27**).

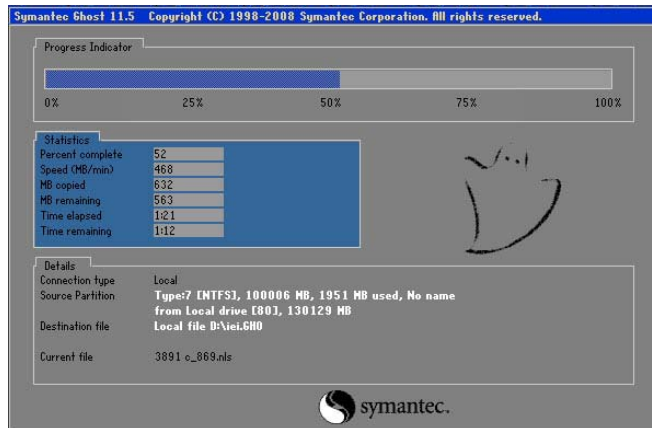

Figure B-27: Image Creation Complete

Step 8: After completing the system configuration, press any key in the following window to restart the system.

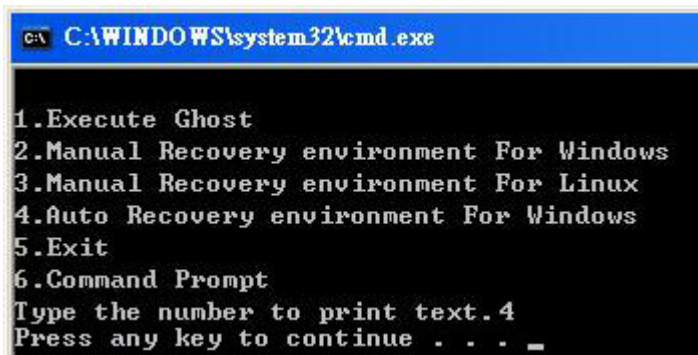
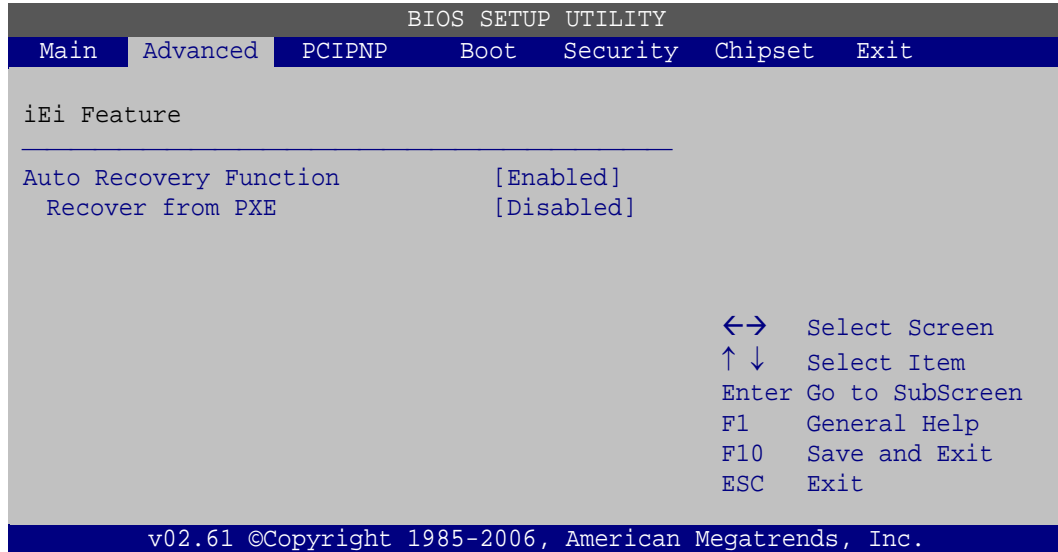

Figure B-28: Press any key to continue

Step 9: Eject the One Key Recovery CD and restart the system.

Step 10: Press the <DELETE> key as soon as the system is turned on to enter the BIOS.

Step 11: Enable the Auto Recovery Function option (**Advanced** → **iEi Feature** → **Auto Recovery Function**).



BIOS Menu 26: IEI Feature

Step 12: Save changes and restart the system. If the system encounters a Blue Screen of Death (BSoD) or a hang for around 10 minutes, it will automatically restore from the factory default image.



CAUTION:

The auto recovery function can only apply on a Microsoft Windows system running the following OS versions:

- Windows XP
- Windows Vista
- Windows 7

B.4 Setup Procedure for Linux

The initial setup procedure for Linux system is mostly the same with the procedure for Microsoft Windows. Please follow the steps below to setup recovery tool for Linux OS.

Step 1: **Hardware and BIOS setup.** Refer to **Section B.2.1.**

KINO-AQ870

Step 2: Install Linux operating system. Make sure to install GRUB (v0.97 or earlier) MBR type and Ext3 partition type. Leave enough space on the hard drive to create the recover partition later.

**NOTE:**

If the Linux OS is not installed with GRUB (v0.97 or earlier) and Ext3, the Symantec Ghost may not function properly.

While installing Linux OS, please create two partitions:

- Partition 1: /
- Partition 2: **SWAP**

**NOTE:**

Please reserve enough space for partition 3 for saving recovery images.

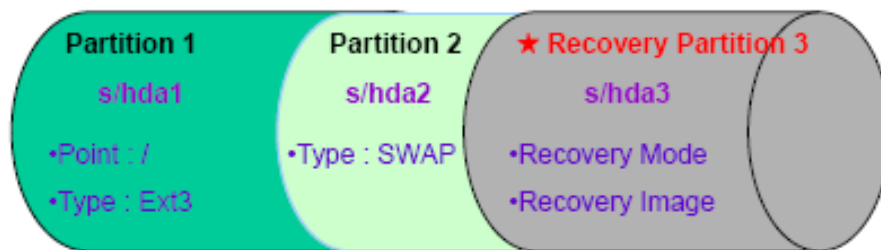

Figure B-29: Partitions for Linux

Step 3: Create a recovery partition. Insert the recovery CD into the optical disk drive. Follow **Step 1 ~ Step 3** described in **Section B.2.2**. Then type the following commands (marked in red) to create a partition for recovery images.

```
system32>diskpart
```

```
DISKPART>list vol
```

```
DISKPART>sel disk 0
```

```
DISKPART>create part pri size= ____
```

```
DISKPART>assign letter=N
```

```
DISKPART>exit
```

```
system32>format N: /fs:ntfs /q /v:Recovery /y
```

```
system32>exit
```

Step 4: Build the recovery partition. Press any key to boot from the recovery CD. It will take a while to launch the recovery tool. Please be patient. When the recovery tool setup menu appears, type <3> and press <Enter> (**Figure B-30**). The Symantec Ghost window appears and starts configuring the system to build a recovery partition. After completing the system configuration, press any key to reboot the system. Eject the recovery CD.

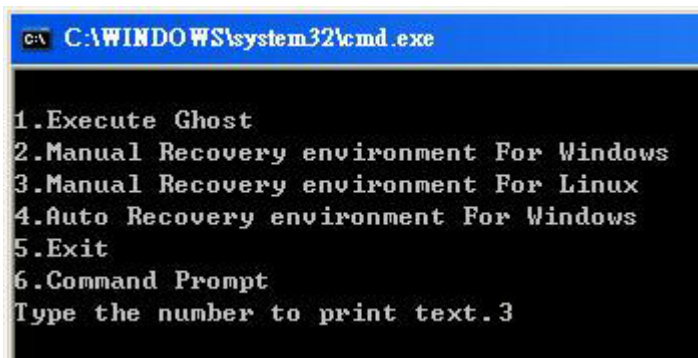
A screenshot of a Windows command prompt window. The title bar reads "C:\WINDOWS\system32\cmd.exe". The command prompt displays a menu with the following options:

```
1. Execute Ghost
2. Manual Recovery environment For Windows
3. Manual Recovery environment For Linux
4. Auto Recovery environment For Windows
5. Exit
6. Command Prompt
Type the number to print text.3
```

Figure B-30: Manual Recovery Environment for Linux

Step 5: Access the recovery tool main menu by modifying the “menu.lst”. To first access the recovery tool main menu, the menu.lst must be modified. In Linux, enter Administrator (root). When prompt appears, type:

```
cd /boot/grub
```

```
vi menu.lst
```

KINO-AQ870

```
Fedora release 9 (Sulphur)
Kernel 2.6.25-14.fc9.i686 on an i686 (tty2)

localhost login: root
Password:
[root@localhost ~]# cd /boot/grub/
[root@localhost grub]# vi menu.lst _
```

Figure B-31: Access menu.lst in Linux (Text Mode)

Step 6: Modify the menu.lst as shown below.

```
#boot=/dev/sda
default=0
timeout=10 ← Modify timeout=10
splashimage=(hd0,0)/grub/splash.xpm.gz
hiddenmenu
title Fedora (2.6.25-14.fc9.i686)
    root (hd0,0)
    kernel /vmlinuz-2.6.25-14.fc9.i686 ro root=UUID=10f1acda
    ac38b5c78910 rhgb quiet
    initrd /initrd-2.6.25-14.fc9.i686.img

title Recovery Partition
root (hd0,2)
makeactive ← Type command
chainloader +1
```

- Type command:
title Recovery Partition
root (hd0,2)
makeactive
chainloader +1

Step 7: The recovery tool menu appears. (Figure B-32)

```
1. Factory Restore
2. Backup system
3. Restore your last backup.
4. Manual
5. Quit
Please type the number to select and then press Enter:
```

Figure B-32: Recovery Tool Menu

Step 8: Create a factory default image. Follow Step 2 ~ Step 12 described in Section B.2.5 to create a factory default image.

B.5 Recovery Tool Functions

After completing the initial setup procedures as described above, users can access the recovery tool by pressing <F3> while booting up the system. However, if the setup procedure in Section B.3 has been completed and the auto recovery function is enabled, the system will automatically restore from the factory default image without pressing the F3 key. The recovery tool main menu is shown below.

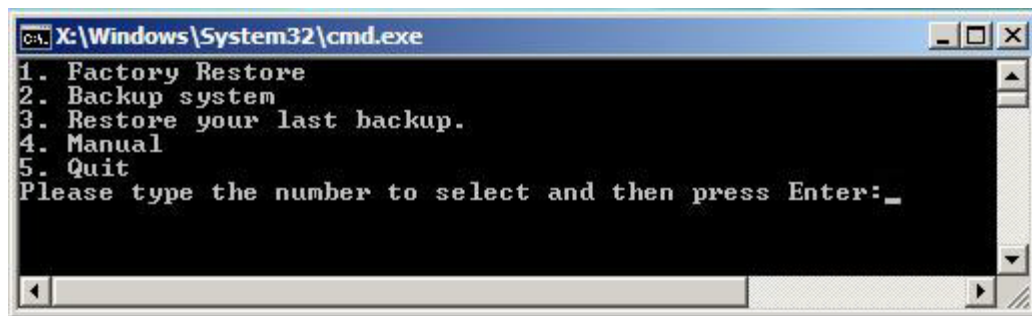

Figure B-33: Recovery Tool Main Menu

The recovery tool has several functions including:

1. **Factory Restore:** Restore the factory default image (iei.GHO) created in Section B.2.5.
2. **Backup system:** Create a system backup image (iei_user.GHO) which will be saved in the hidden partition.
3. **Restore your last backup:** Restore the last system backup image
4. **Manual:** Enter the Symantec Ghost window to configure manually.
5. **Quit:** Exit the recovery tool and restart the system.



WARNING:

Please do not turn off the system power during the process of system recovery or backup.

KINO-AQ870

**WARNING:**

All data in the system will be deleted during the system recovery. Please backup the system files before restoring the system (either Factory Restore or Restore Backup).

B.5.1 Factory Restore

To restore the factory default image, please follow the steps below.

Step 1: Type <1> and press <Enter> in the main menu.

Step 2: The Symantec Ghost window appears and starts to restore the factory default. A factory default image called **iei.GHO** is created in the hidden Recovery partition.

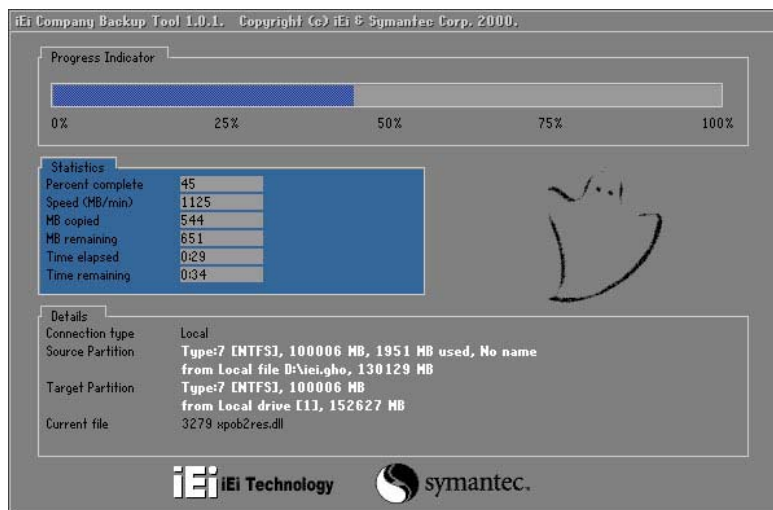

Figure B-34: Restore Factory Default

Step 3: The screen shown in **Figure B-35** appears when completed. Press any key to reboot the system.

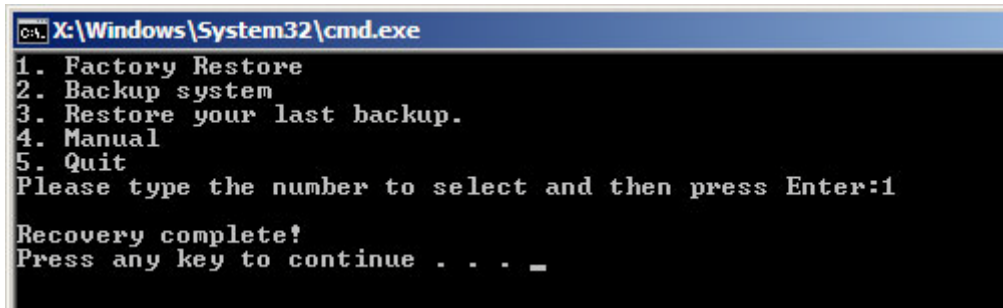

Figure B-35: Recovery Complete Window

B.5.2 Backup System

To backup the system, please follow the steps below.

Step 1: Type <2> and press <Enter> in the main menu.

Step 2: The Symantec Ghost window appears and starts to backup the system. A backup image called **iei_user.GHO** is created in the hidden Recovery partition.

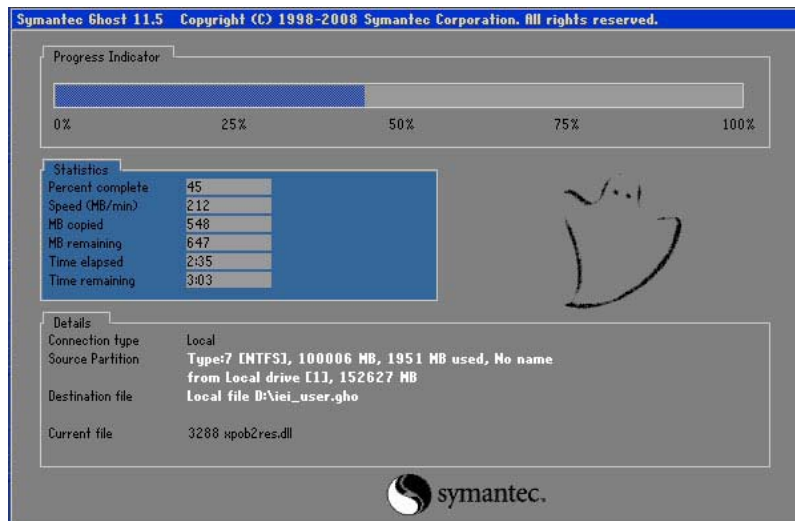

Figure B-36: Backup System

Step 3: The screen shown in **Figure B-37** appears when system backup is complete. Press any key to reboot the system.

KINO-AQ870

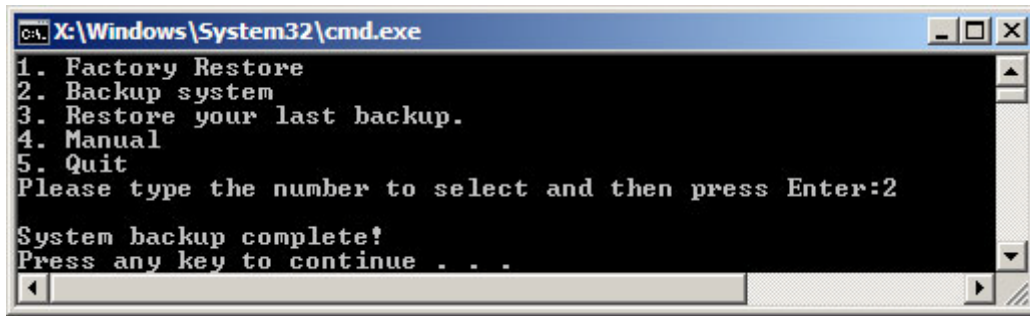

Figure B-37: System Backup Complete Window

B.5.3 Restore Your Last Backup

To restore the last system backup, please follow the steps below.

Step 1: Type <3> and press <Enter> in the main menu.

Step 2: The Symantec Ghost window appears and starts to restore the last backup image (iei_user.GHO).

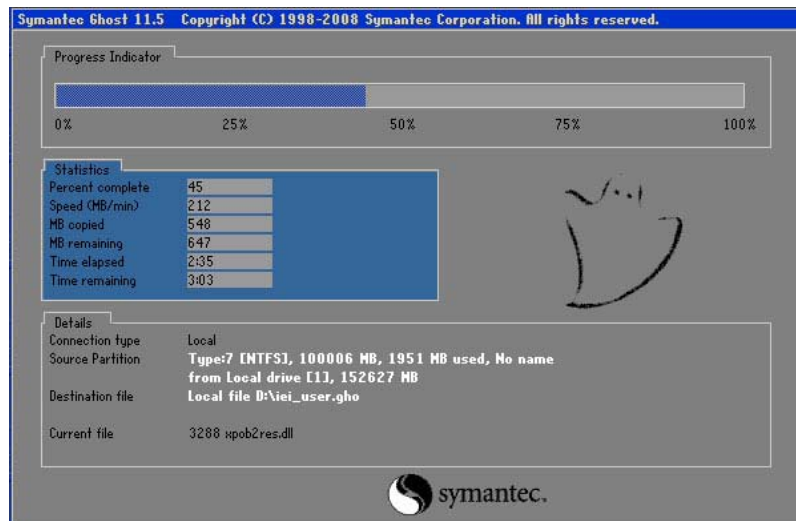
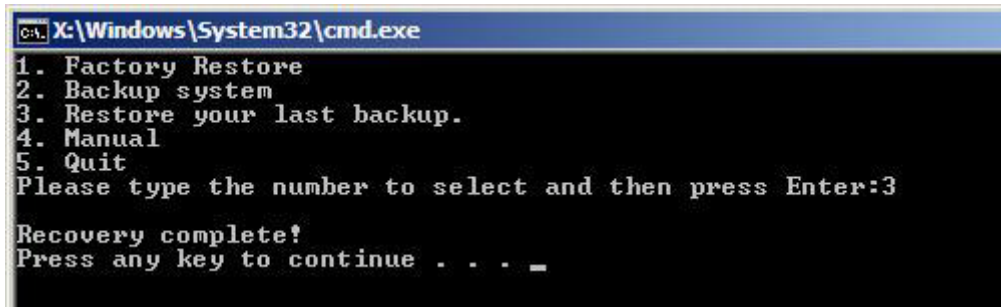

Figure B-38: Restore Backup

Step 3: The screen shown in **Figure B-39** appears when backup recovery is complete. Press any key to reboot the system.



```
C:\X:\Windows\System32\cmd.exe
1. Factory Restore
2. Backup system
3. Restore your last backup.
4. Manual
5. Quit
Please type the number to select and then press Enter:3
Recovery complete!
Press any key to continue . . . _
```

Figure B-39: Restore System Backup Complete Window

B.5.4 Manual

To restore the last system backup, please follow the steps below.

Step 4: Type <4> and press <Enter> in the main menu.

Step 5: The Symantec Ghost window appears. Use the Ghost program to backup or recover the system manually.

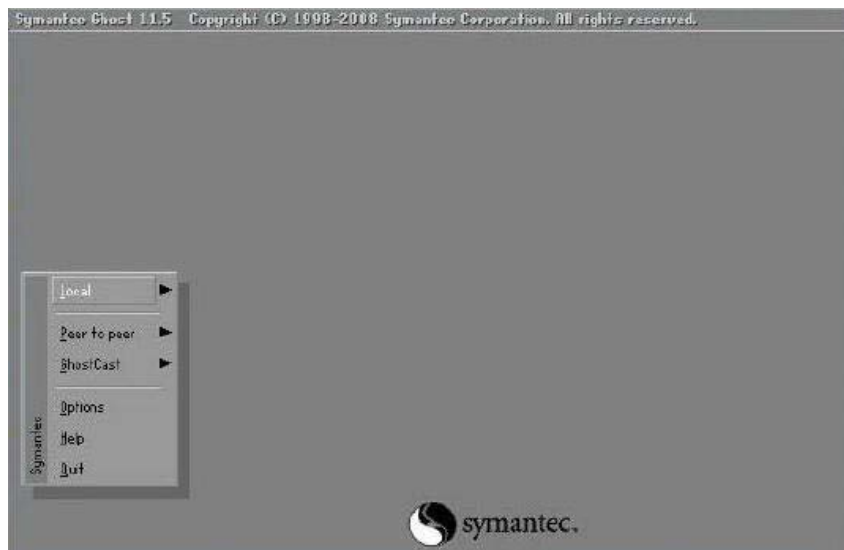

Figure B-40: Symantec Ghost Window

Step 6: When backup or recovery is completed, press any key to reboot the system.

KINO-AQ870

B.6 Restore Systems from a Linux Server through LAN

The One Key Recovery allows a client system to automatically restore to a factory default image saved in a Linux system (the server) through LAN connectivity after encountering a Blue Screen of Death (BSoD) or a hang for around 10 minutes. To be able to use this function, the client system and the Linux system MUST reside in the same domain.

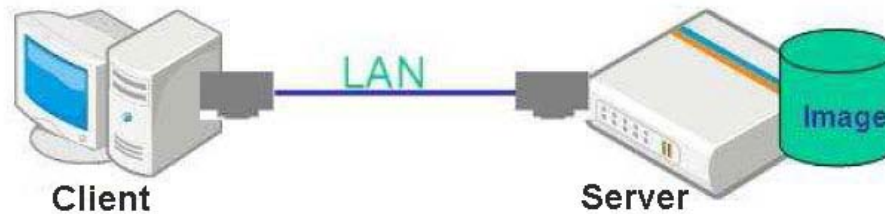

NOTE:

The supported client OS includes:

- Windows 2000
- Windows XP
- Windows Vista
- Windows 7
- Windows CE
- Windows XP Embedded

Prior to restoring client systems from a Linux server, a few setup procedures are required.

Step 1: Configure DHCP server settings

Step 2: Configure TFTP settings

Step 3: Configure One Key Recovery server settings

Step 4: Start DHCP, TFTP and HTTP

Step 5: Create a shared directory

Step 6: Setup a client system for auto recovery

The detailed descriptions are described in the following sections. In this document, two types of Linux OS are used as examples to explain the configuration process – CentOS 5.5 (Kernel 2.6.18) and Debian 5.0.7 (Kernel 2.6.26).

B.6.1 Configure DHCP Server Settings

Step 1: Install the DHCP

`#yum install dhcp` (CentOS, commands marked in red)

`#apt-get install dhcp3-server` (Debian, commands marked in blue)

Step 2: Confirm the operating system default settings: dhcpd.conf.

CentOS

Use the following command to show the DHCP server sample location:

`#vi /etc/dhcpd.conf`

The DHCP server sample location is shown as below:

```
# DHCP Server Configuration file.
# see /usr/share/doc/dhcp*/dhcpd.conf.sample
#
```

Use the following command to copy the DHCP server sample to etc/dhcpd.conf:

`#cp /usr/share/doc/dhcp-3.0.5/dhcpd.conf.sample /etc/dhcpd.conf`

`#vi /etc/dhcpd.conf`

```
ddns-update-style interim;
ignore client-updates;

subnet 192.168.0.0 netmask 255.255.255.0 {
# --- default gateway
    option routers          192.168.0.2;
    option subnet-mask     255.255.255.0;

    option nis-domain      "domain.org";
    option domain-name     "domain.org";
    option domain-name-servers 192.168.0.1;
    next-server 192.168.0.6;
    filename "pxelinux.0";
    option time-offset     -18000; # Eastern Standard Time
    option ntp-servers     192.168.1.1;
    #
```

Debian

`#vi /etc/dhcpd.conf`

Edit “/etc/dhcpd.conf” for your environment. For example, add

`next-server PXE server IP address;`

KINO-AQ870

```
filename "pxelinux.0";
```

```
ddns-update-style interim;
ignore client-updates;

subnet 192.168.0.0 netmask 255.255.255.0 {

# --- default gateway
    option routers                192.168.0.2;
    option subnet-mask            255.255.255.0;

    option nis-domain             "domain.org";
    option domain-name            "domain.org";
    option domain-name-servers    192.168.0.1;
    next-server 192.168.0.6;
    filename "pxelinux.0";
    option time-offset            -18000; # Eastern Standard Time
    option ntp-servers            192.168.1.1;
}
```

B.6.2 Configure TFTP Settings

Step 1: Install the tftp, httpd and syslinux.

```
#yum install tftp-server httpd syslinux (CentOS)
```

```
#apt-get install tftpd-hpa xinetd syslinux (Debian)
```

Step 2: Enable the TFTP server by editing the "/etc/xinetd.d/tftp" file and make it use the remap file. The "-vvv" is optional but it could definitely help on getting more information while running the remap file. For example:

CentOS

```
#vi /etc/xinetd.d/tftp
```

Modify:

```
disable = no
```

```
server_args = -s /tftpboot -m /tftpboot/tftpd.remap -vvv_
```

```
socket_type      = dgram
protocol         = udp
wait            = yes
user            = root
server          = /usr/sbin/in.tftpd
server_args     = -s /tftpboot -m /tftpboot/tftpd.remap -vvv
disable         = no
per_source      = 11
cps             = 100 2
flags           = IPv4
```

Debian

Replace the TFTP settings from “inetd” to “xinetd” and annotate the “inetd” by adding “#”.

`#vi /etc/inetd.conf`

Modify: `#tftp dgram udp wait root /usr/sbin.....` (as shown below)

```
#:BOOT: TFTP service is provided primarily for booting. Most sites
#      run this only on machines acting as "boot servers."
#tftp  dgram  udp   wait  root  /usr/sbin/in.tftpd /usr/sbin/in.tftpd -s
/var/lib/tftpboot
```

`#vi /etc/xinetd.d/tftp`

```
socket_type      = dgram
protocol        = udp
wait            = yes
user           = root
server         = /usr/sbin/in.tftpd
server_args    = -s /tftpboot -m /tftpboot/tftpd.remap -vvv
disable        = no
per_source     = 11
cps            = 100 2
flags          = IPv4
```

B.6.3 Configure One Key Recovery Server Settings

Step 1: Copy the **Utility/RECOVERYR10.TAR.BZ2** package from the One Key Recovery CD to the system (server side).



Step 2: Extract the recovery package to /.

```
#cp RecoveryR10.tar.bz2 /
#cd /
#tar -xvjf RecoveryR10.tar.bz2
```

Step 3: Copy “pxelinux.0” from “syslinux” and install to “tftpboot”.

```
#cp /usr/lib/syslinux/pxelinux.0 /tftpboot/
```

KINO-AQ870

B.6.4 Start the DHCP, TFTP and HTTP

Start the DHCP, TFTP and HTTP. For example:

CentOS

```
#service xinetd restart
```

```
#service httpd restart
```

```
#service dhcpd restart
```

Debian

```
#/etc/init.d/xinetd reload
```

```
#/etc/init.d/xinetd restart
```

```
#/etc/init.d/dhcp3-server restart
```

B.6.5 Create Shared Directory

Step 1: Install the samba.

```
#yum install samba
```

Step 2: Create a shared directory for the factory default image.

```
#mkdir /share
```

```
#cd /share
```

```
#mkdir /image
```

```
#cp iei.gho /image
```



WARNING:

The file name of the factory default image must be **iei.gho**.

Step 3: Confirm the operating system default settings: smb.conf.

```
#vi /etc/samba/smb.conf
```

Modify:

[image]

comment = One Key Recovery

path = /share/image

browseable = yes

writable = yes

public = yes

create mask = 0644

directory mask = 0755

Step 4: Edit "/etc/samba/smb.conf" for your environment. For example:

```
# "security = user" is always a good idea. This will require a Unix account
# in this server for every user accessing the server. See
# /usr/share/doc/samba-doc/htmldocs/Samba3-HOWTO/ServerType.html
# in the samba-doc package for details.
security = share
```

```
[image]
comment = One Key Recovery
path = /share/image
browseable = yes
writable = yes
public = yes
create mask = 0644
directory mask = 0755
```

Step 5: Modify the hostname

```
#vi /etc/hostname
```

Modify: RecoveryServer

```
RecoveryServer
```

B.6.6 Setup a Client System for Auto Recovery

Step 1: Configure the following BIOS options of the client system.

Advanced → iEi Feature → Auto Recovery Function → **Enabled**

Advanced → iEi Feature → Recover from PXE → **Enabled**

Boot → Launch PXE OpROM → **Enabled**

KINO-AQ870

Step 2: Continue to configure the **Boot Option Priorities** BIOS option of the client system:

Boot Option #1 → remain the default setting to boot from the original OS.

Boot Option #2 → select the boot from LAN option.

Step 3: Save changes and exit BIOS menu.

Exit → **Save Changes and Exit**

Step 4: Install the auto recovery utility into the system by double clicking the **Utility/AUTORECOVERY-SETUP.exe** in the One Key Recovery CD. This utility **MUST** be installed in the system, otherwise, the system will automatically restore from the factory default image every ten (10) minutes.



Step 5: Restart the client system from LAN. If the system encounters a Blue Screen of Death (BSoD) or a hang for around 10 minutes, it will automatically restore from the factory default image. The following screens will show when the system starts auto recovering.

```
Realtek PCIe GBE Family Controller Series v2.35 (06/14/10)
CLIENT MAC ADDR: 00 18 7D 13 E6 89  GUID: 00020003-0004-0005-0006-0007000000
DHCP . ./
```

```

My IP address seems to be C0A80009 192.168.0.9
ip=192.168.0.9:192.168.0.8:192.168.0.2:255.255.255.0
TFTP prefix:
Trying to load: pxelinux.cfg/00020003-0004-0005-0006-000700080009
Trying to load: pxelinux.cfg/01-00-18-7d-13-e6-89
Trying to load: pxelinux.cfg/C0A80009
Trying to load: pxelinux.cfg/C0A8000
Trying to load: pxelinux.cfg/C0A800
Trying to load: pxelinux.cfg/C0A80
Trying to load: pxelinux.cfg/C0A8
Trying to load: pxelinux.cfg/C0A
Trying to load: pxelinux.cfg/C0
Trying to load: pxelinux.cfg/C
Trying to load: pxelinux.cfg/default
boot:
    
```

```

Windows is loading files...

IP: 192.168.0.8, File: \Boot\WinPE.wim
    
```

Symantec Ghost 11.5 Copyright (C) 1998-2008 Symantec Corporation. All rights reserved.

Progress Indicator: 50%

Statistics	
Percent complete	52
Speed (MB/min)	468
MB copied	632
MB remaining	563
Time elapsed	1:21
Time remaining	1:12

Details:

Connection type	Local
Source Partition	Type:7 [NTFS], 100006 MB, 1951 MB used, No name from Local drive [80], 130129 MB
Destination file	Local file D:\iei.GHO
Current file	3891 e_869.nls

symantec.



NOTE:

A firewall or a SELinux is not in use in the whole setup process. If there is a firewall or a SELinux protecting the system, modify the configuration information to accommodate them.

KINO-AQ870

B.7 Other Information

B.7.1 Using AHCI Mode or ALi M5283 / VIA VT6421A Controller

When the system uses AHCI mode or some specific SATA controllers such as ALi M5283 or VIA VT6421A, the SATA RAID/AHCI driver must be installed before using one key recovery. Please follow the steps below to install the SATA RAID/AHCI driver.

Step 1: Copy the SATA RAID/AHCI driver to a floppy disk and insert the floppy disk into a USB floppy disk drive. The SATA RAID/AHCI driver must be especially designed for the on-board SATA controller.

Step 2: Connect the USB floppy disk drive to the system.

Step 3: Insert the One Key Recovery CD into the system and boot the system from the CD.

Step 4: When launching the recovery tool, press <F6>.

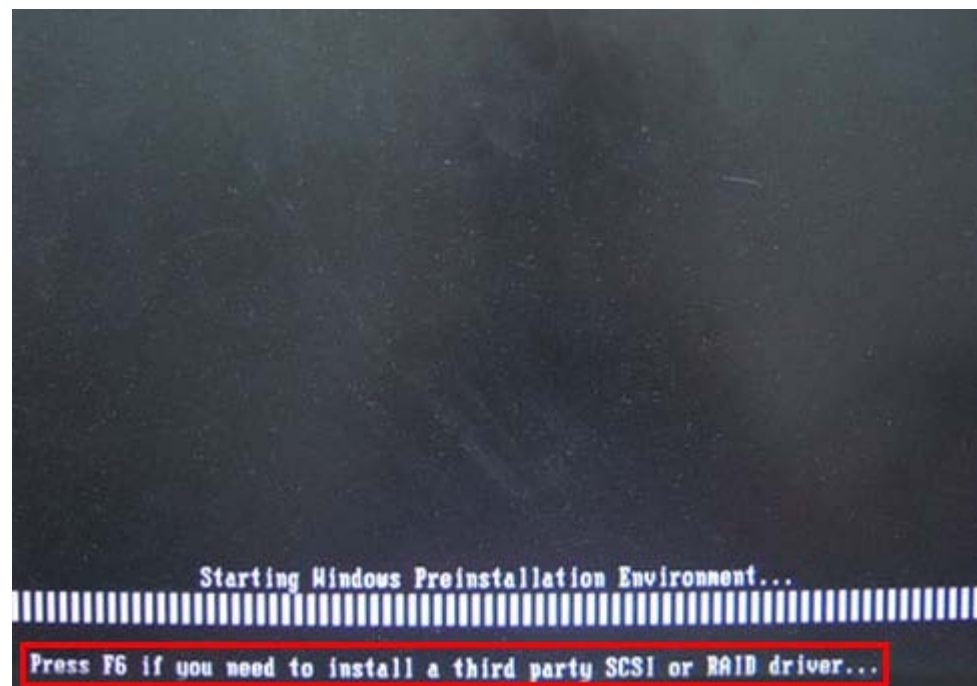

Step 5: When the following window appears, press <S> to select “Specify Additional Device”.

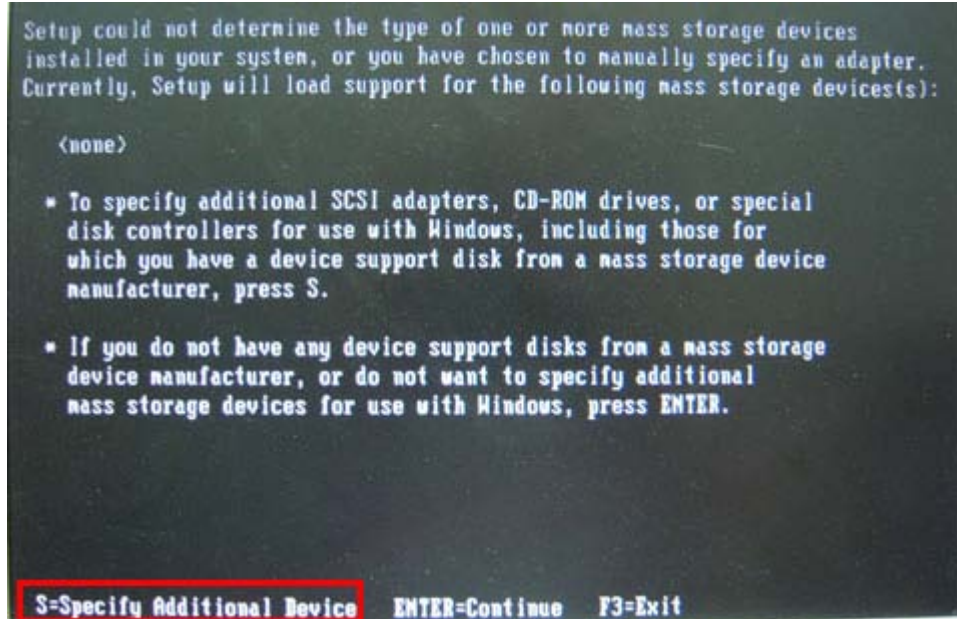

Step 6: In the following window, select a SATA controller mode used in the system. Then press <Enter>. The user can now start using the SATA HDD.

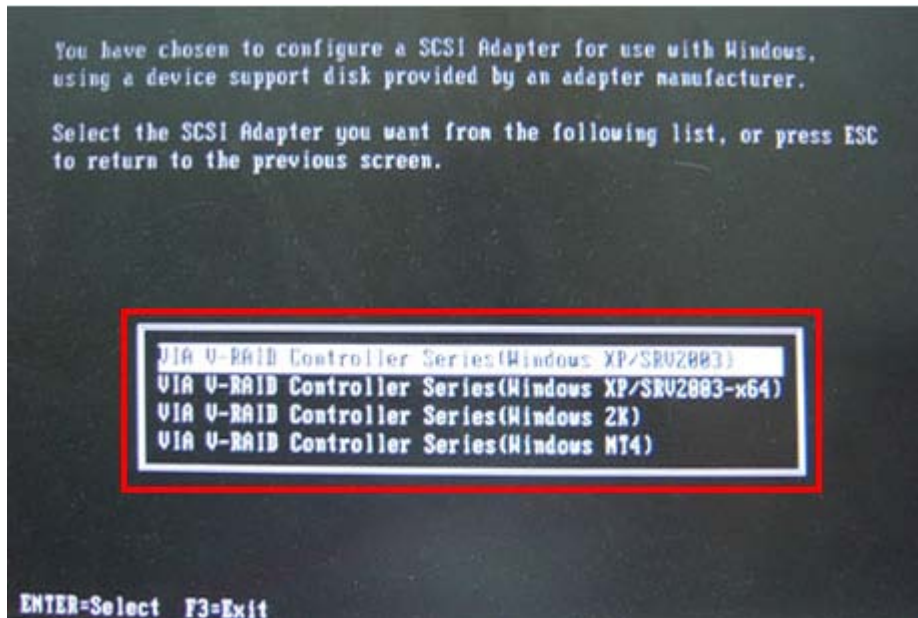

KINO-AQ870

Step 7: After pressing <Enter>, the system will get into the recovery tool setup menu.

Continue to follow the setup procedure from **Step 4** in **Section B.2.2 Create Partitions** to finish the whole setup process.

B.7.2 System Memory Requirement

To be able to access the recovery tool by pressing <F3> while booting up the system, please make sure to have enough system memory. The minimum memory requirement is listed below.

- **Using Award BIOS:** 128 MB system memory
- **Using AMI BIOS:** 512 MB system memory.

Appendix

C

Terminology

KINO-AQ870

AC '97	Audio Codec 97 (AC'97) refers to a codec standard developed by Intel® in 1997.
ACPI	Advanced Configuration and Power Interface (ACPI) is an OS-directed configuration, power management, and thermal management interface.
AHCI	Advanced Host Controller Interface (AHCI) is a SATA Host controller register-level interface.
ATA	The Advanced Technology Attachment (ATA) interface connects storage devices including hard disks and CD-ROM drives to a computer.
APM	The Advanced Power Management (APM) application program interface (API) enables the inclusion of power management in the BIOS.
ARMD	An ATAPI Removable Media Device (ARMD) is any ATAPI device that supports removable media, besides CD and DVD drives.
ASKIR	Amplitude Shift Keyed Infrared (ASKIR) is a form of modulation that represents a digital signal by varying the amplitude (“volume”) of the signal. A low amplitude signal represents a binary 0, while a high amplitude signal represents a binary 1.
BIOS	The Basic Input/Output System (BIOS) is firmware that is first run when the computer is turned on and can be configured by the end user
CODEC	The Compressor-Decompressor (CODEC) encodes and decodes digital audio data on the system.
CMOS	Complimentary metal-oxide-conductor is a type of integrated circuit used in chips like static RAM and microprocessors.
COM	COM is used to refer to serial ports. Serial ports offer serial communication to expansion devices. The serial port on a personal

	computer is usually a male DE-9 connector.
DAC	The Digital-to-Analog Converter (DAC) converts digital signals to analog signals.
DDR	Double Data Rate refers to a data bus transferring data on both the rising and falling edges of the clock signal.
DMA	Direct Memory Access (DMA) enables some peripheral devices to bypass the system processor and communicate directly with the system memory.
DIMM	Dual Inline Memory Modules are a type of RAM that offer a 64-bit data bus and have separate electrical contacts on each side of the module.
EHCI	The Enhanced Host Controller Interface (EHCI) specification is a register-level interface description for USB 2.0 Host Controllers.
GbE	Gigabit Ethernet (GbE) is an Ethernet version that transfers data at 1.0 Gbps and complies with the IEEE 802.3-2005 standard.
GPIO	General purpose input
IrDA	Infrared Data Association (IrDA) specify infrared data transmission protocols used to enable electronic devices to wirelessly communicate with each other.
L1 Cache	The Level 1 Cache (L1 Cache) is a small memory cache built into the system processor.
L2 Cache	The Level 2 Cache (L2 Cache) is an external processor memory cache.
LVDS	Low-voltage differential signaling (LVDS) is a dual-wire, high-speed differential electrical signaling system commonly used to connect LCD displays to a computer.
MAC	The Media Access Control (MAC) protocol enables several terminals or network nodes to communicate in a LAN, or other multipoint networks.

KINO-AQ870

PCIe	PCI Express (PCIe) is a communications bus that uses dual data lines for full-duplex (two-way) serial (point-to-point) communications between the SBC components and/or expansion cards and the SBC chipsets. Each line has a 2.5 Gbps data transmission rate and a 250 MBps sustained data transfer rate.
POST	The Power-on Self Test (POST) is the pre-boot actions the system performs when the system is turned-on.
QVGA	Quarter Video Graphics Array (QVGA) refers to a display with a resolution of 320 x 240 pixels.
RAM	Random Access Memory (RAM) is a form of storage used in computer. RAM is volatile memory, so it loses its data when power is lost. RAM has very fast data transfer rates compared to other storage like hard drives.
SATA	Serial ATA (SATA) is a serial communications bus designed for data transfers between storage devices and the computer chipsets. The SATA bus has transfer speeds up to 1.5 Gbps and the SATA 3Gb/s bus has data transfer speeds of up to 3.0 Gbps.
S.M.A.R.T	Self Monitoring Analysis and Reporting Technology (S.M.A.R.T) refers to automatic status checking technology implemented on hard disk drives.
UART	Universal Asynchronous Receiver-transmitter (UART) is responsible for asynchronous communications on the system and manages the system's serial communication (COM) ports.
UHCI	The Universal Host Controller Interface (UHCI) specification is a register-level interface description for USB 1.1 Host Controllers.
USB	The Universal Serial Bus (USB) is an external bus standard for interfacing devices. USB 1.1 supports 12Mbps data transfer rates, while

USB 2.0 supports 480Mbps data transfer rates.

VGA

The Video Graphics Array (VGA) is a graphics display system developed by IBM.

Appendix

D

Watchdog Timer

**NOTE:**

The following discussion applies to DOS environment. IEI support is contacted or the IEI website visited for specific drivers for more sophisticated operating systems, e.g., Windows and Linux.

The Watchdog Timer is provided to ensure that standalone systems can always recover from catastrophic conditions that cause the CPU to crash. This condition may have occurred by external EMI or a software bug. When the CPU stops working correctly, Watchdog Timer either performs a hardware reset (cold boot) or a Non-Maskable Interrupt (NMI) to bring the system back to a known state.

A BIOS function call (INT 15H) is used to control the Watchdog Timer:

INT 15H:

AH – 6FH Sub-function:	
AL – 2:	Sets the Watchdog Timer's period.
BL:	Time-out value (Its unit-second is dependent on the item "Watchdog Timer unit select" in CMOS setup).

Table D-1: AH-6FH Sub-function

Call sub-function 2 to set the time-out period of Watchdog Timer first. If the time-out value is not zero, the Watchdog Timer starts counting down. While the timer value reaches zero, the system resets. To ensure that this reset condition does not occur, calling sub-function 2 must periodically refresh the Watchdog Timer. However, the Watchdog timer is disabled if the time-out value is set to zero.

A tolerance of at least 10% must be maintained to avoid unknown routines within the operating system (DOS), such as disk I/O that can be very time-consuming.

**NOTE:**

When exiting a program it is necessary to disable the Watchdog Timer, otherwise the system resets.

Example program:

; INITIAL TIMER PERIOD COUNTER

;

W_LOOP:

```

MOV    AX, 6F02H    ;setting the time-out value
MOV    BL, 30H      ;time-out value is 48 seconds
INT    15H

```

;

; ADD THE APPLICATION PROGRAM HERE

;

```

CMP    EXIT_AP, 1    ;is the application over?
JNE    W_LOOP        ;No, restart the application

```

```

MOV    AX, 6F02H    ;disable Watchdog Timer
MOV    BL, 0        ;
INT    15H

```

;

; EXIT ;

Appendix

E

Hazardous Materials Disclosure

KINO-AQ870

E.1 Hazardous Material Disclosure Table for IPB Products Certified as RoHS Compliant Under 2002/95/EC Without Mercury

The details provided in this appendix are to ensure that the product is compliant with the Peoples Republic of China (China) RoHS standards. The table below acknowledges the presences of small quantities of certain materials in the product, and is applicable to China RoHS only.

A label will be placed on each product to indicate the estimated “Environmentally Friendly Use Period” (EFUP). This is an estimate of the number of years that these substances would “not leak out or undergo abrupt change.” This product may contain replaceable sub-assemblies/components which have a shorter EFUP such as batteries and lamps. These components will be separately marked.

Please refer to the table on the next page.

Part Name	Toxic or Hazardous Substances and Elements					
	Lead (Pb)	Mercury (Hg)	Cadmium (Cd)	Hexavalent Chromium (CR(VI))	Polybrominated Biphenyls (PBB)	Polybrominated Diphenyl Ethers (PBDE)
Housing	X	O	O	O	O	X
Display	X	O	O	O	O	X
Printed Circuit Board	X	O	O	O	O	X
Metal Fasteners	X	O	O	O	O	O
Cable Assembly	X	O	O	O	O	X
Fan Assembly	X	O	O	O	O	X
Power Supply Assemblies	X	O	O	O	O	X
Battery	O	O	O	O	O	O

O: This toxic or hazardous substance is contained in all of the homogeneous materials for the part is below the limit requirement in SJ/T11363-2006

X: This toxic or hazardous substance is contained in at least one of the homogeneous materials for this part is above the limit requirement in SJ/T11363-2006

KINO-AQ870

此附件旨在确保本产品符合中国 RoHS 标准。以下表格标示此产品中某有毒物质的含量符合中国 RoHS 标准规定的限量要求。

本产品上会附有“环境友好使用期限”的标签，此期限是估算这些物质“不会有泄漏或突变”的年限。本产品可能包含有较短的环境友好使用期限的可替换元件，像是电池或灯管，这些元件将会单独标示出来。

部件名称	有毒有害物质或元素					
	铅 (Pb)	汞 (Hg)	镉 (Cd)	六价铬 (CR(VI))	多溴联苯 (PBB)	多溴二苯醚 (PBDE)
壳体	X	O	O	O	O	X
显示	X	O	O	O	O	X
印刷电路板	X	O	O	O	O	X
金属螺帽	X	O	O	O	O	O
电缆组装	X	O	O	O	O	X
风扇组装	X	O	O	O	O	X
电力供应组装	X	O	O	O	O	X
电池	O	O	O	O	O	O

O: 表示该有毒有害物质在该部件所有物质材料中的含量均在 SJ/T11363-2006 标准规定的限量要求以下。

X: 表示该有毒有害物质至少在该部件的某一均质材料中的含量超出 SJ/T11363-2006 标准规定的限量要求。