

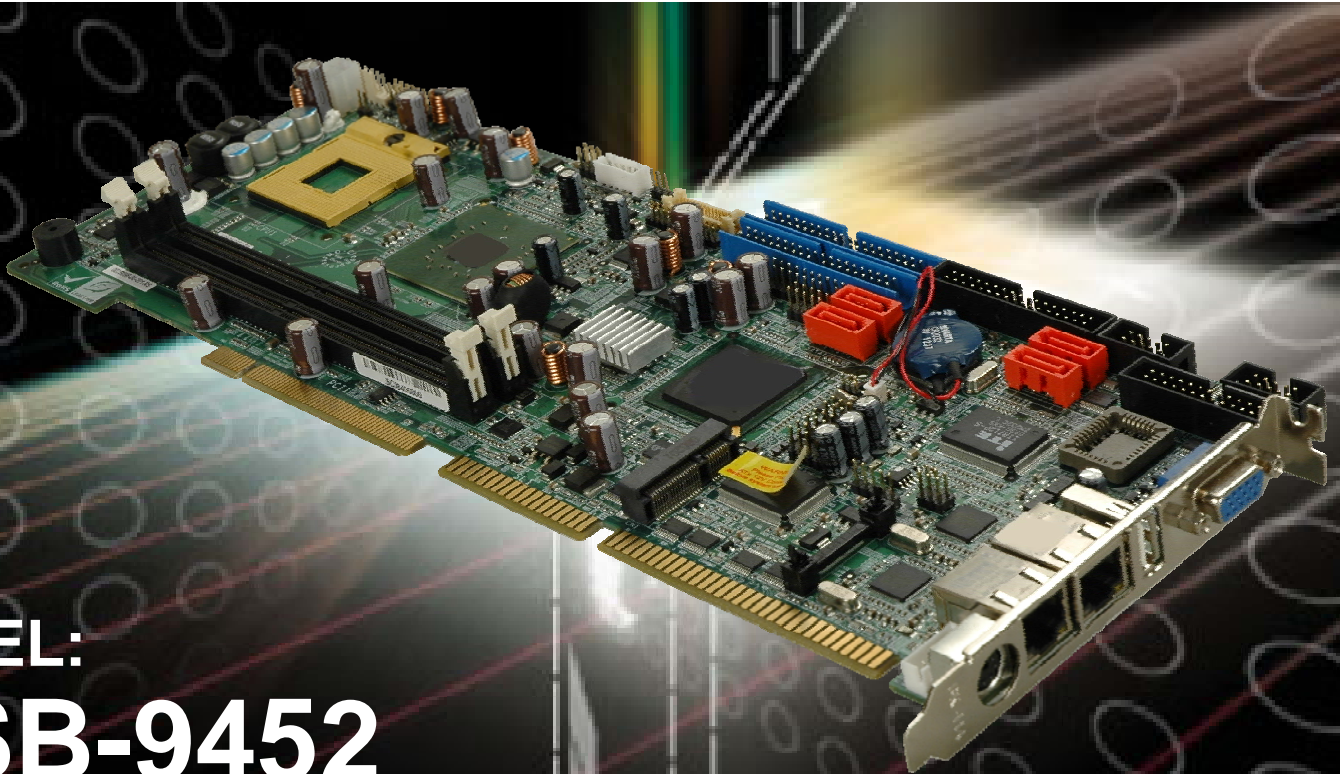

IEI Technology Corp.



**MODEL:
WSB-9452**

**Full-Size PICMG 1.0 CPU Card with Intel® Core™2 Duo/Solo,
VGA/DVI, Dual PCIe GbE, SATA 3Gb/s and Audio**

User Manual

Rev. 2.01 – 12 October, 2010



Revision

Date	Version	Changes
2010-10-12	2.01	Minor changes
2008-10-28	2.00	Changed northbridge chipset from Intel® 945GM to Intel® 945GME Added JAUTO1 and JLAN_PWR1 jumpers information
2007-09-04	1.01	Changed the Maximum memory in Table 1-1 from 2GB to 4GB Added Disclosure of Hazardous Materials Appendix (Appendix F) Added Packing List Chapter (Chapter 3)
2006-12-18	1.0	Initial release

Manual Conventions

**WARNING!**

Warnings appear where overlooked details may cause damage to the equipment or result in personal injury. Warnings should be taken seriously. Warnings are easy to recognize. The word “warning” is written as “**WARNING**,” both capitalized and bold and is followed by text. The text is the warning message. A warning message is shown below:

**WARNING:**

This is an example of a warning message. Failure to adhere to warning messages may result in permanent damage to the WSB-9452 or personal injury to the user. Please take warning messages seriously.

**CAUTION!**

Cautionary messages should also be heeded to help reduce the chance of losing data or damaging the WSB-9452. Cautions are easy to recognize. The word “caution” is written as “**CAUTION**,” both capitalized and bold and is followed. The italicized text is the cautionary message. A caution message is shown below:

**CAUTION:**

This is an example of a caution message. Failure to adhere to cautions messages may result in permanent damage to the WSB-9452. Please take caution messages seriously.

**NOTE:**

These messages inform the reader of essential but non-critical information. These messages should be read carefully as any directions or instructions contained therein can help avoid making mistakes. Notes are easy to recognize. The word “note” is written as “**NOTE**,” both capitalized and bold and is followed by text. The text is the cautionary message. A note message is shown below:

**NOTE:**

This is an example of a note message. Notes should always be read. Notes contain critical information about the WSB-9452. Please take note messages seriously.

Copyright

The information in this document is subject to change without prior notice in order to improve reliability, design and function and does not represent a commitment on the part of the manufacturer.

In no event will the manufacturer be liable for direct, indirect, special, incidental, or consequential damages arising out of the use or inability to use the product or documentation, even if advised of the possibility of such damages.

This document contains proprietary information protected by copyright. All rights are reserved. No part of this manual may be reproduced by any mechanical, electronic, or other means in any form without prior written permission of the manufacturer.

TRADEMARKS

All registered trademarks and product names mentioned herein are used for identification purposes only and may be trademarks and/or registered trademarks of their respective owners.

Table of Contents

1	INTRODUCTION.....	1
1.1	WSB-9452 CPU CARD OVERVIEW	2
1.1.1	<i>WSB-9452 Model Variations.....</i>	2
1.1.2	<i>WSB-9452 CPU Card Applications.....</i>	2
1.1.3	<i>WSB-9452 CPU Card Benefits.....</i>	2
1.1.4	<i>WSB-9452 CPU Card Features</i>	3
1.2	WSB-9452 CPU CARD OVERVIEW	4
1.2.1	<i>WSB-9452 CPU Card Connectors.....</i>	5
1.2.2	<i>Technical Specifications.....</i>	6
2	DETAILED SPECIFICATIONS	9
2.1	COMPATIBLE IEI BACKPLANES.....	10
2.2	CPU SUPPORT	10
2.2.1	<i>Intel® Core™2 Duo.....</i>	10
2.2.2	<i>Intel® Core™ Duo.....</i>	11
2.2.3	<i>Intel® Core™ Solo</i>	11
2.2.4	<i>Intel® Celeron® M</i>	12
2.3	ON-BOARD CHIPSETS	12
2.3.1	<i>Northbridge and Southbridge Chipsets</i>	12
2.3.2	<i>Intel® 945GME Northbridge Chipset.....</i>	12
2.3.3	<i>Intel ICH7-M Southbridge Chipset.....</i>	13
2.4	GRAPHICS SUPPORT.....	14
2.4.1	<i>Intel® GMA 950.....</i>	14
2.4.2	<i>Analog VGA</i>	15
2.4.3	<i>Digital LVDS.....</i>	15
2.4.4	<i>Digital Visual Interface (DVI).....</i>	15
2.5	DATA FLOW	16
2.6	MEMORY SUPPORT	17
2.7	PCI BUS INTERFACE SUPPORT	17
2.8	GBE ETHERNET CONNECTION	18
2.9	DRIVE INTERFACES	18

WSB-9452 PICMG 1.0 CPU Card

2.9.1	SATA Drives	19
2.9.2	IDE HDD Interfaces	19
2.9.3	Floppy Disk Drive (FDD).....	19
2.10	SATA II AND RAID FUNCTIONALITY (SATA3 AND SATA4 ONLY).....	20
2.11	SERIAL PORTS.....	20
2.12	REAL TIME CLOCK.....	20
2.13	SYSTEM MONITORING.....	21
2.14	INFRARED DATA ASSOCIATION (IRDA) INTERFACE	21
2.15	USB INTERFACES	21
2.16	BIOS.....	21
2.17	OPERATING TEMPERATURE AND TEMPERATURE CONTROL.....	22
2.18	OPTIONAL AUDIO INTERFACE.....	22
2.19	POWER CONSUMPTION.....	22
2.20	PACKAGED CONTENTS AND OPTIONAL ACCESSORY ITEMS.....	23
2.20.1	Package Contents.....	23
2.20.2	Special Items	23
2.20.3	Optional Accessory Items.....	24
3	UNPACKING	25
3.1	ANTI-STATIC PRECAUTIONS	26
3.2	UNPACKING.....	26
3.2.1	Unpacking Precautions.....	26
3.3	UNPACKING CHECKLIST	27
3.3.1	Package Contents.....	27
3.4	OPTIONAL ITEMS	29
4	CONNECTORS AND JUMPERS	30
4.1	PERIPHERAL INTERFACE CONNECTORS.....	31
4.1.1	WSB-9452 CPU card Layout	31
4.1.2	Peripheral Interface Connectors	32
4.1.3	External Peripheral Interface Connectors.....	33
4.1.4	On-board Jumpers	34
4.2	INTERNAL PERIPHERAL CONNECTORS	34
4.2.1	ATX-12V Power Source Connector.....	34
4.2.2	Audio Module Connector.....	36

4.2.3 Backplane to Mainboard Power Connector	37
4.2.4 Battery Connector.....	39
4.2.5 CPU Fan Connector	40
4.2.6 Digital Input/Output (DIO) Connector.....	42
4.2.7 DVI (Digital Visual Interface) Connector.....	43
4.2.8 FDD Connector	45
4.2.9 Front Panel Connector	47
4.2.10 IDE Connectors	49
4.2.11 Inverter Connector.....	50
4.2.12 IrDA Interface Connector.....	52
4.2.13 Keyboard Connector.....	53
4.2.14 LVDS Connector	55
4.2.15 Parallel Port Connector	56
4.2.16 PCI Express Mini Card Connector.....	58
4.2.17 RS-232 Serial Port Connectors.....	61
4.2.18 SATA Drive Connectors	63
4.2.19 Trusted Platform Module Connector	65
4.2.20 TV Out Connector	67
4.2.21 USB Connectors.....	69
4.3 EXTERNAL PERIPHERAL INTERFACECONNECTORS	70
4.3.1 LAN Connectors.....	71
4.3.2 Mini-DIN 6 PS/2 Connector	72
4.3.3 USB Connector	73
4.3.4 VGA connector.....	74
5 INSTALLATION AND CONFIGURATION	76
5.1 ANTI-STATIC PRECAUTIONS	77
5.2 INSTALLATION CONSIDERATIONS.....	77
5.2.1 Installation Notices	77
5.3 UNPACKING.....	78
5.3.1 Unpacking Precautions.....	78
5.3.2 Checklist.....	79
5.4 WSB-9452 CPU CARD INSTALLATION.....	80
5.4.1 Socket 478 CPU Installation.....	81
5.4.2 Cooling Kit (CF-479B-RS) Installation.....	83

WSB-9452 PICMG 1.0 CPU Card

5.4.3	<i>DIMM Module Installation</i>	86
5.4.3.1	<i>Purchasing the Memory Module</i>	86
5.4.3.2	<i>DIMM Module Installation</i>	87
5.4.4	<i>Peripheral Device Connection</i>	89
5.4.4.1	<i>IDE Disk Drive Connectors (IDE1, IDE2)</i>	90
5.4.4.2	<i>Floppy Drive Connector (FDD1)</i>	92
5.4.5	<i>SATA Drive Connection</i>	92
5.4.6	<i>Installing the RS-232 Cable</i>	94
5.4.7	<i>USB 2.0 Cable Connection</i>	95
5.5	ON-BOARD JUMPERS	97
5.5.1	<i>AT Power Select Jumper Settings</i>	97
5.5.2	<i>Clear CMOS Jumper</i>	98
5.5.3	<i>LVDS LCD Voltage Selection</i>	100
5.5.4	<i>LAN Power Selection</i>	102
5.6	CHASSIS INSTALLATION	104
5.7	REAR PANEL CONNECTORS	104
5.7.1	<i>Keyboard and Mouse Connection</i>	104
5.7.2	<i>VGA Port Installation</i>	104
5.7.3	<i>Ethernet Connection</i>	104
5.7.4	<i>USB Connection</i>	104
6	AMI BIOS SETUP	105
6.1	INTRODUCTION	106
6.1.1	<i>Starting Setup</i>	106
6.1.2	<i>Using Setup</i>	106
6.1.3	<i>Getting Help</i>	107
6.1.4	<i>Unable to Reboot after Configuration Changes</i>	107
6.1.5	<i>BIOS Menu Bar</i>	107
6.2	MAIN	108
6.3	ADVANCED	109
6.3.1	<i>CPU Configuration</i>	111
6.3.2	<i>IDE Configuration</i>	112
6.3.2.1	<i>IDE Master, IDE Slave</i>	115
6.3.3	<i>Floppy Configuration</i>	119
6.3.4	<i>Super IO Configuration</i>	120

6.3.5	Hardware Health Configuration.....	124
6.3.6	ACPI Configuration.....	127
6.3.6.1	General ACPI Configuration.....	128
6.3.7	APM Configuration.....	130
6.3.8	MPS Configuration.....	133
6.3.9	Remote Access Configuration.....	134
6.3.10	Trusted Computing.....	139
6.3.11	USB Configuration.....	140
6.4	PCI/PNP.....	143
6.5	BOOT.....	151
6.5.1	Boot Settings Configuration.....	151
6.5.2	Boot Device Priority.....	155
6.5.3	Hard Disk Drives.....	156
6.5.4	Removable Drives.....	157
6.6	SECURITY.....	159
6.7	CHIPSET.....	161
6.7.1	Northbridge Configuration.....	162
6.7.1.1	Video Function Configuration.....	165
6.7.2	Southbridge Configuration.....	170
6.8	EXIT.....	173
7	SOFTWARE DRIVERS.....	175
7.1	AVAILABLE SOFTWARE DRIVERS.....	176
7.2	CHIPSET DRIVER INSTALLATION.....	176
7.3	VGA DRIVER.....	181
7.4	BROADCOM LAN DRIVER (FOR GBE LAN) INSTALLATION.....	186
7.5	REALTEK HD AUDIO DRIVER (ALC883) INSTALLATION.....	192
7.5.1	BIOS Setup.....	192
7.5.2	Driver Installation.....	192
7.6	REALTEK AC'97 AUDIO DRIVER (ALC665) INSTALLATION.....	197
7.6.1	BIOS Setup.....	197
7.6.2	Driver Installation.....	197
A	BIOS CONFIGURATION OPTIONS.....	205
A.1	BIOS CONFIGURATION OPTIONS.....	206

B	WATCHDOG TIMER	210
C	EXTERNAL AC'97 AUDIO CODEC	213
	C.1 INTRODUCTION	214
	C.2 PHYSICAL CONNECTION	216
	C.3 DRIVER INSTALLATION	216
	C.4 SOUND EFFECT CONFIGURATION	218
	C.5 SOUND EFFECT	219
	C.6 ENVIRONMENT SIMULATION	219
	C.7 KARAOKE MODE	221
	C.8 EQUALIZER SELECTION	222
	C.9 SPEAKER CONFIGURATION.....	223
	C.10 SPEAKER TEST.....	224
	C.11 S/PDIF-IN & S/PDIF-OUT	225
	C.12 CONNECTOR SENSING.....	226
	C.13 HRTF DEMO	229
	C.14 MICROPHONE EFFECT	229
	C.15 GENERAL.....	230
D	JMICRON RAID SETUP	231
	D.1 INTRODUCTION.....	232
	<i>D.1.1 RAID Support.....</i>	232
	<i>D.1.2 What is RAID.....</i>	232
	D.2 RAID SETUP	233
	<i>D.2.1 Introduction.....</i>	233
	<i>D.2.2 Install SATA Drives</i>	233
	<i>D.2.3 Configure the SATA Controller in BIOS.....</i>	233
	<i>D.2.4 Configure the RAID BIOS.....</i>	234
	D.2.4.1 Create a RAID volume.....	235
	D.2.4.2 Delete a RAID volume.....	239
	D.2.4.3 Revert an HDD to Non-RAID	241
	D.2.4.4 Solve Mirror Conflict.....	243
	D.2.4.5 Rebuild Mirror Drive	244
	D.2.4.6 Save and Exit Setup	245
	D.2.4.7 Exit without Saving.....	245

<i>D.2.5 Install the OS</i>	246
E HAZARDOUS MATERIALS DISCLOSURE	247
E.1 HAZARDOUS MATERIAL DISCLOSURE TABLE FOR IPB PRODUCTS CERTIFIED AS ROHS COMPLIANT UNDER 2002/95/EC WITHOUT MERCURY	248
F INDEX	251

List of Figures

Figure 1-1: Data Flow Block Diagram.....	4
Figure 2-1: Data Flow Block Diagram.....	16
Figure 4-1: ATX–12V Connector Location	35
Figure 4-2: Audio Connector Location.....	36
Figure 4-3: Backplane to Mainboard Power Connector Location	38
Figure 4-4: Battery Connector Location	39
Figure 4-5: CPU Fan Connector Location.....	41
Figure 4-6: DIO Connector Location	42
Figure 4-7: DVI Connector Location.....	44
Figure 4-8: FDD Connector Location	46
Figure 4-9: Front Panel Connector Location	48
Figure 4-10: IDE Connectors Location.....	49
Figure 4-11: Inverter Connector Location.....	51
Figure 4-12: IrDA Interface Connector Location	52
Figure 4-13: Keyboard Connector Location	54
Figure 4-14: LVDS Connector Location	55
Figure 4-15: Parallel Port Connector Location.....	57
Figure 4-16: PCI Express Mini Card Connector Location	60
Figure 4-17: RS-232 Serial Port Connector Location	62
Figure 4-18: SATA Connectors Location	64
Figure 4-19: TPM Connector Location	66
Figure 4-20: TV Out Connector Location	68
Figure 4-21: USB Port Connector Location	69
Figure 4-22: External Peripheral Interface Connector Panel	70
Figure 4-23: RJ-45 Ethernet Connector	72
Figure 4-24: Mini-DIN 6 PS/2 Connector	73
Figure 4-25: VGA Connector	74
Figure 5-1: Make sure the CPU socket retention screw is unlocked	82

Figure 5-2: Lock the CPU Socket Retention Screw	83
Figure 5-3: IEI CF-479B-RS Cooling Kit	83
Figure 5-4: Install Support Bracket	84
Figure 5-5: Align the Cooling Kit	85
Figure 5-6: Secure the Cooling Kit	86
Figure 5-7: Installing the DIMM Module	88
Figure 5-8: Connection of IDE Connector.....	91
Figure 5-9: SATA Drive Cable Connection	93
Figure 5-10: SATA Drive Connection	94
Figure 5-11: Dual RS-232 Cable Installation	95
Figure 5-12: USB Cable Installation	96
Figure 5-13 Jumper	97
Figure 5-14: AT Power Select Jumper Location.....	98
Figure 5-15: Clear CMOS Jumper	100
Figure 5-16: LVDS Voltage Selection Jumper Pinout Locations.....	102
Figure 5-17: LAN Power Selection Jumper Location	103
Figure 7-1: InstallShield Wizard Preparation Screen.....	177
Figure 7-2: Welcome Screen	177
Figure 7-3: License Agreement.....	178
Figure 7-4: Readme Information	179
Figure 7-5: Restart the Computer	180
Figure 7-6: Starting Install Shield Wizard Screen	181
Figure 7-7: Preparing Setup Screen	182
Figure 7-8: VGA Driver Installation Welcome Screen.....	183
Figure 7-9: VGA Driver License Agreement	184
Figure 7-10: VGA Driver Installing Notice.....	184
Figure 7-11: VGA Driver Installation Complete	185
Figure 7-12: Access Windows Control Panel.....	186
Figure 7-13: Double Click the System Icon	187
Figure 7-14: Double Click the Device Manager Tab.....	188
Figure 7-15: Device Manager List	188
Figure 7-16: Search for Suitable Driver.....	189

Figure 7-17: Locate Driver Files.....	190
Figure 7-18: Location Browsing Window.....	191
Figure 7-19: 4-AUDIO\AC-KIT883HD\Windows Folder.....	193
Figure 7-20: HD Audio Driver Setup Extracting Files	194
Figure 7-21: HD Audio Driver Setup Welcome Screen	195
Figure 7-22: HD Audio Driver Installation Complete	196
Figure 7-23: CD 4-AUDIO\AC-KIT08R\Windows Folder	198
Figure 7-24: AC`97 Audio Driver Install Shield Wizard Starting.....	198
Figure 7-25: AC`97 Audio Driver Setup Preparation.....	199
Figure 7-26: AC`97 Audio Driver Welcome Screen.....	200
Figure 7-27: AC`97 Audio Driver Software Configuration.....	201
Figure 7-28: AC`97 Audio Driver Digital Signal	202
Figure 7-29: AC`97 Audio Driver Installation Begins.....	203
Figure 7-30: AC`97 Audio Driver Installation Complete	204

List of Tables

Table 1-1: WSB-9452 Model Variations	2
Table 1-2: Technical Specifications	8
Table 2-1: Supported CPUs	10
Table 2-2: Power Consumption.....	22
Table 3-1: Package List Contents	28
Table 3-2: Package List Contents	29
Table 4-1: Connector and Jumper Locations	31
Table 4-2: Peripheral Interface Connectors.....	33
Table 4-3: External Peripheral Interface Connectors	33
Table 4-4: On-board Jumpers	34
Table 4-5: ATX-12V Connector Pinouts.....	35
Table 4-6: Audio Connector Pinouts	37
Table 4-7: Backplane to Mainboard Power Pin Outs	38
Table 4-8: Battery Connector Pinouts.....	40
Table 4-9: CPU Fan Connector Pinouts	41
Table 4-10: DIOConnector Pinouts.....	43
Table 4-11: DVI Connector Pinouts	45
Table 4-12: FDD Connector Pinouts.....	47
Table 4-13: Front Panel Connector Location.....	48
Table 4-14: IDE Connector Pinouts	50
Table 4-15: Inverter Connector Pinouts	51
Table 4-16: IrDA Interface Connector Pinouts.....	53
Table 4-17: KB1 Connector Pinouts	54
Table 4-18: LVDS Connector Pinouts.....	56
Table 4-19: Parallel Port Connector Pinouts	58
Table 4-20: PCI Express Mini Card Connector Pinouts.....	61
Table 4-21: RS-232 Serial Port Connector Pinouts.....	63
Table 4-22: SATA Connectors Pinouts	64

WSB-9452 PICMG 1.0 CPU Card

Table 4-23: TPM Connector Pinouts.....	67
Table 4-24: TV Out Connector Pinouts	68
Table 4-25: USB Port Connector Pinouts	70
Table 4-26: LAN Pinouts	71
Table 4-27: Ethernet Connector Pinouts.....	71
Table 4-28: Mini-DIN 6 PS/2 Connector	73
Table 4-29: USB Port Pinouts.....	74
Table 4-30: VGA Connector Pinouts	75
Table 5-1: IEI Provided Cables	89
Table 5-2: On-board Jumpers	97
Table 5-3: AT Power Select Jumper Settings.....	98
Table 5-4: Clear CMOS Jumper Settings	99
Table 5-5: LVDS LCD Voltage Selection Jumper Settings.....	101
Table 5-6: LCD Voltage Selection Jumper Settings.....	103
Table 6-1: BIOS Navigation Keys.....	107

List of BIOS Menus

BIOS Menu 1: Main.....	108
BIOS Menu 2: Advanced.....	110
BIOS Menu 3: CPU Configuration.....	111
BIOS Menu 4: IDE Configuration	113
BIOS Menu 5: IDE Master and IDE Slave Configuration.....	115
BIOS Menu 6: Floppy Configuration	119
BIOS Menu 7: Super IO Configuration	120
BIOS Menu 8: Hardware Health Configuration.....	124
BIOS Menu 9: ACPI Configuration.....	127
BIOS Menu 10: General ACPI Configuration	128
BIOS Menu 11: APM Configuration	130
BIOS Menu 12: MPS Configuration	133
BIOS Menu 13: Remote Access Configuration	134
BIOS Menu 14: Trusted Computing Configuration.....	139
BIOS Menu 15: USB Configuration.....	140
BIOS Menu 16: PCI/PnP Configuration	145
BIOS Menu 17: Boot.....	151
BIOS Menu 18: Boot Settings Configuration.....	152
BIOS Menu 19: Boot Device Priority Settings	155
BIOS Menu 20: Hard Disk Drives	156
BIOS Menu 21: Removable Drives.....	158
BIOS Menu 22: Security.....	159
BIOS Menu 23: Chipset.....	161
BIOS Menu 24: Northbridge Chipset Configuration	162
BIOS Menu 25: Video Function Configuration	165
BIOS Menu 26:Southbridge Chipset Configuration.....	170
BIOS Menu 27:Exit	173

Chapter

1

Introduction

1.1 WSB-9452 CPU Card Overview

The PICMG 1.0 form factor WSB-9452 CPU card with Intel® Core™ 2 Duo/ Intel® Core™ Duo/ Intel® Core™ Solo / Intel® Celeron® M processor platform is fully equipped with the latest technology and advanced multi-mode I/Os. The WSB-9452 is designed for system manufacturers, integrators, and VARs that want performance, reliability, and quality at a reasonable price.

1.1.1 WSB-9452 Model Variations

The WSB-9452 has four model variations shown in **Table 1-1**.

Model Name	SATA	SATA II	IDE	Digital Video Interface (DVI)
WSB-9452-R20	Two	--	One	None
WSB-9452S-R20	Two	Two	Two	None
WSB-9452DVI-R20	Two	--	One	One
WSB-9452SDVI-R20	Two	Two	Two	One

Table 1-1: WSB-9452 Model Variations

1.1.2 WSB-9452 CPU Card Applications

The WSB-9452 CPU card has been designed for use in industrial applications where board expansion is critical and operational reliability is essential.

1.1.3 WSB-9452 CPU Card Benefits

Some of the WSB-9452 CPU card benefits include:

- Dual-core Intel® processor support
 - Two physical cores in a package share the system load
 - Each core has its own L1 cache and shares the L2 cache to enhance the processing speed
 - High performance levels especially in 3D graphic and multi media application

WSB-9452 PICMG 1.0 CPU Card

- PCI Express® Mini Card support
 - Small form factor (half the size of a mini-PCI card) allows easy integration and addresses system manufacturers' needs for build-to-order (BTO) and configure-to-order (CTO) applications
- providing access to multiple PCI and ISA expansion slots for easy system expansion
- operating reliably in harsh industrial environments with ambient temperatures as high as 60°C
- rebooting automatically if the BIOS watchdog timer detects that the system is no longer operating

1.1.4 WSB-9452 CPU Card Features

Some of the WSB-9452 CPU card features are listed below:

- PICMG 1.0 compliant
- RoHS compliant
- Intel® Core™ 2 Duo/ Intel® Core™ Duo/ Intel® Core™ Solo / Intel® Celeron® M CPUs supported
- PCI Express® Mini Card supported
- Maximum front side bus (FSB) speed of 667MHz supported
- Up to 4GB of 400/533/667MHz dual channel DDR2 memory supported
- Analog display supported
- One dual channel 24-bit LVDS port
- One DVI interface with resolution from VGA to UXGA supported by two models (see **Table 1-1**)
- Two high performance PCI Express Gigabit Ethernet (PCI-E GbE) controllers supported
- SATA II channels with transfer rates up to 300 MB/s are supported (see **Table 1-1**)
- Supports up to seven USB 2.0 devices
- RAID 0 and RAID 1 functionalities (SATA3 and SATA4 only) supported (see **Table 1-1**)

1.2 WSB-9452 CPU Card Overview

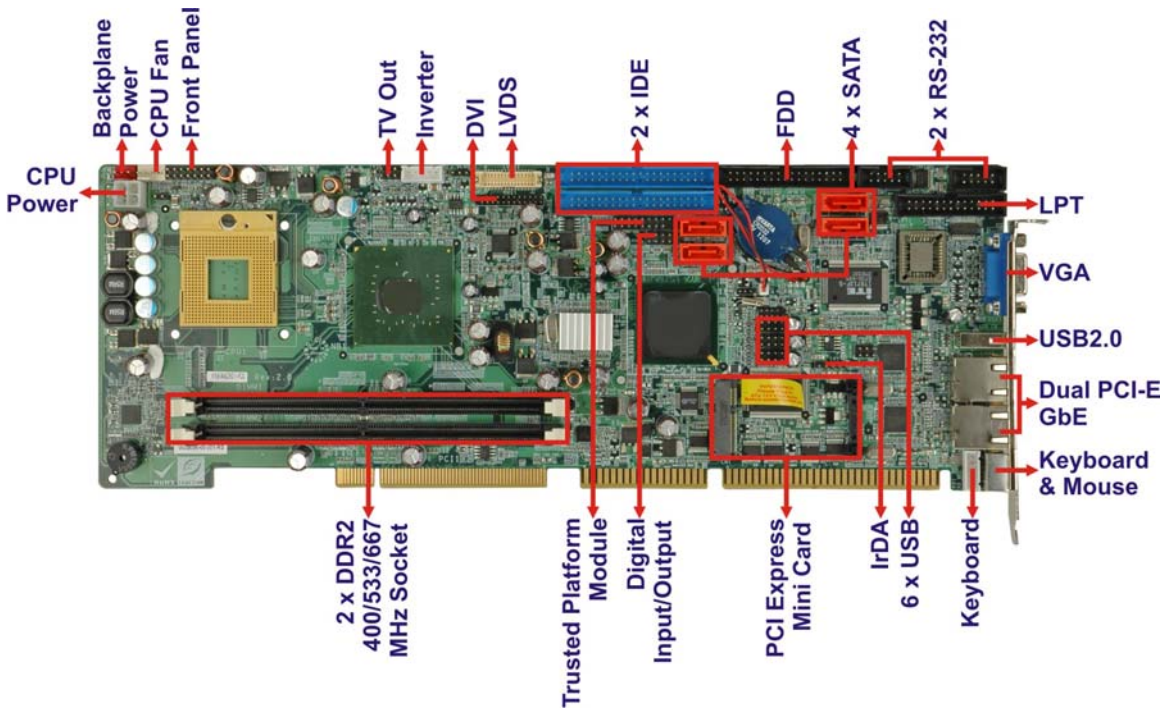

* See Table 1-1 for supported models.

Figure 1-1: Data Flow Block Diagram

1.2.1 WSB-9452 CPU Card Connectors

The WSB-9452 CPU card has the following connectors on-board:

- 1 x ATX-12V connector
- 1 x Audio module connector
- 1 x Backplane to mainboard power connector
- 1 x Battery connector
- 1 x CPU fan connector
- 1 x Digital I/O connector
- 1 x Digital Visual Interface (DVI) Connector (see **Table 1-1**)
- 1 x FDD connector
- 1 x Front panel connector
- 2 x 40-pin IDE connectors (see **Table 1-1**)
- 1 x Inverter connector
- 1 x IrDA connector
- 1 x Keyboard connector
- 1 x LVDS connector
- 1 x Parallel port connector
- 1 x PCI Express® Mini Card connector
- 2 x RS-232 Serial port connectors
- 4 x SATA connectors (see **Table 1-1**)
- 1 x TPM connector
- 1 x TV out connector
- 6 x USB connectors

The location of these connectors on the CPU card can be seen in **Figure 1-1**. These connectors are fully described in **Chapter 4**.

1.2.2 Technical Specifications

WSB-9452 CPU card technical specifications are listed in **Table 1-2**. Detailed descriptions of each specification can be found in **Chapter 2**.

SPECIFICATION	DESCRIPTION
Supported CPUs	Intel® Core™ 2 Duo Intel® Core™ Duo Intel® Core™ Solo Intel® Celeron® M
Socket	Socket M Micro-FCPGA
Chipsets	Northbridge: Intel® 945GME Southbridge: Intel® ICH7-M
Graphics Support	Intel® Graphics Media Accelerator 950 (GMA 950) <ul style="list-style-type: none"> ○ One VGA ○ One DVI (See Table 1-1) ○ One LVDS
Memory	Two 400/533/667 MHz DDR2 memory modules (Max. 4GB)
PCI Bus Interface	33MHz, Revision 2.3
ISA Bus Interface	Supports three fully compatible ISA slots without buffering ISA DMA and ISA Bus Master function are not supported
Serial ATA (SATA)	Two SATA channels or Two SATA channels and two SATA II channels

WSB-9452 PICMG 1.0 CPU Card

SPECIFICATION	DESCRIPTION
HDD Interface	One IDE channel supports two Ultra ATA 100/66/33 devices (see Table 1-1) Two IDE channels support four Ultra ATA 100/66/33 devices (see Table 1-1)
Floppy Disk Drive (FDD)	Supports FDD
USB Interfaces	Six internal USB 2.0 connectors and one external USB port support seven USB devices
Serial Ports	Two RS-232 serial port connectors (COM1 and COM2)
Real Time Clock	256-byte battery backed CMOS RAM
Hardware Monitoring	Cooling fans, temperature and system voltages
Power Management	Supports Advanced Configuration and Power Interface (ACPI) Specifications Revision 2.0
Power Consumption	5V @ 4.15A, +12V @ 1.29A (Intel® Core™ Duo 2GHz with two 1GB DDR2 667MHz)
Infrared Support	One Infrared Data Association (IrDA) interface
Ethernet	Two PCI Express Gigabit Ethernet (PCI-E GbE) channels
BIOS	AMI BIOS
Physical Dimensions	12.2cm x 34.1cm (width x length)
Operating Temperature	Minimum: 0°C (32°F) Maximum: 60°C (140°F)

SPECIFICATION	DESCRIPTION
Operating Humidity	Minimum: 5% Maximum: 95%
Optional Audio Interface	Realtek ALC655/883 with AC `97 / HD Audio

Table 1-2: Technical Specifications

Chapter

2

Detailed Specifications

2.1 Compatible IEI Backplanes

The WSB-9452 CPU card is compatible with the all IEI PICMG1.0 backplanes. For more information on these backplanes, visit the IEI website or contact your CPU card reseller or vendor.

2.2 CPU Support

Model	Capacity	Interface	FSB
Intel® Core™2 Duo T7600	2.33GHz	478	667MHz
Intel® Core™ Duo T2700	2.33GHz	478	533/667MHz
Intel® Core™ Solo T1400	1.83GHz	478	533/667MHz
Intel® Celeron® M 450	2.0GHz	478	533 MHz

Table 2-1: Supported CPUs

2.2.1 Intel® Core™2 Duo

The Intel® Core™2 Duo processor comes with the following features:

- Dual core processor with enhanced performance
- Intel® 64 architecture
- Supports Intel® Architecture with Dynamic Execution
- On-die, primary 32kB instruction cache and 32kB write-back data cache per core
- On-die, up to 4MB second level shared cache with Advanced Transfer Cache Architecture
- Data Prefetch Logic
- 667MHz, Source-Synchronous FSB for Standard Voltage processors
- Advanced Power Management features including Enhanced Intel SpeedStep® Technology
- Intel® Enhanced Deeper Sleep state and Dynamic Cache Sizing

2.2.2 Intel® Core™ Duo

The Intel® Core™ Duo processor comes with the following features:

- Two complete execution cores in one processor package provide advancements in simultaneous computing
- Dual-core processing efficiently delivers performance while balancing power requirements
- Two execution cores share a high-performance, power-optimized 667 MHz front-side bus (FSB) to access the same chipset memory.
- Enhanced Intel SpeedStep® technology allows a system to dynamically adjust processor voltage and core frequency, decreasing average power consumption and average heat production
- Intel® Smart Cache Design allows two execution cores to share 2 MB of L2 cache, reducing FSB traffic and enhancing system responsiveness
- Intel® Advanced Thermal Manager supports new digital temperature sensors and thermal monitors on each execution core to enhance thermal monitoring accuracy
- Streaming SIMD Extensions 3 (SSE3) provides significant performance enhancement for multi-media applications
- Embedded lifecycle support protects system investment by enabling extended product availability for embedded and communications customers

2.2.3 Intel® Core™ Solo

The Intel® Core™ Solo processor comes with the following features:

- Supports Intel Architecture with Dynamic Execution
- On-die, primary 32-KB instruction cache and 32-KB write-back data cache
- On-die, 2-MB second level cache with Advanced Transfer Cache Architecture
- Streaming SIMD Extensions 2 (SSE2) and Streaming SIMD Extensions 3 (SSE3)
- Advanced power management features including Enhanced Intel SpeedStep® technology

- Execute Disable Bit support for enhanced security
- Intel® Virtualization Technology enhances virtualization robustness and performance

2.2.4 Intel® Celeron® M

The Intel® Celeron® M CPU comes with the following features:

- Processor low-power states C1, C2 and C3 (Deep Sleep) lowers CPU power consumption/dissipation to conserve battery life
- Micro FCPGA packaging technology optimized for a range of thinner, lighter designs, including <1" thick
- Support for Intel® Mobile Voltage Positioning (Intel® MVP IV) dynamically lowers voltage based on processor activity to lower thermal design power, enabling smaller notebooks
- Lower core voltage – 1.356 V low-voltage operation and 24.5W thermal design power lower thermal dissipation enabling thinner notebooks
- Intel® Streaming SIMD Extensions accelerates 3D graphics performance
- Execute Disable Bit Technology prevents certain classes of malicious "buffer overflow" attacks when combined with a supporting operating system.

2.3 On-board Chipsets

2.3.1 Northbridge and Southbridge Chipsets

The following chipsets are preinstalled on the board:

- **Northbridge:** Intel® 945GME
- **Southbridge:** Intel® ICH7-M

The following two sections (**Section 2.3.2** and **Section 2.3.3**) lists some of the features of the Intel® 945GME and the Intel® ICH7-M chipsets. For more information on these two chipsets refer to the Intel website.

2.3.2 Intel® 945GME Northbridge Chipset

The Intel® 945GME Northbridge chipset comes with the following features:

WSB-9452 PICMG 1.0 CPU Card

- System Memory Support
 - Supports single/dual-channel DDR2 SDRAM
 - 64-bit wide per channel
 - 256MB, 512MB, 1GB and 2GB memory technologies supported
 - Support for DDR2 On-Die Termination (ODT)
 - Support for 2N timings only
- Internal Graphics
 - Intel® Gen 3.5 Integrated Graphics Engine
 - 250 MHz core render clock and 200 MHz core display clock at 1.05 V core voltage
 - Supports TV-Out, LVDS, CRT and SDVO
- DMI
 - Chip-to-chip interface between (G)MCH and ICH
 - Configurable as x2 or x4 DMI lanes
 - DMI lane reversal support
 - 32-bit downstream address
- Power Management
 - ACPI S0, S3, S4, S5
 - CPU States C0, C1, C2, C3, C4 states
 - Rapid Memory Power Management

2.3.3 Intel ICH7-M Southbridge Chipset

The Intel® ICH7-M Southbridge chipset comes with the following features:

- PCI Local Bus Specification, Revision 2.3 support for 33MHz PCI operations (supports up to six Req/Gnt pairs)
- ACPI Power Management Logic support
- Enhanced DMA controller, interrupt controller, and timer functions
- Integrated Serial ATA host controller with independent DMA operation on two ports and AHCI
- Integrated IDE controller supports Ultra ATA 100/66/33
- USB host interface with support for eight USB ports; four UHCI host controller; one EHCI high-speed USB 2.0 Host controller
- Supports Audio Codec '97, Revision 2.3 Specification
- Supports Intel® High Definition Audio

- Supports Intel® Matrix Storage Technology
- Supports Intel® Active Management Technology
- Low Pin Count (LPC) interface
- Firmware Hub (FWH) interface support
- Serial Peripheral Interface (SPI) support

2.4 Graphics Support

2.4.1 Intel® GMA 950

The Intel® GMA 950 integrated on the Intel® 945GME chipset has the following features.

- Intel® GMA 950 Graphics Core
 - 400MHz 256-bit graphics core
 - Up to 10.6 GB/sec memory bandwidth with DDR2 667 MHz system memory
 - 1.6 GPixels/sec and 1.6 GTexels/sec fill rate
 - 192 MB maximum video memory
 - 2048 x 1536 at 75 Hz maximum resolution
 - Dynamic Display Modes for flat-panel, wide-screen and Digital TV support
 - Operating systems supported: Microsoft® Windows® XP, Windows® XP 64-bit, Media Center Edition, Windows 2000; Linux-compatible (Xfree86 source available)
- High Performance 3D
 - Up to 4 pixels per clock rendering
 - Microsoft® DirectX® 9 Hardware Acceleration Features:
 - Pixel Shader 2, Volumetric Textures, Shadow Maps,
 - Slope Scale Depth Bias, Two-Sided Stencil
 - Microsoft® DirectX® 9 Vertex Shader 3.0 and Transform and Lighting supported in SW through highly optimized
 - Processor Specific Geometry Pipeline (PSGP)
 - Texture Decompression for DirectX® and OpenGL®
 - OpenGL® 1.4 support with ARB extensions
- Advanced Display Technology
 - Consumer Electronic display (Digital TV) support

WSB-9452 PICMG 1.0 CPU Card

- Two Serial Digital Video Out (SDVO) ports for flat-panel monitors and/or TV-out support via ADD2 cards
- Support for Intel Media Expansion Cards, providing TV out and PVR capability
- Interlaced Display output support
- High Quality Media Support
 - High Definition Hardware Motion Compensation to support HD hi-bitrate MPEG2 media playback
 - Up and Down Scaling of Video Content
 - HD Content Decode – up to two stream support
 - 5x3 Overlay Filtering

2.4.2 Analog VGA

The on-board analog VGA has the following features.

- Supports 400MHz, 24-bit RAMDAC (RAM digital to analog converter)
- Supports displays with resolutions up to 2048x1536 pixels

2.4.3 Digital LVDS

The on-board digital LVDS has the following features.

- Supports dual-channel 24-bit LVDS for TFT Panels up to UXGA/WUXGA
- Compliant with ANSI/TIA/EIA-644-2001 SPEC.

2.4.4 Digital Visual Interface (DVI)

The DVI interface on supported models (see **Table 1-1**) has the following features.

- Supports DVI 1.0 up to UXGA with Silcon Image PanelLink[®] Technology

2.5 Data Flow

Figure 2-1 shows the data flow between the user-installed socket 478 CPU, the two on-board chipsets and other components installed on the CPU card are described in the following sections of this chapter.

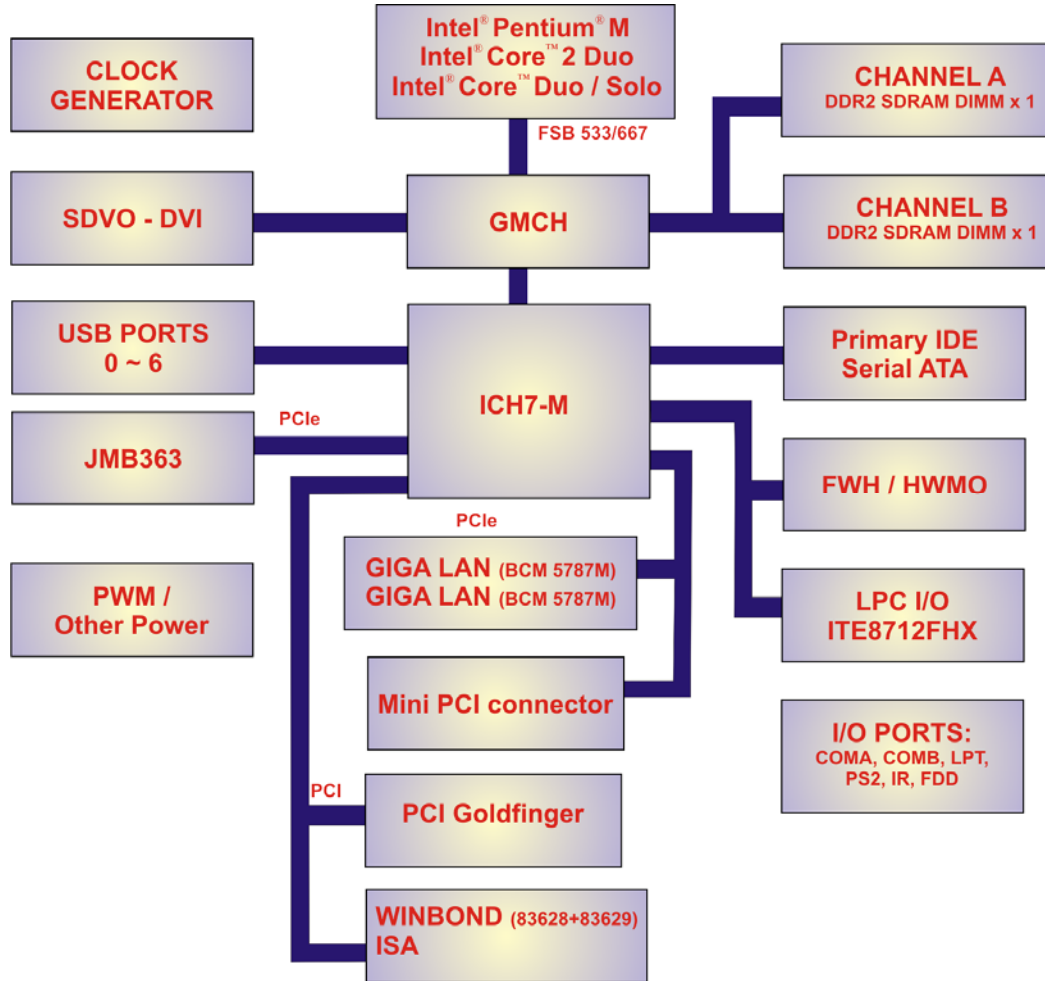

Figure 2-1: Data Flow Block Diagram

2.6 Memory Support



WARNING:

When installing a memory module, make sure a DDR2 memory module is used. A DDR memory module may cause permanent damage to the system and severe injury to the user.

The WSB-9452 CPU has two 240-pin dual inline memory module (DIMM) sockets that support up to two unbuffered DDR2 DIMMs with the following specifications:

- **Maximum RAM:** 4GB (2GB module in each slot)
- **DIMM Transfer Rates:** 667MHz, 533MHz, 400MHz
- Up to 10.6 GB/sec memory bandwidth

2.7 PCI Bus Interface Support

The PCI bus on the WSB-9452 CPU card has the following features:



NOTE:

The WSB-9452 does not support ISA DMA and ISA Bus Master function. Before purchasing your ISA device, please confirm with your vendor that your ISA card is supported by the CPU board.

- 33MHz Revision 2.3 is implemented
- Up to four external bus masters are supported
- 2.X ISA bus interface supported
- Three fully compatible ISA slots without buffering supported

2.8 GbE Ethernet Connection

The two GbE controllers (Broadcom BCM5787) on the WSB-9452 CPU card connect to two 10/100/1000Mb/s Ethernet RJ-45 LAN ports on the rear panel. The BCM5787 is a seventh generation 10/100/1000BASE-T Ethernet LAN controller solution for high performance network applications. The device combines a triple-speed IEEE 802.3 compliant Media Access Controller (MAC) with a triple-speed Ethernet transceiver, PCIe bus interface, and on-chip buffer memory in a single device. The device is fabricated in a 1.2V CMOS process providing a low-power system solution. The GbE controllers come with the following features:

- Integrated 10/100/1000 transceiver
- 10/100/1000 full/half-duplex MAC
- Automatic MDI crossover function
- Supports PCIe v1.0a
- Wake-on-LAN support meeting the ACPI requirements
- Statistics for SNMP MIB II, Ethernet-like MIB and Ethernet MIB (802.3z, clause 30)
- Serial EEPROM or serial flash supported
- JTAG supported
- 196-FBGA package

2.9 Drive Interfaces

The WSB-9452 and WSB-9452DVI models support the following drive interfaces:

- 2 x SATA drives
- 1 x IDE channel supports two Ultra ATA 100/66/33 devices
- 1 x FDD

The WSB-9452S and WSB-9452SDVI models support the following drive interfaces:

- 2 x SATA drives
- 2 x SATA II drives (Jmicron JMB363 chipset supports SATA3/SATA4 with RAID 0, RAID 1, and JBOD configurations)
- 2 x IDE channels support four Ultra ATA 100/66/33 devices

WSB-9452 PICMG 1.0 CPU Card

- 1 x FDD

2.9.1 SATA Drives

The WSB-9452 and WSB-9452DVI models support the following SATA drive interfaces:

- 2 x SATA drives with transfer rates up to 150 MB/s with the ICH7-M Southbridge chipset

The WSB-9452S and WSB-9452SDVI models support the following SATA drive interfaces:

- 2 x SATA drives with transfer rates up to 150 MB/s with the ICH7-M Southbridge chipset
- 2 x SATA II drives with transfer rates up to 300 MB/s with the Jmicron JMB363 chipset

2.9.2 IDE HDD Interfaces

The IDE controller on the ICH7-M Southbridge chipset integrated on the CPU card supports two HDDs (WSB-9452 and WSB-9452DVI models) or four HDDs (WSB-9452S and WSB-9452SDVI models) with the following specifications:

- Supports PIO IDE transfers up to 16MB/s
- Supports the following Ultra ATA devices:
 - **Ultra ATA/33**, with data transfer rates up to 33MB/s
 - **Ultra ATA/66**, with data transfer rates up to 66MB/s
 - **Ultra ATA/100**, with data transfer rates up to 100MB/s

2.9.3 Floppy Disk Drive (FDD)

The WSB-9452 CPU card supports a single FDD. The following FDD formats are compatible with the board.

- 5.25": 360KB and 1.2MB
- 3.5": 720KB, 1.44MB and 2.88MB

2.10 SATA II and RAID Functionality (SATA3 and SATA4 only)

Two SATA II channels and their associated RAID functionality are only available on the WSB-9452S and WSB-9452SDVI models. These models come with an on-board Jmicron JMB363 PCI-E to two-port SATA II and one-port parallel ATA (PATA) host controller. The Jmicron JMB363 supports the following SATA II / PATA features:

- Two-port 300 MB/s SATA II interface
- Two independent SATA II channels (separate logic and FIFO)
- Native Command Queue (NCQ) on SATA II port
- Hot Plugging like USB on SATA II port
- SATA II Gen1m and Gen2m (External SATA Connection, eSATA)
- Port Multiplier with Command-based Switching on SATA II port
- Up to UDMA6 PATA transfer mode
- Up to four storage device connection
- RAID 0, 1, 0+1, JBOD configuration

2.11 Serial Ports

The WSB-9452 CPU card has two high-speed UART serial ports, configured as COM1 and COM2. The serial ports have the following specifications.

- 16C550 UART with 16-byte FIFO buffer
- 115.2Kbps transmission rate

2.12 Real Time Clock

256-byte battery backed CMOS RAM

2.13 System Monitoring

The WSB-9452 CPU card is capable of self-monitoring various aspects of its operating status including:

- CPU, chipset, and battery voltage, +3.3V, +5V, and +12V
- RPM of cooling fans
- CPU and board temperatures (by the corresponding embedded sensors)

2.14 Infrared Data Association (IrDA) Interface

The WSB-9452 CPU card IrDA supports the following interfaces.

- Serial Infrared (SIR)
- Amplitude Shift Keyed Infrared (ASKIR)

If you want to use the IrDA port, you have to configure SIR or ASKIR mode in the BIOS under **Super IO devices**. The normal RS-232 COM2 will be disabled.

2.15 USB Interfaces

The WSB-9452 CPU card has seven USB interfaces, six internal and one external. The USB interfaces support USB 2.0.

2.16 BIOS

The WSB-9452 CPU card uses a licensed copy of AMI BIOS. The features of the flash BIOS used are listed below:

- SMIBIOS (DMI) compliant
- Console redirection function support
- PXE (**P**re-**B**oot **E**xecution **E**nvironment) support
- USB booting support

2.17 Operating Temperature and Temperature Control

The maximum and minimum operating temperatures for the WSB-9452 CPU card are listed below.

- Minimum Operating Temperature: 0°C (32°F)
- Maximum Operating Temperature: 60°C (140°F)

A cooling fan and heat sink must be installed on the CPU. Thermal paste must be smeared on the lower side of the heat sink before it is mounted on the CPU. Heat sinks are also mounted on the Northbridge and Southbridge chipsets to ensure the operating temperature of these chips remain low.

2.18 Optional Audio Interface

The WSB-9452 CPU card does not come with an on-board Codec but the Intel® ICH7-M chipset has an Audio Codec (AC'97 / HDA) controller. A connector on the CPU card can be used to connect the ICH7-M audio controllers to an external Codec.

2.19 Power Consumption

Table 2-2 shows the power consumption parameters for the WSB-9452 CPU card when a 2GHz Intel® Core™ Duo processor is running with two 1GB DDR2 667MHz SDRAM memory modules.

Voltage	Current
5V	4.15A
+12V	1.29A

Table 2-2: Power Consumption

2.20 Packaged Contents and Optional Accessory Items

2.20.1 Package Contents

When you unpack the WSB-9452 CPU card you should find the following components.

- 1 x WSB-9452 single board computer
- 1 x Mini jumper pack
- 1 x ATA 66/100 flat cable
- 1 x Dual RS-232 cable
- 2 x SATA cables
- 1 x SATA power cable
- 1 x Keyboard/ PS2 mouse Y cable
- 1 x USB cable
- 1 x Utility CD
- 1 x QIG (quick installation guide)

2.20.2 Special Items

The following additional items are shipped with the WSB-9452S and WSB-9452SDVI CPU card models.

- 2 x SATA cables
- 1 x SATA power cable

2.20.3 Optional Accessory Items

The items shown in the list below are separately purchased optional accessory items.

- DVI cable
- Audio Kit
- CPU Cooler
- FDD cable
- LPT cable

Chapter

3

Unpacking

3.1 Anti-static Precautions



WARNING:

Failure to take ESD precautions during the installation of the WSB-9452 may result in permanent damage to the WSB-9452 and severe injury to the user.

Electrostatic discharge (ESD) can cause serious damage to electronic components, including the WSB-9452. Dry climates are especially susceptible to ESD. It is therefore critical that whenever the WSB-9452, or any other electrical component is handled, the following anti-static precautions are strictly adhered to.

- **Wear an anti-static wristband:** - Wearing a simple anti-static wristband can help to prevent ESD from damaging the board.
- **Self-grounding:**- Before handling the board touch any grounded conducting material. During the time the board is handled, frequently touch any conducting materials that are connected to the ground.
- **Use an anti-static pad:** When configuring the WSB-9452, place it on an anti-static pad. This reduces the possibility of ESD damaging the WSB-9452.
- **Only handle the edges of the PCB:-** When handling the PCB, hold the PCB by the edges.

3.2 Unpacking

3.2.1 Unpacking Precautions

When the WSB-9452 is unpacked, please do the following:

- Follow the anti-static precautions outlined in Section 3.1.
- Make sure the packing box is facing upwards so the WSB-9452 does not fall out of the box.
- Make sure all the components shown in Section 3.3 are present.

3.3 Unpacking Checklist





NOTE:

If some of the components listed in the checklist below are missing, please do not proceed with the installation. Contact the IEI reseller or vendor you purchased the WSB-9452 from or contact an IEI sales representative directly. To contact an IEI sales representative, please send an email to sales@iei.com.tw.

3.3.1 Package Contents

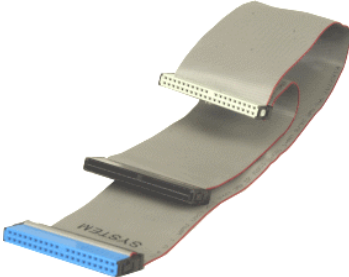
The WSB-9452 is shipped with the following components:

Quantity	Item and Part Number	Image
1	WSB-9452 CPU Card	
1	ATA 66/100 flat cable (P/N: 32200-000052-RS)	
1	Dual RS-232 cable (P/N: 19800-000051-RS)	







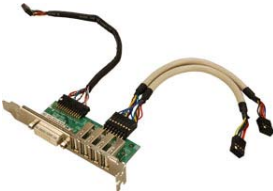

1	IO-KIT (DVI model only) (P/N: IO-KIT-001)	
1	KB/MS PS/2 Y-cable (P/N: 32000-000138-RS)	
2	SATA cables (P/N: 32000-062800-RS)	
1	SATA power cables (P/N: 32100-088600-RS)	
1	Mini jumper Pack	
1	Quick Installation Guide	
1	Utility CD	
1	USB cable (P/N: CB-USB02-RS)	

Table 3-1: Package List Contents

WSB-9452 PICMG 1.0 CPU Card

3.4 Optional Items







<p>CPU cooler (P/N: CF-479B-RS)</p>	
<p>Audio kit (P/N: AC-KIT-833HD-R10)</p>	
<p>Audio kit_ 5.1 Channel (P/N: AC-KIT08R-R10)</p>	
<p>ATX 12V Cable (P/N: 32100-087100-RS)</p>	
<p>FDD cable (P/N:32200-000017-RS)</p>	
<p>LPT cable (P/N:19800-000049-RS)</p>	

Table 3-2: Package List Contents

Chapter

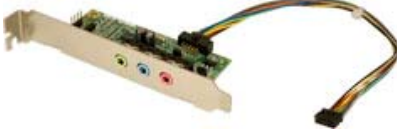
4

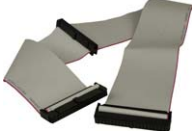
Connectors and Jumpers

WSB-9452 PICMG 1.0 CPU Card

4.1 Peripheral Interface Connectors

The locations of the peripheral interface connectors are shown in **Section 4.1.1**. A complete list of all the peripheral interface connectors can be seen in **Section 4.2**.

4.1.1 WSB-9452 CPU card Layout

Table 4-1 shows the on-board peripheral connectors, backplane peripheral connectors and on-board jumpers.

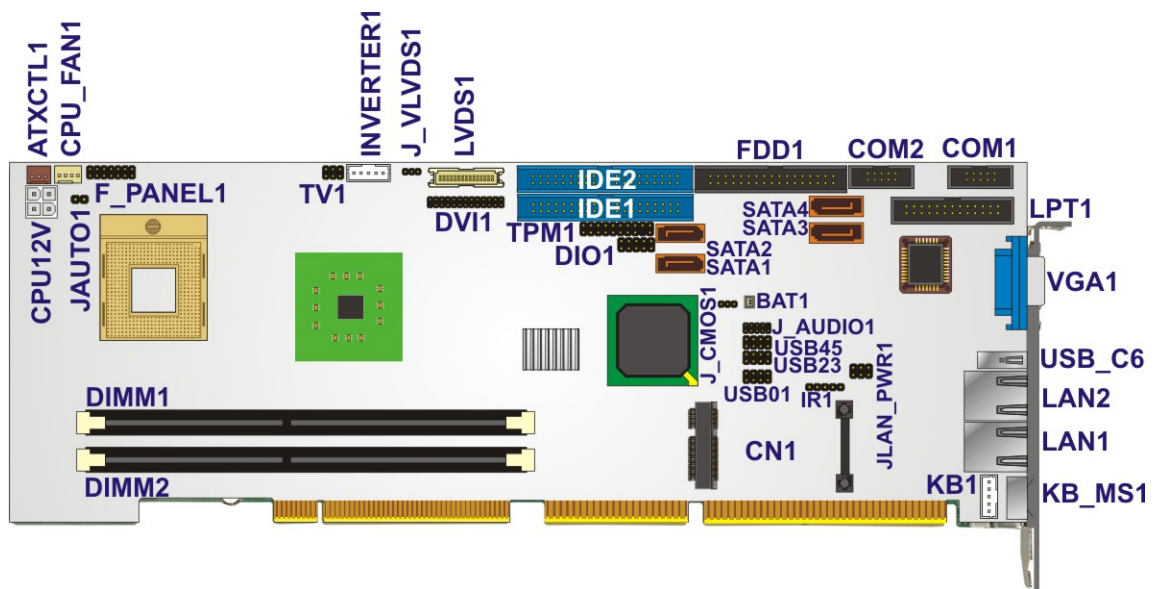

Table 4-1: Connector and Jumper Locations

4.1.2 Peripheral Interface Connectors

Table 4-2 lists the peripheral interface connectors on the WSB-9452 CPU card. Detailed descriptions of these connectors can be found in **Section 4.2**.

Label	Connector	Type
CPU12V1	ATX-12V CPU Power Source	4-pin terminal block
J_AUDIO1	Audio Module Connector	10-pin header
ATXCTL1	Backplane to Mainboard Power Connector	3-pin wafer connector
BAT1	Battery Connector	2-pin wafer connector
CPU_FAN1	CPU Fan Connector	4-pin wafer connector
DIO1	Digital I/O Connector	10-pin header
DVI1	Digital Visual Interface Connector	25-pin header
FDD1	FDD Connector	34-pin box header
F_PANEL1	Front Panel Connector	14-pin header
IDE1, IDE2	IDE Connectors (Primary)	40-pin box header
INVERTER1	Inverter Connector	5-pin wafer connector
IR1	IrDA Infrared Interface Connector	5-pin header
KB1	Keyboard Connector	4-pin wafer connector
LVDS1	LVDS Panel Connector	30-pin crimp connector
LPT1	Parallel Port Connector	25-pin box header
CN1	PCI-Express Mini Card	52-pin PCIe Mini Card slot
COM1	RS-232 Serial Port Connectors	10-pin box header
COM1	RS-232 Serial Port Connectors	10-pin box header
SATA1	Serial ATA Connectors	7-pin SATA connector

SATA2	Serial ATA Connectors	7-pin SATA connector
SATA3	Serial ATA Connectors	7-pin SATA connector
SATA4	Serial ATA Connectors	7-pin SATA connector
TPM1	Trusted Platform Module Connector	20-pin header
TV1	TV Out Connector	6-pin header
USB01	USB Connectors	8-pin header
USB23	USB Connectors	8-pin header
USB45	USB Connectors	8-pin header

Table 4-2: Peripheral Interface Connectors

4.1.3 External Peripheral Interface Connectors

Table 4-3 lists the external peripheral interface connectors on the WSB-9452. Detailed descriptions of these connectors can be found in **Section 4.3**.

Connector	Type	Label
Ethernet connector	RJ-45 connector	LAN1
Ethernet connector	RJ-45 connector	LAN2
Keyboard/mouse connector	MINI-DIN connector	KB_MS1
USB connector	USB 2.0 connector	USB_C6
VGA connector	HD-D-sub 15 female connector	VGA1

Table 4-3: External Peripheral Interface Connectors

4.1.4 On-board Jumpers

Table 4-4 lists the on-board jumpers. Detailed descriptions of these jumpers can be found in **Section 5.5**.

Label	Connector	Type
J_CMOS1	CMOS state setting	3-pin header
J_LVDS1	L CD Voltage Selector	3-pin header
JAUTO1	AT/ATX mode select	2-pin header
JLAN_PWR1	LAN power select	6-pin header

Table 4-4: On-board Jumpers

4.2 Internal Peripheral Connectors

Internal peripheral connectors are found on the CPU card and are only accessible when the CPU card is outside of the chassis. This section has complete descriptions of all the internal peripheral connectors on the WSB-9452 CPU card.

4.2.1 ATX-12V Power Source Connector

- CN Label:** CPU12V1
- CN Type:** 4-pin terminal block
- CN Location:** See **Figure 4-1**
- CN Pinouts:** See **Table 4-5**

This connector supports the ATX-12V power supply.

WSB-9452 PICMG 1.0 CPU Card

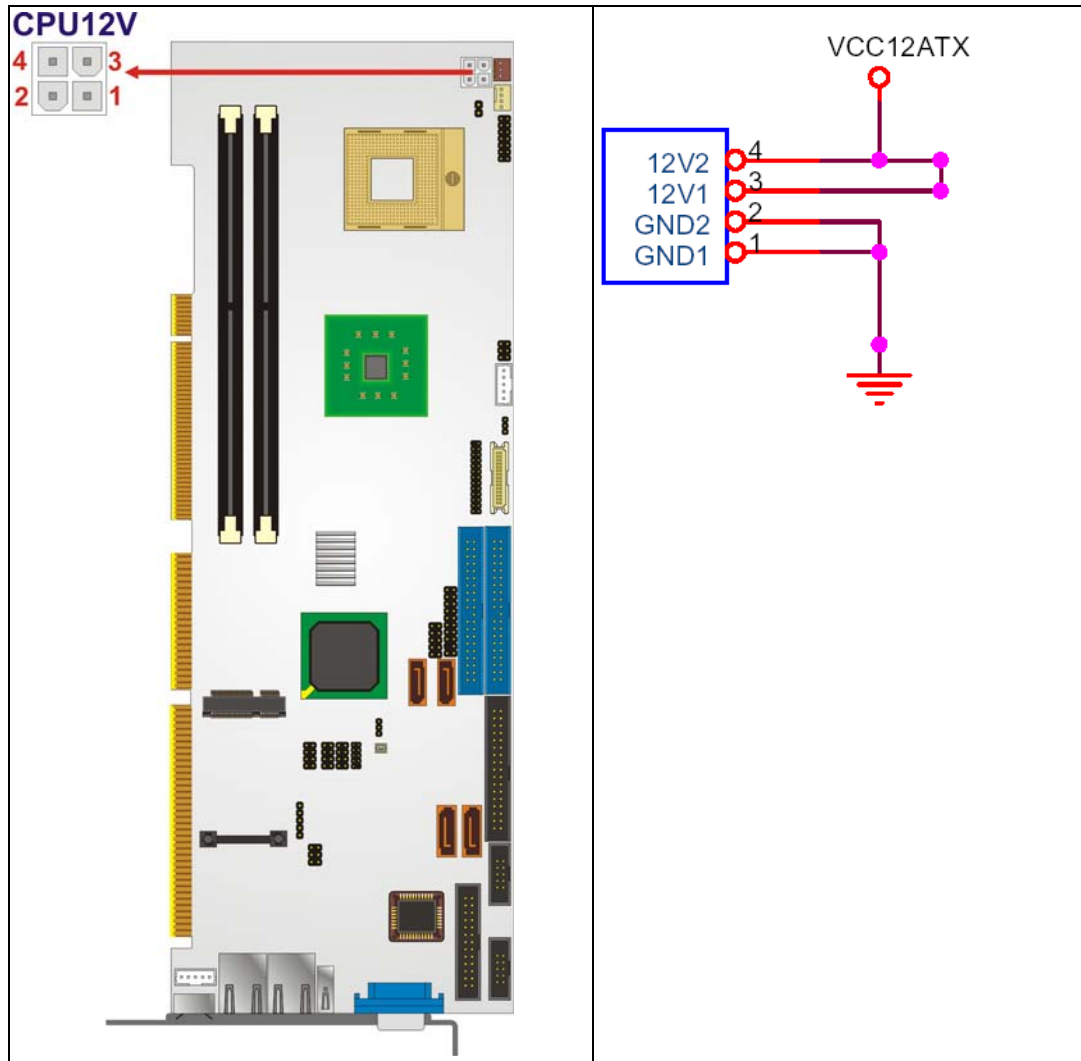

Figure 4-1: ATX-12V Connector Location

PIN NO.	DESCRIPTION	PIN NO.	DESCRIPTION
1	GND	2	GND
3	+12V	4	+12V

Table 4-5: ATX-12V Connector Pinouts

4.2.2 Audio Module Connector

- CN Label:** J_AUDIO1
- CN Type:** 10-pin header
- CN Location:** See Figure 4-2
- CN Pinouts:** See Table 4-6

The WSB-9452 CPU card does not have a built-in AC'97 audio codec. If your system needs audio then this connector must be connected to an external audio module (AC-KIT-08R).

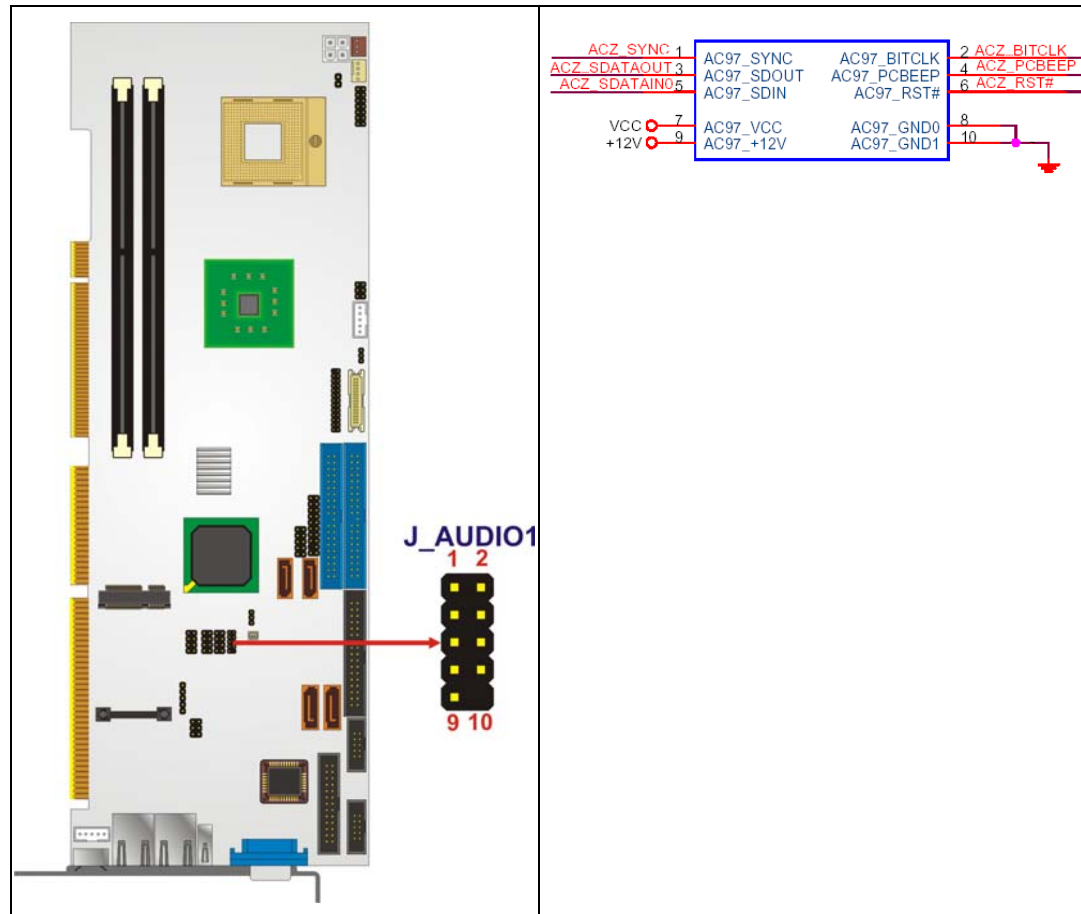

Figure 4-2: Audio Connector Location

PIN NO.	DESCRIPTION	PIN NO.	DESCRIPTION
1	AC97_SYNC	2	AC97_BITCLK
3	AC97_SDOUT	4	AC97_PCBEEP
5	AC97_SDIN	6	AC97_RST#
7	AC97_VCC	8	AC97_GND
9	AC97_12V	10	AC97_GND

Table 4-6: Audio Connector Pinouts

4.2.3 Backplane to Mainboard Power Connector

- CN Label:** ATXCTL1
- CN Type:** 3-pin wafer connector
- CN Location:** See **Figure 4-3**
- CN Pinouts:** See **Table 4-7**

Connects a power source from a backplane with an ATX Connector.

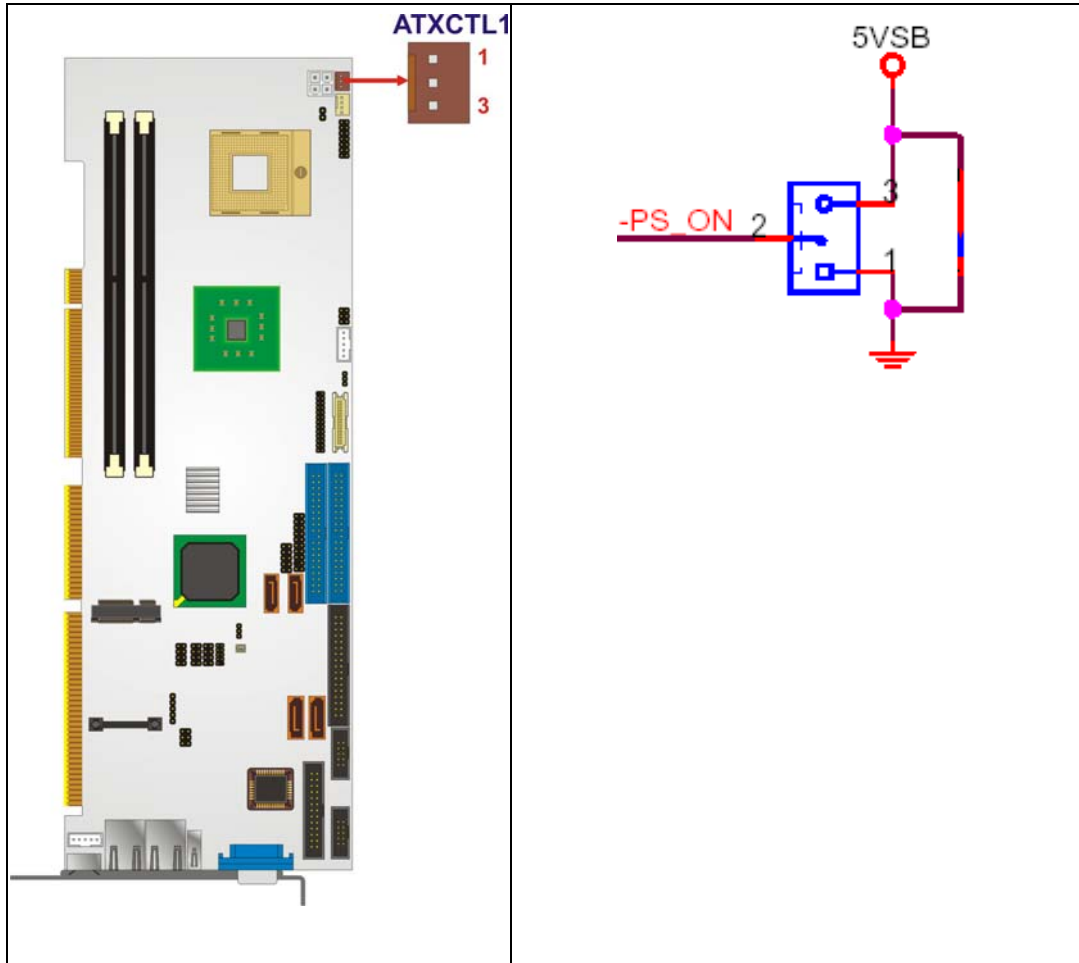

Figure 4-3: Backplane to Mainboard Power Connector Location

PIN NO.	DESCRIPTION
1	Ground
2	PS_ON
3	5V Dual

Table 4-7: Backplane to Mainboard Power Pin Outs

WSB-9452 PICMG 1.0 CPU Card

4.2.4 Battery Connector

- CN Label:** BAT1
- CN Type:** 2-pin wafer connector
- CN Location:** See Figure 4-4
- CN Pinouts:** See Table 4-8

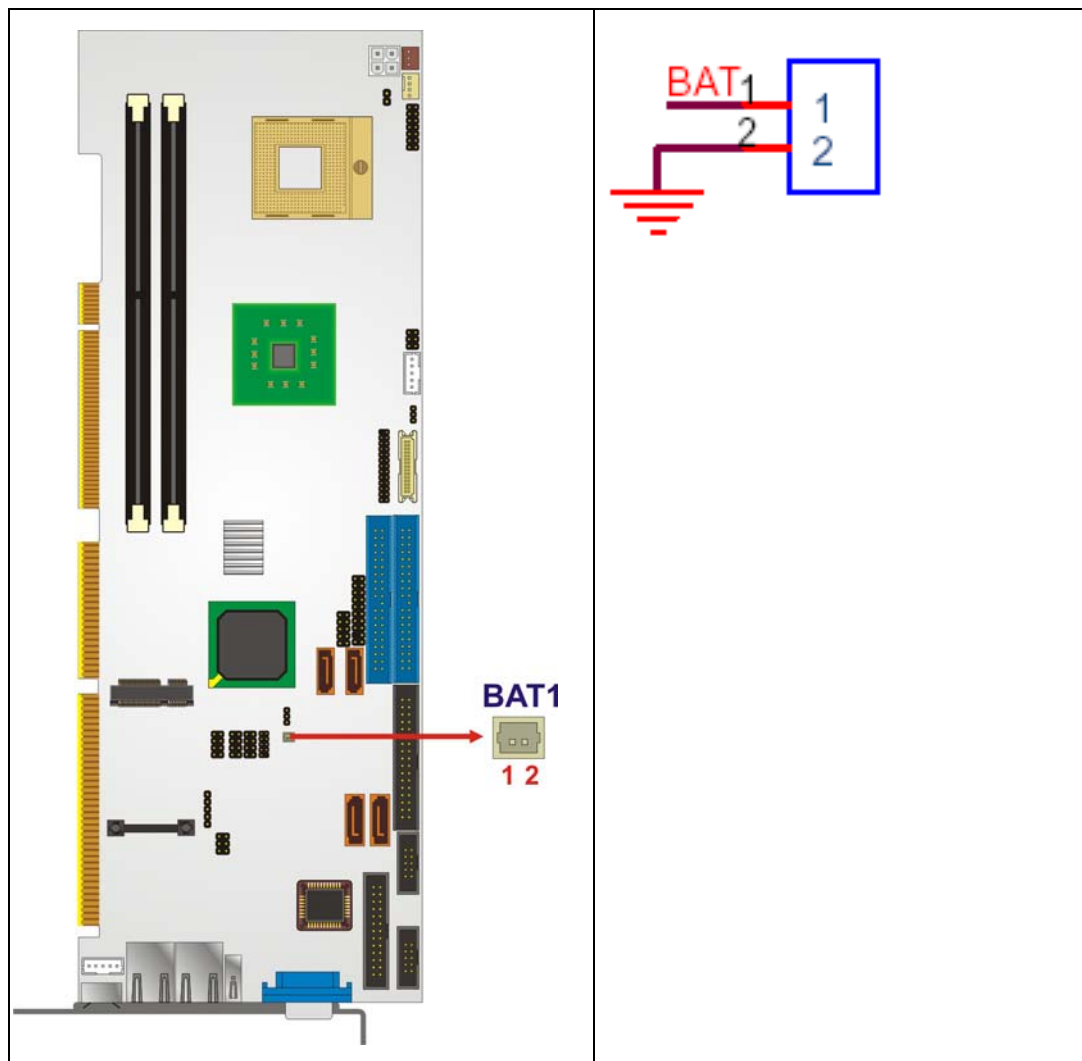

Figure 4-4: Battery Connector Location

PIN NO.	DESCRIPTION
1	BAT
2	GND

Table 4-8: Battery Connector Pinouts

4.2.5 CPU Fan Connector

- CN Label:** CPU_FAN1
- CN Type:** 4-pin wafer connector
- CN Location:** See **Figure 4-5**
- CN Pinouts:** See **Table 4-9**

The cooling fan connector provides a 12V, 500mA current to a CPU cooling fan. The connector has a "rotation" pin to get rotation signals from fans and notify the system so the system BIOS can recognize the fan speed. Please note that only specified fans can issue the rotation signals.

WSB-9452 PICMG 1.0 CPU Card

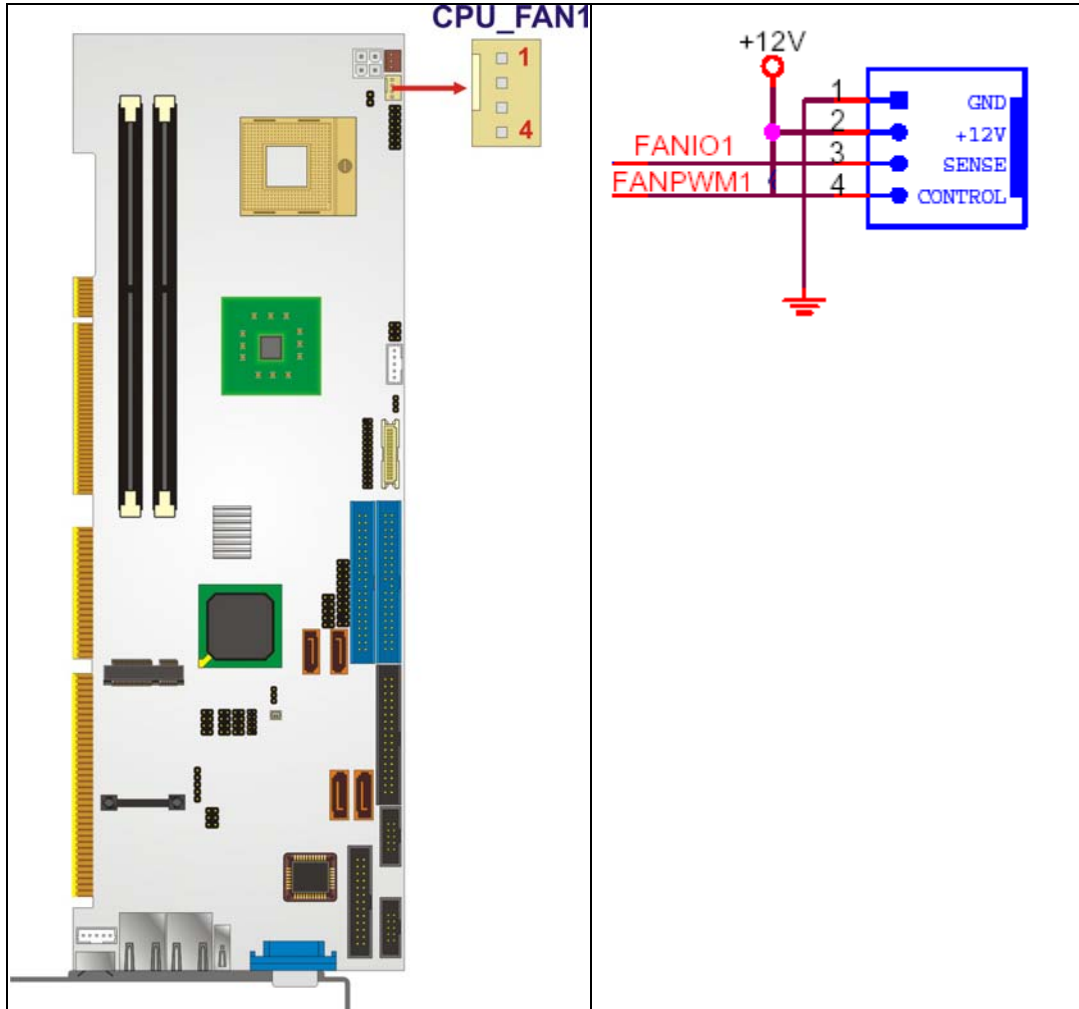

Figure 4-5: CPU Fan Connector Location

PIN	DESCRIPTION
1	Ground
2	+12V
3	Rotation Signal
4	Control

Table 4-9: CPU Fan Connector Pinouts

4.2.6 Digital Input/Output (DIO) Connector

- CN Label:** DIO1
- CN Type:** 10-pin header
- CN Location:** See Figure 4-6
- CN Pinouts:** See Table 4-10

The DIO connector is managed through a Super I/O chip. The DIO connector pins are user programmable.

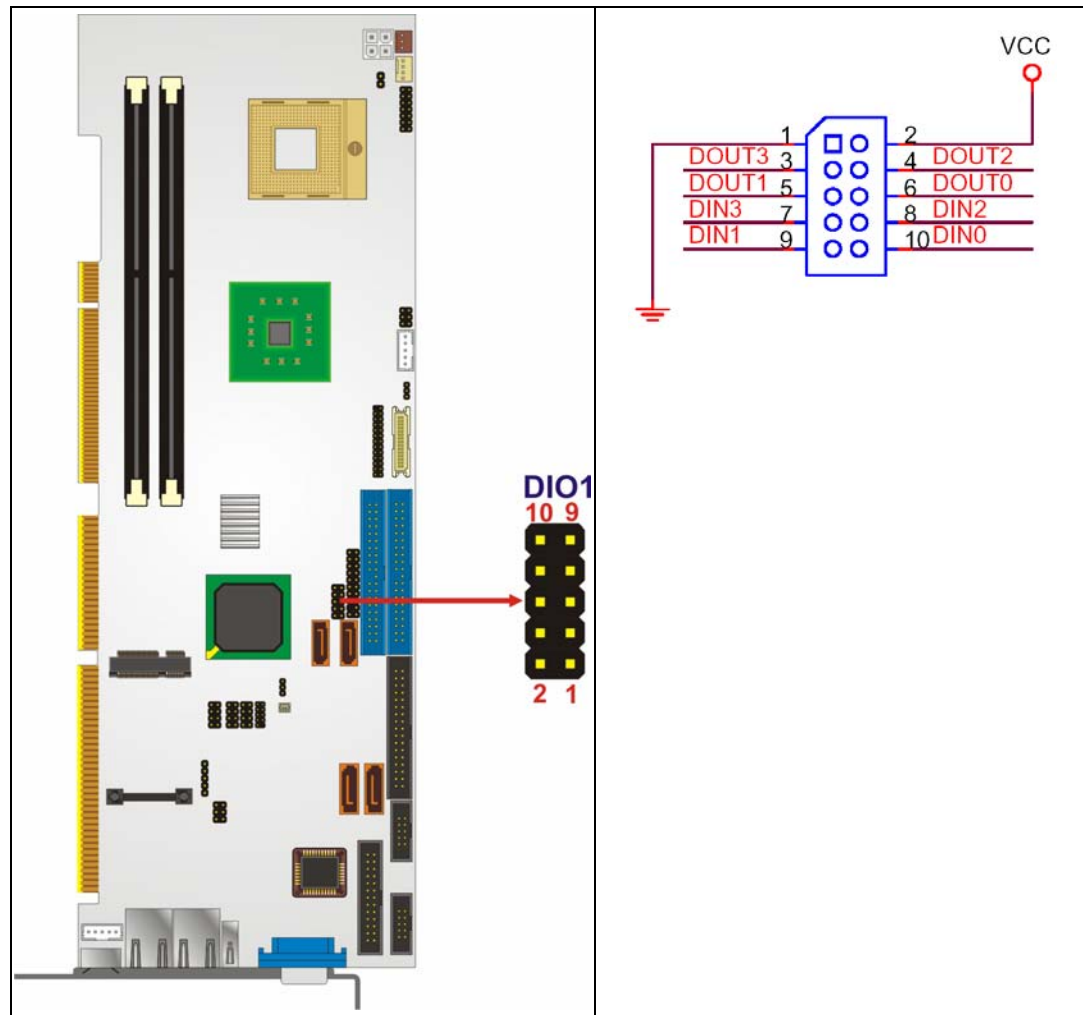

Figure 4-6: DIO Connector Location

PIN NO.	DESCRIPTION	PIN NO.	DESCRIPTION
1	Ground	2	VCC
3	Output 3	4	Output 2
5	Output 1	6	Output 0
7	Input 3	8	Input 2
9	Input 1	10	Input 0

Table 4-10: DIOConnector Pinouts

4.2.7 DVI (Digital Visual Interface) Connector

- CN Label:** DVI1
- CN Type:** 25-pin header
- CN Location:** See **Figure 4-7**
- CN Pinouts:** See **Table 4-11**

The WSB-9452DVI and WSB-9452SDVI models provide a digital visual interface for digital display. Optional accessory IO-KIT-001 modules can be selected to connect to external DVI devices.

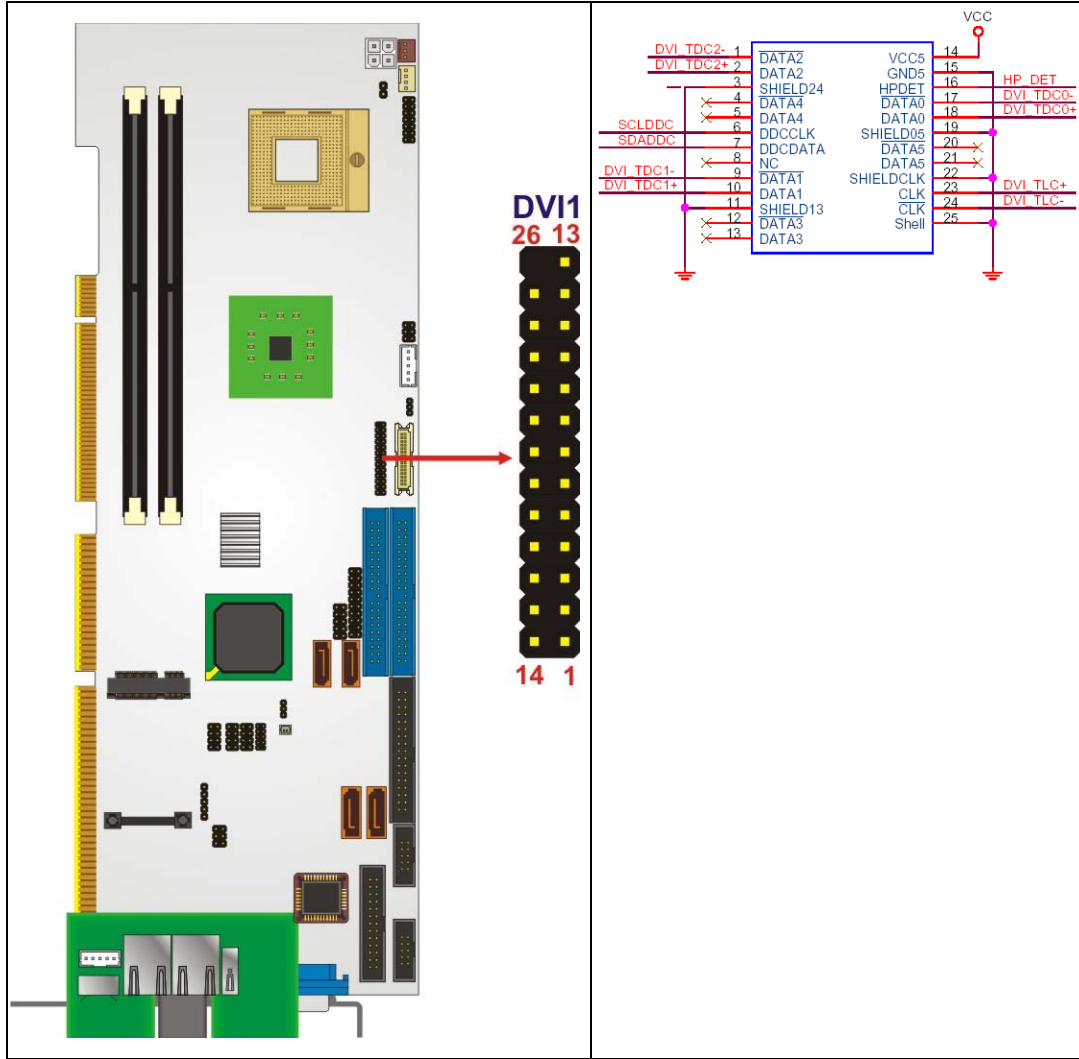

Figure 4-7: DVI Connector Location

PIN NO.	DESCRIPTION	PIN NO.	DESCRIPTION
1	Data 2-	14	+5V Power
2	Data 2+	15	GND
3	GND	16	Hot Plug Detect
4	N/C	17	Data 0-
5	N/C	18	Data 0+
6	DDC Clock	19	GND
7	DDC Data	20	N/C
8	N/C	21	N/C

WSB-9452 PICMG 1.0 CPU Card

9	Data 1-	22	GND
10	Data 1+	23	Clock +
11	GND	24	Clock -
12	N/C	25	GND
13	N/C		

Table 4-11: DVI Connector Pinouts

4.2.8 FDD Connector

- CN Label:** FDD1
- CN Type:** 34-pin header
- CN Location:** See **Figure 4-8**
- CN Pinouts:** See **Table 4-12**

The WSB-9452 is shipped with a 34-pin daisy-chain drive connector cable. This cable can be connected to the FDD connector.

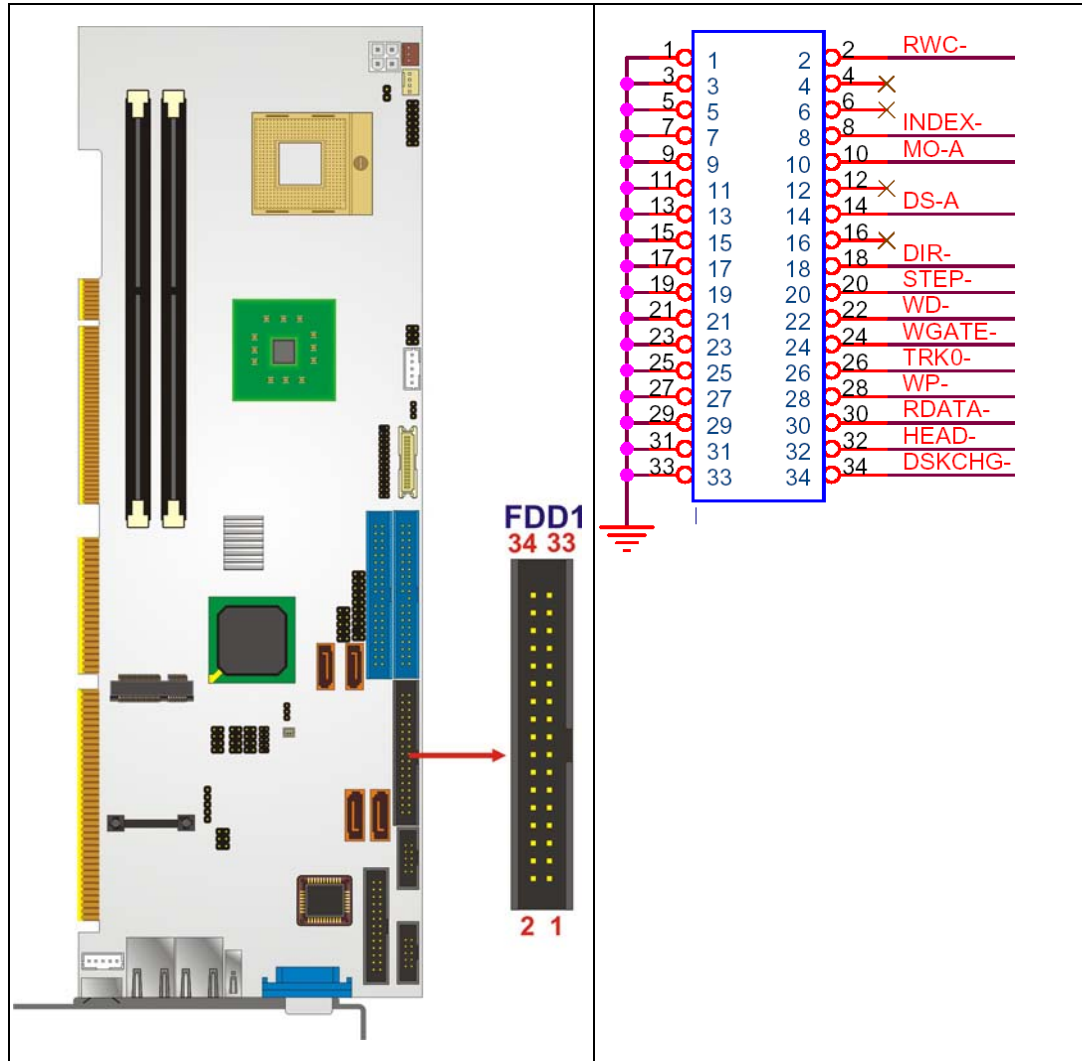

Figure 4-8: FDD Connector Location

PIN	DESCRIPTION	PIN	DESCRIPTION
1	GND	2	REDUCE WRITE
3	GND	4	N/C
5	N/C	6	N/C
7	GND	8	INDEX#
9	GND	10	MOTOR ENABLE A#
11	GND	12	DRIVE SELECT B#
13	GND	14	DRIVE SELECT A#

WSB-9452 PICMG 1.0 CPU Card

15	GND	16	MOTOR ENABLE B#
17	GND	18	DIRECTION#
19	GND	20	STEP#
21	GND	22	WRITE DATA#
23	GND	24	WRITE GATE#
25	GND	26	TRACK 0#
27	GND	28	WRITE PROTECT#
29	GND	30	READ DATA#
31	GND	32	SIDE 1 SELECT#
33	GND	34	DISK CHANGE#

Table 4-12: FDD Connector Pinouts

4.2.9 Front Panel Connector

- CN Label:** F_PANEL1
- CN Type:** 14-pin header
- CN Location:** See **Figure 4-9**
- CN Pinouts:** See **Table 4-13**

The system front panel connector connects to:

- the system chassis front panel LEDs
- the chassis speaker
- the power switch
- the reset button

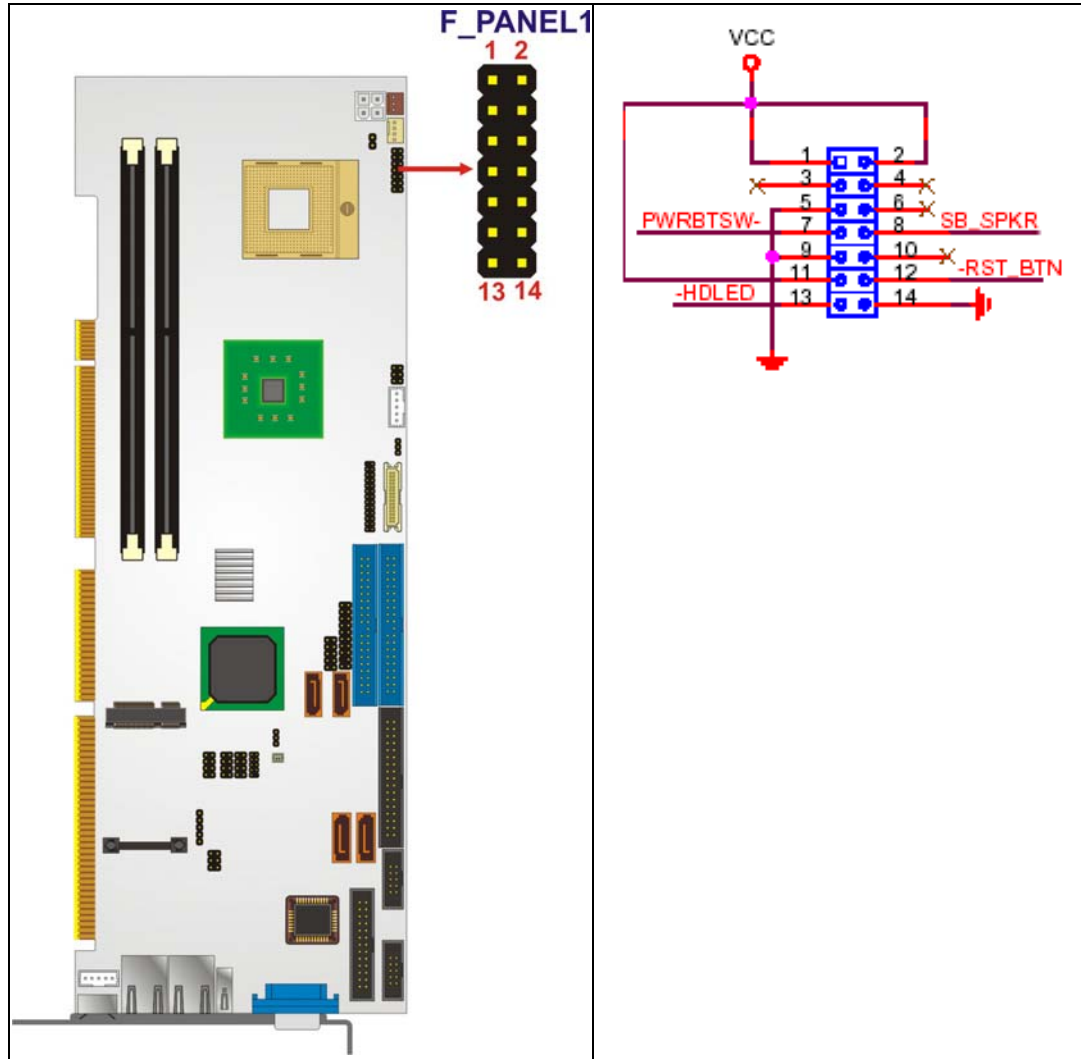

Figure 4-9: Front Panel Connector Location

FUNCTION	PIN	DESCRIPTION	FUNCTION	PIN	DESCRIPTION
Power LED	1	+5V	Speaker	2	+5V
	3	N/C		4	N/C
	5	GROUND		6	N/C
PWRBTN	7	PWRBTN+	8	Speaker	
	9	PWRBTN-	10	N/C	
HDDLED	11	+5V	RESET	12	Reset-
	13	HDLED-		14	GND

Table 4-13: Front Panel Connector Location

WSB-9452 PICMG 1.0 CPU Card

4.2.10 IDE Connectors

- CN Label:** IDE1, IDE2
- CN Type:** 40-pin box header
- CN Location:** See Figure 4-10
- CN Pinouts:** See Table 4-14

One IDE connector provides connectivity for two IDE devices. WSB-9452 and WSB-9452DVI models have one IDE connector. WSB-9452S and WSB-9452SDVI models have two IDE connectors.

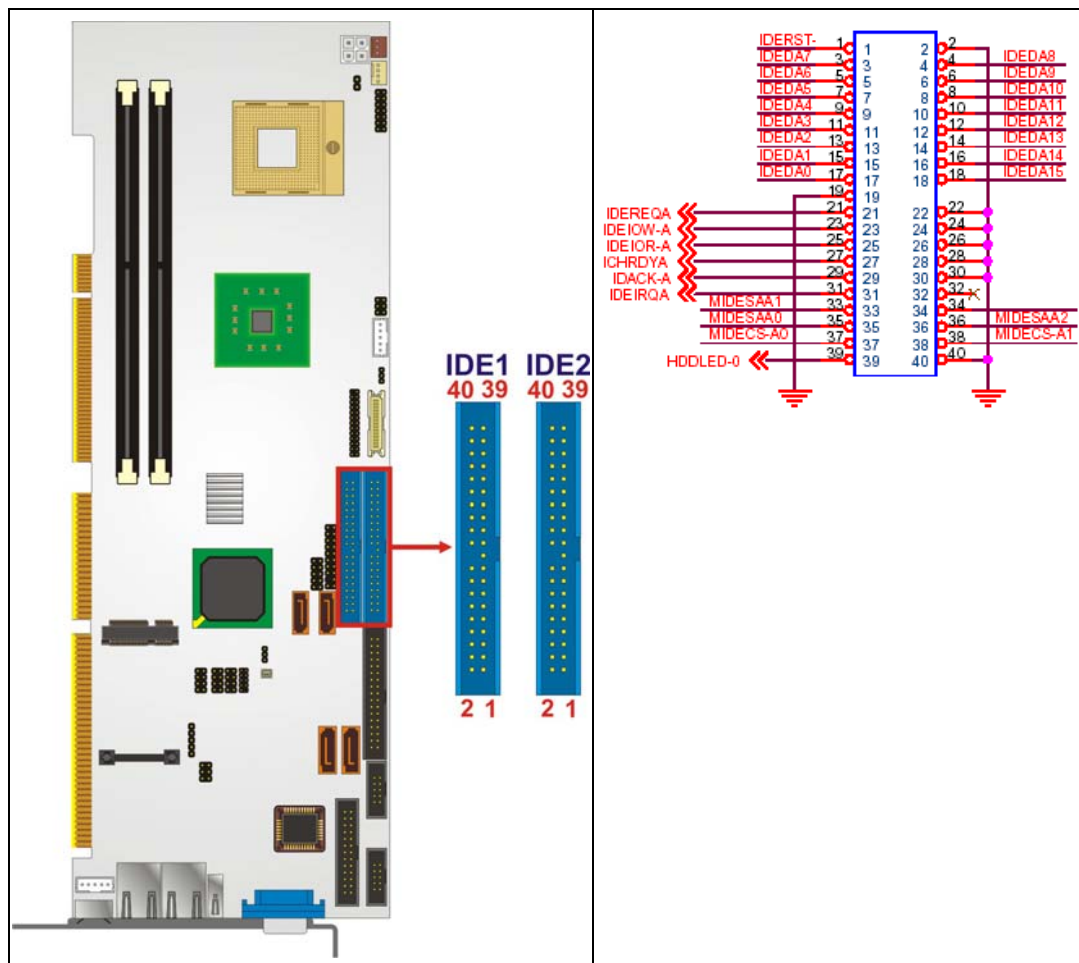

Figure 4-10: IDE Connectors Location

PIN	DESCRIPTION	PIN	DESCRIPTION
1	RESET#	2	GND
3	DATA 7	4	DATA 8
5	DATA 6	6	DATA 9
7	DATA 5	8	DATA 10
9	DATA 4	10	DATA 11
11	DATA 3	12	DATA 12
13	DATA 2	14	DATA 13
15	DATA 1	16	DATA 14
17	DATA 0	18	DATA 15
19	GND	20	N/C
21	IDE DRQ	22	GND
23	IOW#	24	GND
25	IOR#	26	GND
27	IDE CHRDY	28	BALE – DEFAULT
29	IDE DACK	30	GND
31	INTERRUPT	32	N/C
33	SA1	34	PDIAG#
35	SA0	36	SA2
37	HDC CS0#	38	HDC CS1#
39	HDD ACTIVE#	40	GND

Table 4-14: IDE Connector Pinouts

4.2.11 Inverter Connector

- CN Label:** INVERTER1
- CN Type:** 5-pin wafer connector
- CN Location:** See **Figure 4-11**
- CN Pinouts:** See **Table 4-15**

WSB-9452 PICMG 1.0 CPU Card

The inverter control connector enables power on/off backlight during the power saving mode.

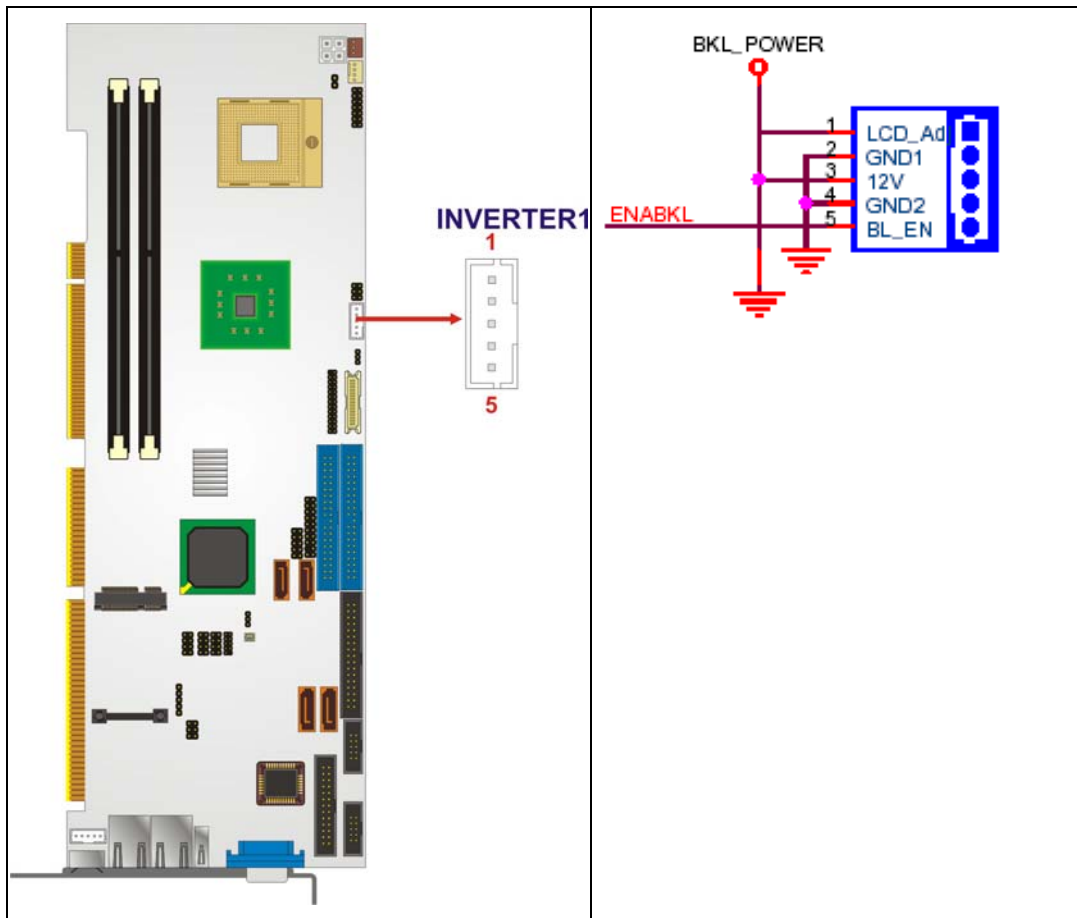

Figure 4-11: Inverter Connector Location

PIN	DESCRIPTION
1	BRIGHTNESS
2	GND1
3	12V
4	GND2
5	BL_EN

Table 4-15: Inverter Connector Pinouts

4.2.12 IrDA Interface Connector

- CN Label:** IR1
- CN Type:** 5-pin header
- CN Location:** See **Figure 4-12**
- CN Pinouts:** See **Table 4-16**

The integrated IrDA interface connector supports both the SIR and ASKIR infrared protocols.

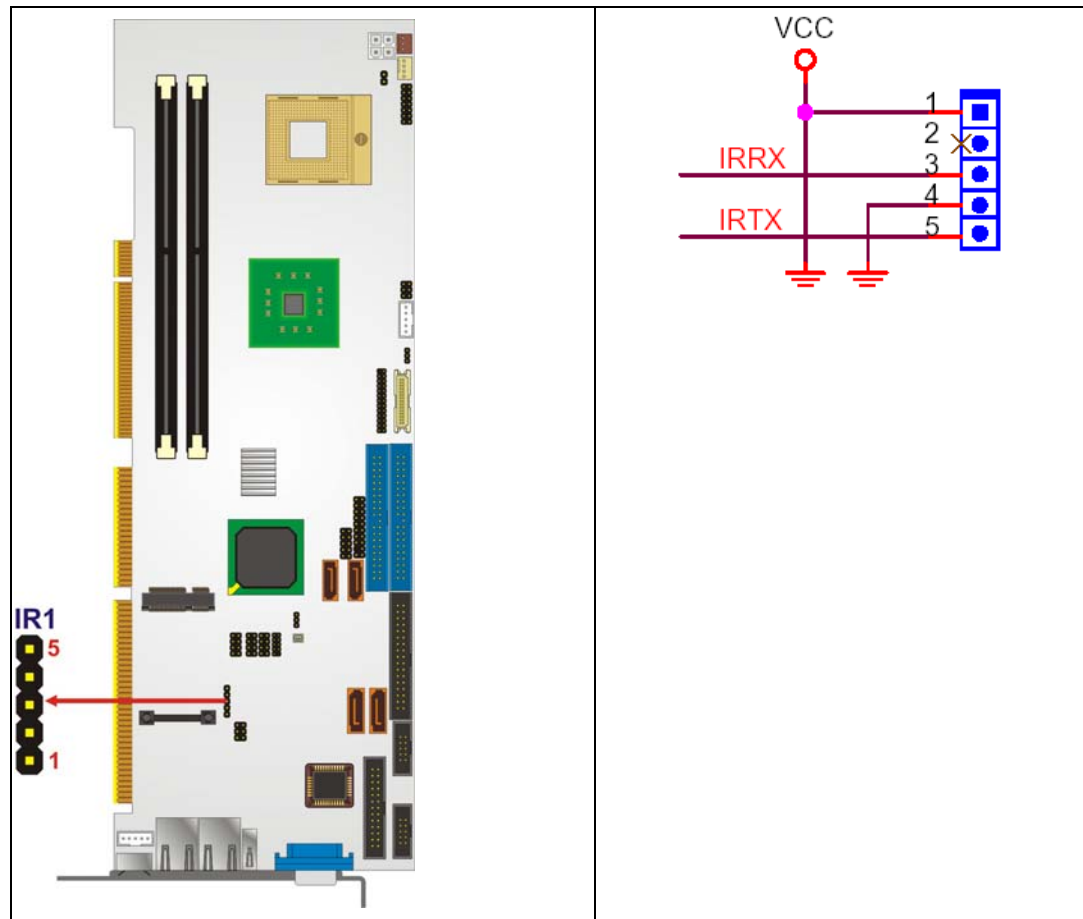

Figure 4-12: IrDA Interface Connector Location

PIN	DESCRIPTION
1	VCC
2	NC
3	IR-RX
4	GND
5	IR-TX

Table 4-16: IrDA Interface Connector Pinouts

4.2.13 Keyboard Connector

- CN Label:** KB1
- CN Type:** 4-pin wafer
- CN Location:** See **Figure 4-13**
- CN Pinouts:** See **Table 4-17**

For alternative application, a keyboard pin header connector is also available on board. This connector requires a special adapter cable.

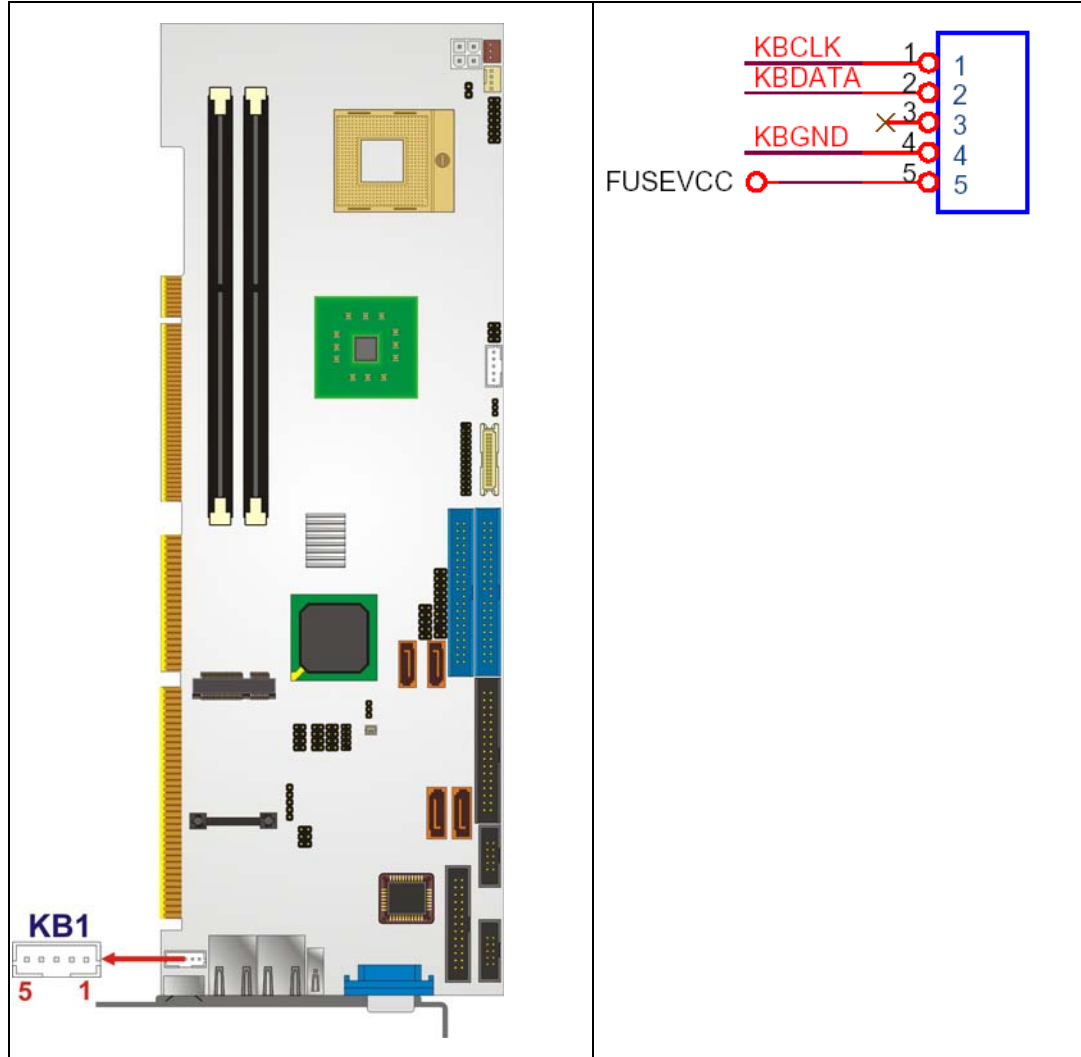

Figure 4-13: Keyboard Connector Location

PIN	DESCRIPTION
1	Keyboard Clock
2	Keyboard Data
3	NC
4	GND
5	VCC

Table 4-17: KB1 Connector Pinouts

WSB-9452 PICMG 1.0 CPU Card

4.2.14 LVDS Connector

- CN Label:** LVDS1
- CN Type:** 30-pin crimp connector
- CN Location:** See Figure 4-14
- CN Pinouts:** See Table 4-18

The LVDS connector allows for a 24-bit, dual-channel, low noise, low power, and low amplitude high-speed data connection between the CPU card and LCD panel.

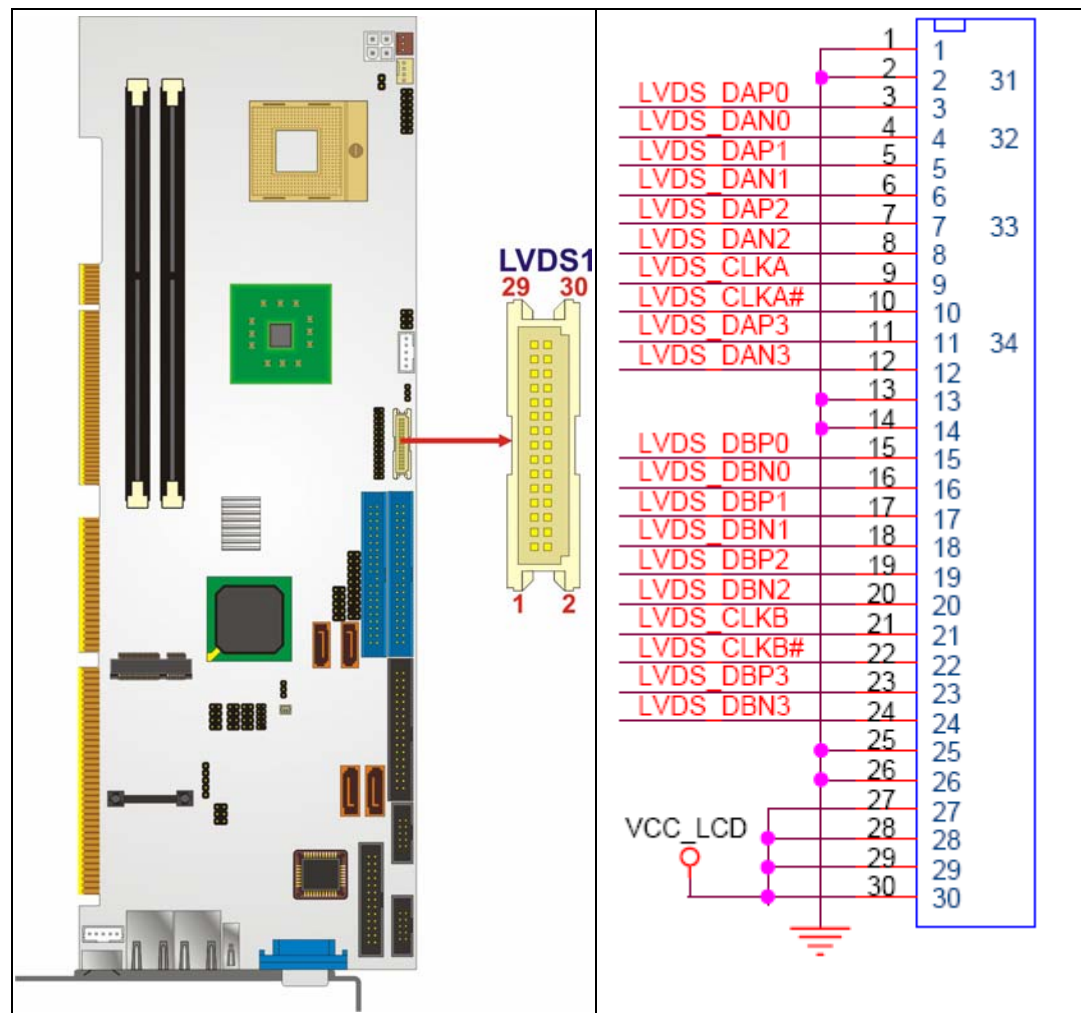

Figure 4-14: LVDS Connector Location

PIN	DESCRIPTION	PIN	DESCRIPTION
1	GND	2	GND
3	A_Y0	4	A_Y0#
5	A_Y1	6	A_Y1#
7	A_Y2	8	A_Y2#
9	A_CK	10	A_CK#
11	A_Y3	12	A_Y3#
13	GND	14	GND
15	B_Y0	16	B_Y0#
17	B_Y1	18	B_Y1#
19	B_Y2	20	B_Y2#
21	B_CK	22	B_CK#
23	B_Y3	24	B_Y3#
25	GND	26	GND
27	VCC_LCD	28	VCC_LCD
29	VCC_LCD	30	VCC_LCD

Table 4-18: LVDS Connector Pinouts

4.2.15 Parallel Port Connector

- CN Label:** LPT1
- CN Type:** 25-pin box header
- CN Location:** See **Figure 4-15**
- CN Pinouts:** See **Table 4-19**

The parallel port connector is usually connected to a printer or other parallel device with a 26-pin flat-cable connector.

WSB-9452 PICMG 1.0 CPU Card

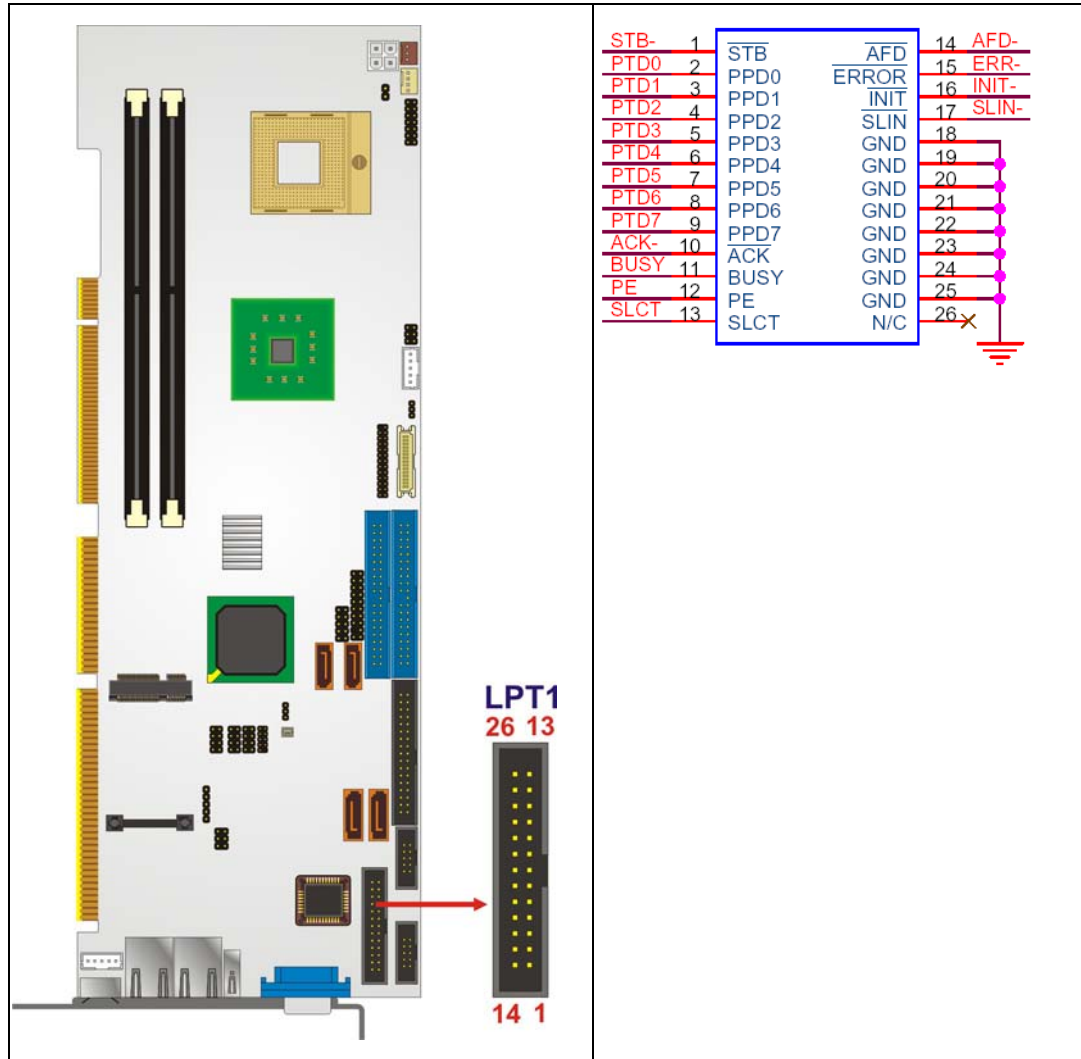

Figure 4-15: Parallel Port Connector Location

PIN	DESCRIPTION	PIN	DESCRIPTION
1	STROBE#	14	AUTO FORM FEED #
2	DATA0	15	ERROR#
3	DATA1	16	INITIALIZE#
4	DATA2	17	PRINTER SELECT LN#
5	DATA3	18	GND
6	DATA4	19	GND
7	DATA5	20	GND
8	DATA6	21	GND

9	DATA7	22	GND
10	ACKNOWLEDGE#	23	GND
11	BUSY	24	GND
12	PAPER EMPTY	25	GND
13	PRINTER SELECT		

Table 4-19: Parallel Port Connector Pinouts

4.2.16 PCI Express Mini Card Connector

- CN Label:** CN1
- CN Type:** 52-pin PCI-E Mini Card slot
- CN Location:** See **Figure 4-16**
- CN Pinouts:** See **Table 4-20**

The CPU card is equipped with a PCI-E Mini Card connector to support the latest PCI-E extension cards such as wireless LAN card or other compatible devices.

WSB-9452 PICMG 1.0 CPU Card

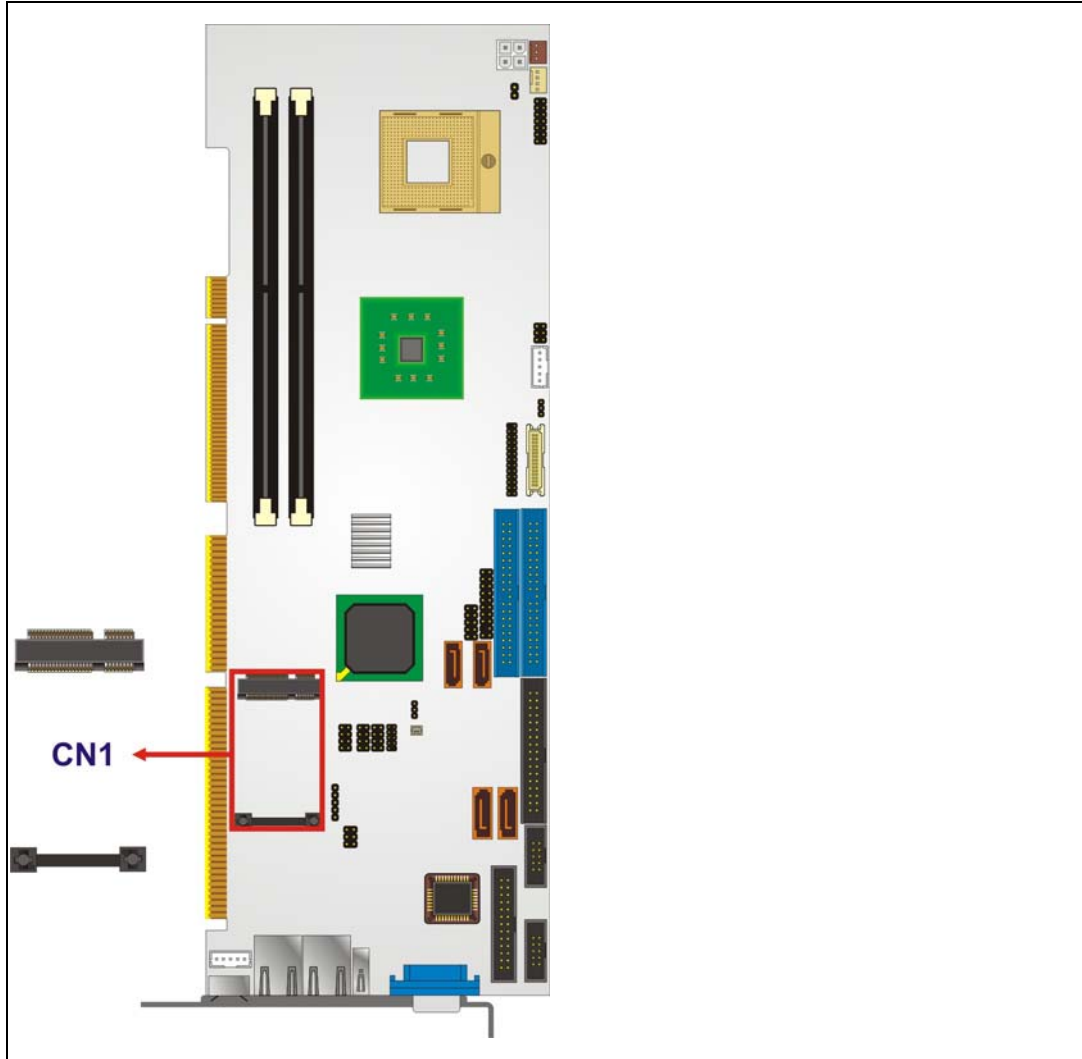

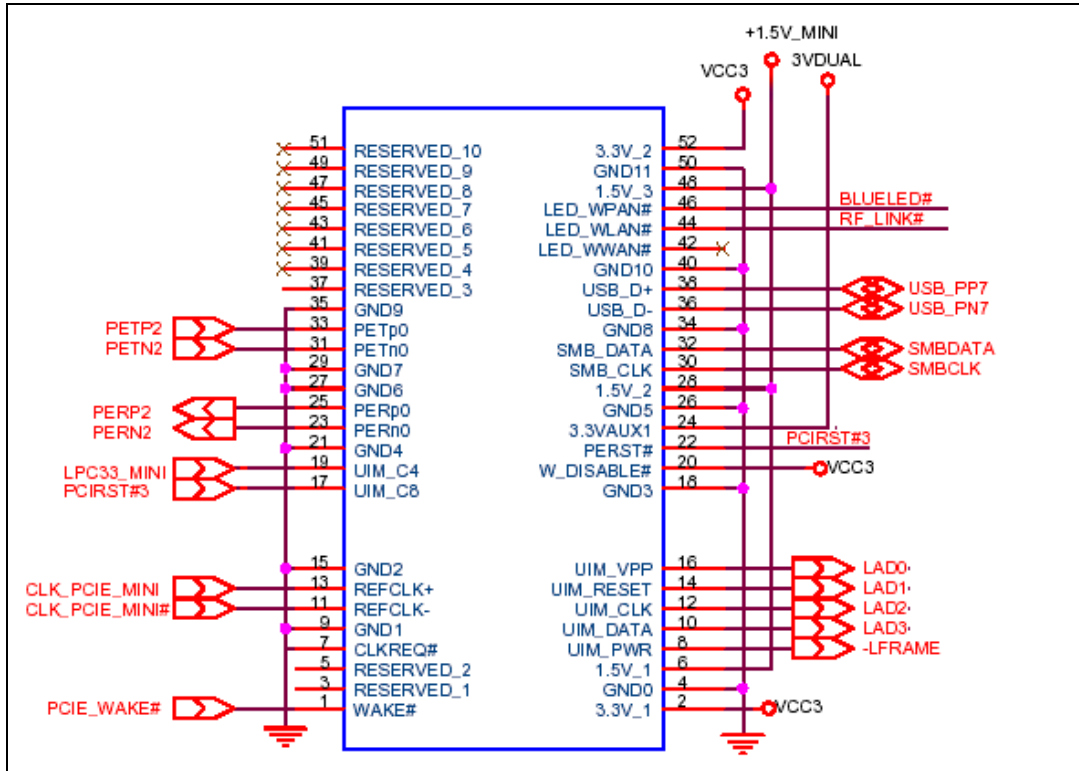

Figure 4-16: PCI Express Mini Card Connector Location

PIN	DESCRIPTION	PIN	DESCRIPTION
1	PCIE_WAKE#	2	VCC3
3	N/C	4	GND
5	N/C	6	1.5V
7	CLKREQ#	8	LFRAME#
9	GND	10	LAD3
11	CLK-	12	LAD2
13	CLK+	14	LAD1
15	GND	16	LAD0
17	PCIRST#	18	GND
19	LPC	20	VCC3
21	GND	22	PCIRST#
23	PERN2	24	3VDual
25	PERP2	26	GND
27	GND	28	1.5V

WSB-9452 PICMG 1.0 CPU Card

29	GND	30	SMBCLK
31	PETN2	32	SMBDATA
33	PETP2	34	GND
35	GND	36	USB D-
37	N/C	38	USB D+
39	N/C	40	GND
41	N/C	42	N/C
43	N/C	44	RF_LINK#
45	N/C	46	BLUELED#
47	N/C	48	1.5V
49	N/C	50	GND
51	N/C	52	VCC3

Table 4-20: PCI Express Mini Card Connector Pinouts

4.2.17 RS-232 Serial Port Connectors

CN Label:	COM1, COM2
CN Type:	10-pin box header
CN Location:	See Figure 4-17
CN Pinouts:	See Table 4-21

The WSB-9452 CPU card has two internal high-speed UART connectors accessed through a 10-pin cable connector.

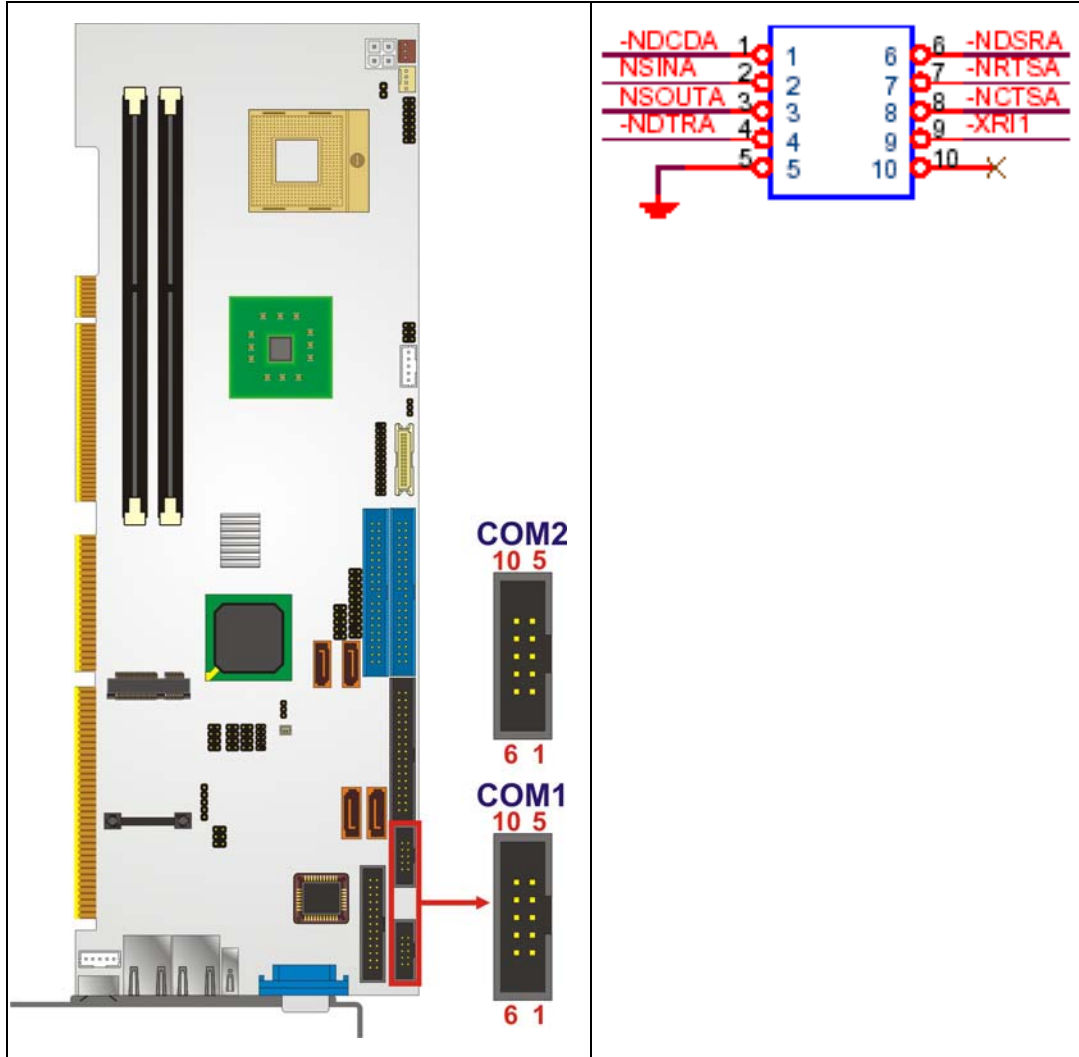

Figure 4-17: RS-232 Serial Port Connector Location

PIN	DESCRIPTION	PIN	DESCRIPTION
1	DATA CARRIER DETECT (DCD1)	6	DATA SET READY (DSR1)
2	RECEIVE DATA (RXD1)	7	REQUEST TO SEND (RTS1)
3	TRANSMIT DATA (TXD1)	8	CLEAR TO SEND (CTS1)
4	DATA TERMINAL READY (DTR1)	9	RING INDICATOR (RI 1)
5	GND (GND1)	10	N/C

Table 4-21: RS-232 Serial Port Connector Pinouts

4.2.18 SATA Drive Connectors

CN Label: SATA1, SATA2, SATA3, SATA4

CN Type: 7-pin SATA drive connector

CN Location: See **Figure 4-18**

CN Pinouts: See **Table 4-22**

The SATA drive ports are connect to SATA HDDs with SATA signal cables. The SATA II connectors provide connectivity with a maximum data transfer rate of 300 MB/s.

The SATA3 and SATA4 connectors are found only on the WSB-9452S and WSB-9452SDVI.

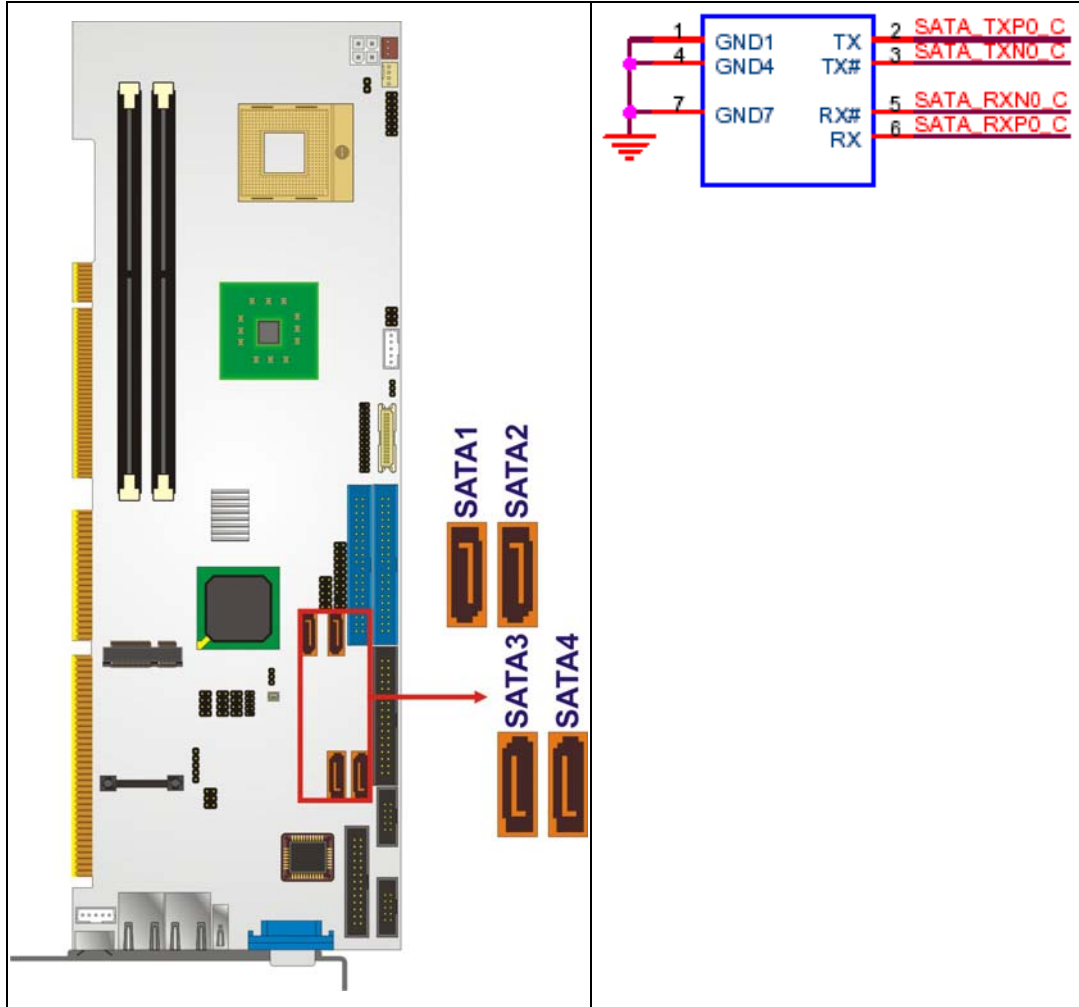

Figure 4-18: SATA Connectors Location

PIN	DESCRIPTION	PIN	DESCRIPTION
1	GND	5	RX-
2	TX+	6	RX+
3	TX-	7	GND
4	GND	8	N/C

Table 4-22: SATA Connectors Pinouts

**CAUTION:**

Your SATA hard drives may come with both a 4P power connector and a SATA power interface. Attach either the 4P connector or the included SATA power cable to your SATA hard drives. **DO NOT** attach both the power connectors to your SATA hard drives at the same time! Doing so will cause damage.

**NOTE:**

1. SATA is supported by:
 - Windows® 2000 SP4
 - Windows® XP SP1
 - Windows® 2003, or later versions
 2. Older OSes, such as Windows® 98SE or Me, do not support the SATA interface.
-

4.2.19 Trusted Platform Module Connector

CN Label:	TPM1
CN Type:	20-pin header
CN Location:	See Figure 4-19
CN Pinouts:	See Table 4-23

The TPM connector is a trusted platform module connector used to secure the system on bootup.

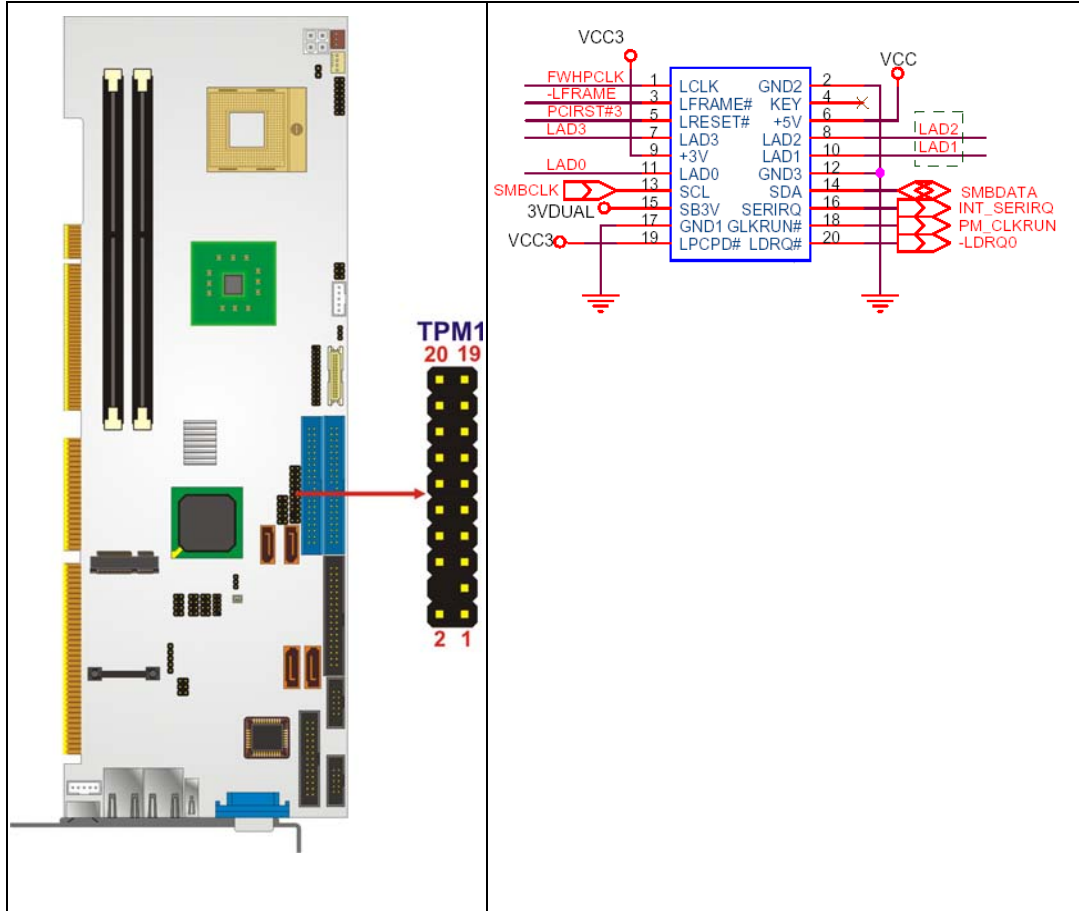

Figure 4-19: TPM Connector Location

PIN NO.	DESCRIPTION	PIN NO.	DESCRIPTION
1	FWHPCLK	2	GND
3	LFRAME#	4	KEY
5	PCIRST#	6	VCC
7	LAD3	8	LAD2
9	VCC3	10	LAD1
11	LAD0	12	GND

WSB-9452 PICMG 1.0 CPU Card

13	SMBCLK	14	SMBDATA
15	3VDUAL	16	SERIRQ
17	GND	18	CLKRUN#
19	LPCPD#	20	LDRQ#

Table 4-23: TPM Connector Pinouts

4.2.20 TV Out Connector

- CN Label:** TV1
- CN Type:** 6-pin header
- CN Location:** See **Figure 4-20**
- CN Pinouts:** See **Table 4-24**

The 2x3 pin TV out connector connects to a TV.

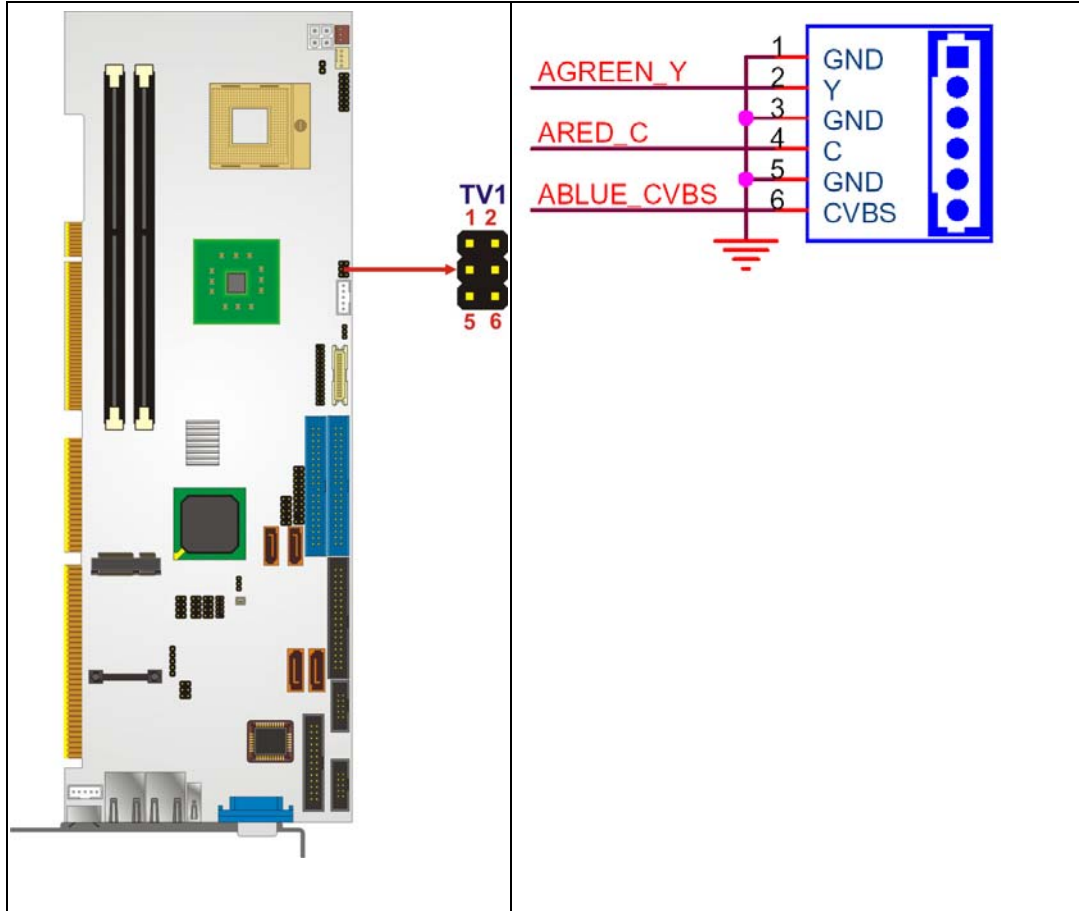

Figure 4-20: TV Out Connector Location

PIN NO.	DESCRIPTION	PIN NO.	DESCRIPTION
1	GND	2	AGREEN_Y
3	GND	4	ARED_C
RCA Connector (only video signal)			
5	GND	6	ABLUE_CVBS

Table 4-24: TV Out Connector Pinouts

WSB-9452 PICMG 1.0 CPU Card

4.2.21 USB Connectors

CN Label: USB01, USB23, USB45

CN Type: 8-pin header

CN Location: See Figure 4-21

CN Pinouts: See Table 4-25

Three 2x4 pin connectors provide connectivity to six USB 2.0 ports. An additional USB port is found on the rear panel. The USB ports are used for I/O bus expansion.

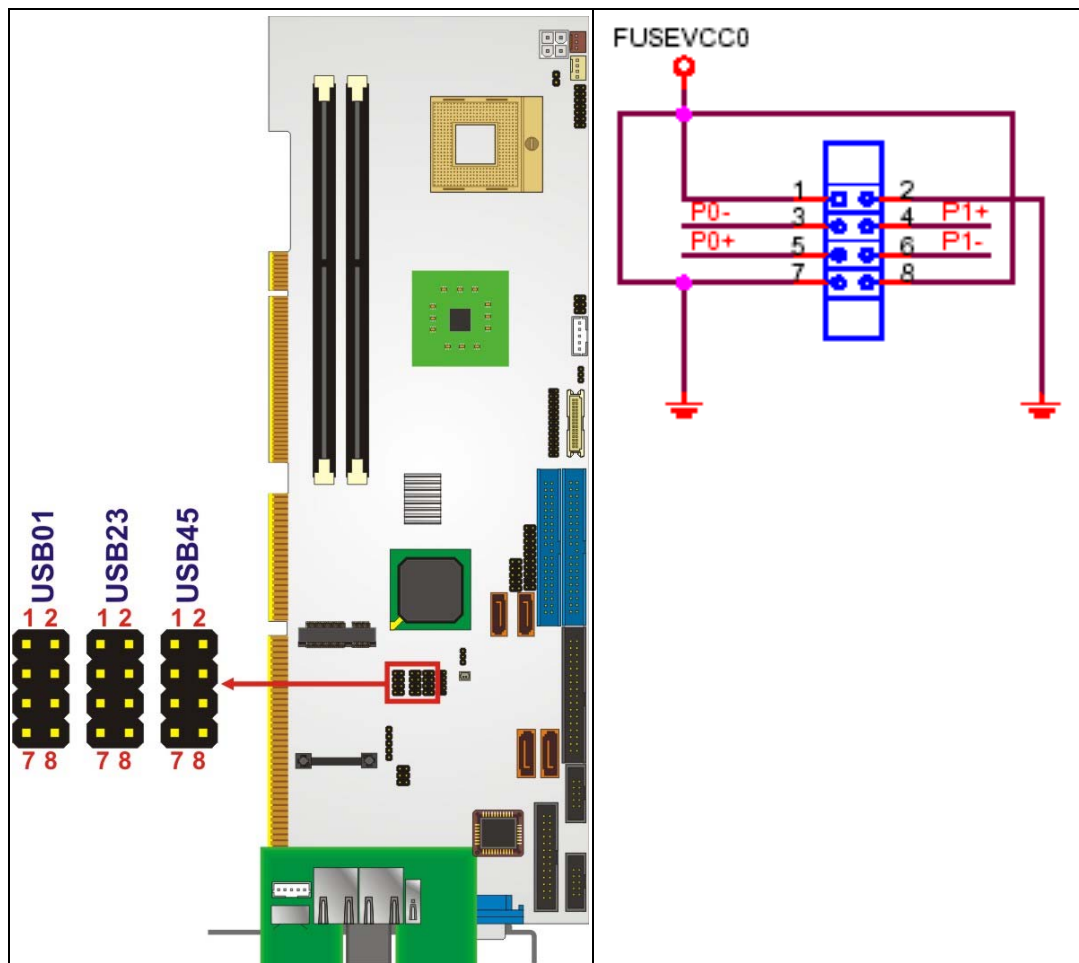

Figure 4-21: USB Port Connector Location

PIN	DESCRIPTION	PIN	DESCRIPTION
1	VCC	2	GND
3	DATA-	4	DATA+
5	DATA+	6	DATA-
7	GND	8	VCC

Table 4-25: USB Port Connector Pinouts

4.3 External Peripheral Interface Connectors

Figure 4-22 shows the WSB-9452 CPU card rear panel. The peripheral connectors on the back panel can be connected to devices externally when the CPU card is installed in a chassis. The peripheral connectors on the rear panel are:

- 1 x PS/2 keyboard connector
- 1 x USB connectors
- 2 x RJ-45 GbE connectors
- 1 x VGA connector

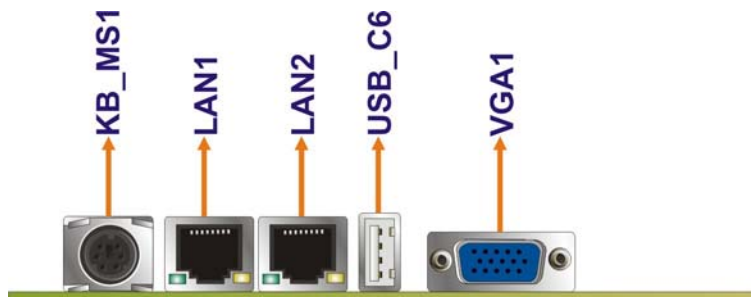

Figure 4-22: External Peripheral Interface Connector Panel

4.3.1 LAN Connectors

- CN Label:** LAN1 and LAN2
- CN Type:** RJ-45
- CN Location:** See **Figure 4-22** (labeled number 2)
- CN Pinouts:** See **Table 4-26**

The WSB-9452 is equipped with two built-in GbE Ethernet controllers. The controllers can connect to the LAN through two RJ-45 LAN connectors. There are two LEDs on the connector indicating the status of LAN. The pin assignments are listed in the following table:

PIN NO.	DESCRIPTION	PIN NO.	DESCRIPTION
1	MDIA3-	MDIA1+	MDIA1+
2	MDIA3+	MDIA2+-	MDIA2+-
3	MDIA2-	MDIA0-	MDIA0-
4	MDIA1-	MDIA0+	MDIA0+

Table 4-26: LAN Pinouts

PIN	DESCRIPTION	PIN	DESCRIPTION
1	MDIA3-	5	MDIA1+
2	MDIA3+	6	MDIA2+-
3.	MDIA2-	7	MDIA0-
4.	MDIA1-	8	MDIA0+

Table 4-27: Ethernet Connector Pinouts

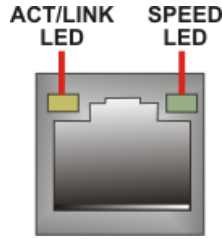

Figure 4-23: RJ-45 Ethernet Connector

The RJ-45 Ethernet connector has two status LEDs, one green / orange and one yellow. The green / orange LED indicates the speed and the yellow LED indicates activity or is linked on the port. See **Table 4-27**.

SPEED LED		ACT/LINK LED	
STATUS	DESCRIPTION	STATUS	DESCRIPTION
GREEN	100Mbps connection	YELLOW	Linked
ORANGE	1Gbps connection	BLINKING	Data Activity

Table 4-27: RJ-45 Ethernet Connector LEDs

4.3.2 Mini-DIN 6 PS/2 Connector

- CN Label:** KB_MS1
- CN Type:** Mini-DIN 6 PS/2
- CN Location:** See **Figure 4-22** (labeled number 1)
- CN Pinouts:** See **Table 4-28**

The WSB-9452CPU card has a mini-DIN 6 PS/2 connector on the mounting bracket for easy connection to a PS/2 keyboard or PS/2 mouse. The card comes with a cable to convert the mini-DIN 6 PS/2 into two mini-DIN 6 PS/2 connectors for keyboard and mouse connection.

WSB-9452 PICMG 1.0 CPU Card

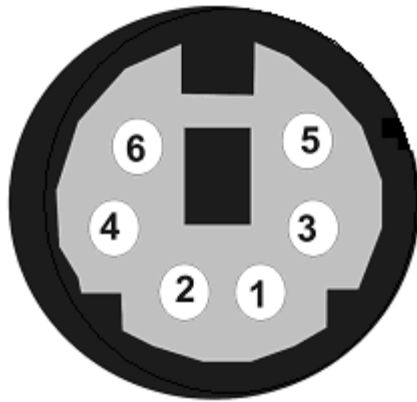

Figure 4-24: Mini-DIN 6 PS/2 Connector

PIN NO.	DESCRIPTION
1	Keyboard Data
2	Mouse Data
3	GND
4	VCC
5	Keyboard Clock
6	Mouse Clock

Table 4-28: Mini-DIN 6 PS/2 Connector

4.3.3 USB Connector

- CN Label:** USB_C6
- CN Type:** USB port
- CN Location:** See Figure 4-22 (labeled number 3)
- CN Pinouts:** See Table 4-29

The WSB-9452 has a one rear panel USB port. This port connects to both USB 2.0 and USB 1.1 devices.

PIN NO.	DESCRIPTION
1	VCC
2	DATA-
3	DATA+
4	GROUND

Table 4-29: USB Port Pinouts

4.3.4 VGA connector

CN Label: VGA1

CN Type: HD-D-sub 15 female connector

CN Location: See **Figure 4-22** (labeled number 4)

CN Pinouts: See **Table 4-30**

A 15-pin VGA connector connects to standard displays.

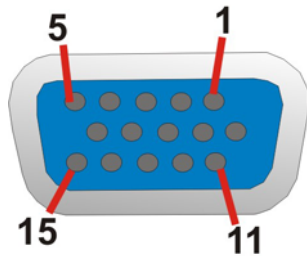
Figure 4-25: VGA Connector

PIN NO.	DESCRIPTION	PIN NO.	DESCRIPTION
1	RED	2	GREEN
3	BLUE	4	NC
5	GND	6	GND
7	GND	8	GND
9	VCC	10	GND
11	NC	12	DDCDAT

WSB-9452 PICMG 1.0 CPU Card

13	HSYNC	14	VSYNC
15	DDCCLK		

Table 4-30: VGA Connector Pinouts



Chapter

5

Installation and Configuration

WSB-9452 PICMG 1.0 CPU Card

5.1 Anti-static Precautions

Electrostatic discharge (ESD) can cause serious damage to electronic components, including the WSB-9452. (Dry climates are especially susceptible to ESD.) It is therefore critical that whenever the WSB-9452 (or any other electrical component) is handled, the following anti-static precautions are strictly adhered to.

- **Wear an anti-static wrist band:** Wearing a simple anti-static wrist band can help to prevent ESD from damaging the board.
- **Self-grounding:** Before handling the board, touch any grounded conducting material. During the time the board is handled, frequently touch any conducting materials that are connected to the ground.

5.2 Installation Considerations



NOTE:

The following installation notices and installation considerations should be read and understood before the CPU card is installed. All installation notices pertaining to the installation of the CPU card should be strictly adhered to. Failing to adhere to these precautions may lead to severe damage of the CPU card and injury to the person installing the CPU card.

5.2.1 Installation Notices

Before and during the installation of the WSB-9452 CPU card, please **do** the following:

- Read the user manual
 - The user manual provides a complete description of the WSB-9452 CPU card, installation instructions and configuration options.

- Wear an electrostatic discharge cuff (ESD)
 - Electronic components are easily damaged by ESD. Wearing an ESD cuff will remove ESD from your body and help to prevent ESD damage to the CPU card.
- Place the CPU Card on an antistatic pad
 - When you are installing or configuring the CPU Card, place it on an antistatic pad. This will help to prevent potential ESD damage.
- Turn off all power to the WSB-9452 CPU card
 - When working with the CPU card, make sure that it is disconnected from all power supplies and that no electricity is being fed into the system.

Before and during the installation of the WSB-9452 CPU card **DO NOT:**

- remove any of the stickers on the PCB board. These stickers are required for warranty validation.
- use the product before you have verified that all cables and power connectors are properly connected.
- allow screws to come in contact with the PCB circuit, connector pins, or its components.

5.3 Unpacking



NOTE:

If any of the items listed below are missing when you unpack the WSB-9452 CPU card, do not proceed with the installation and contact the reseller or vendor you purchased the CPU card from.

5.3.1 Unpacking Precautions

Before you install the WSB-9452 CPU card, you must unpack the CPU card. Some components on WSB-9452 are very sensitive to static electricity and can be damaged by a sudden rush of power. To protect it from being damage, follow these precautions:

WSB-9452 PICMG 1.0 CPU Card

- Ground yourself to remove any static charge before touching your WSB-9452 . You can do so by wearing a grounded wrist strap at all times or by frequently touching any conducting materials that is connected to the ground.
- Handle your WSB-9452 by its edges. Do not touch the IC chips, leads or circuitry if not necessary.

Do not place a PCB on top of an anti-static bag. Only the inside of the bag is safe from static discharge.

5.3.2 Checklist

When you unpack the WSB-9452, please make sure that your package contains the following items.

- 1 x WSB-9452 single board computer
- 1 x Mini jumper pack
- 1 x ATA 66/100 flat cable
- 1 x Dual RS-232 cable
- 2 x SATA cables
- 1 x SATA power cable
- 1 x Keyboard/ PS2 mouse Y cable
- 1 x USB cable
- 1 x Utility CD
- 1 x QIG (quick installation guide)

If one or more of these items are missing, please contact the reseller or vendor you purchased the WSB-9452 CPU card from and do not proceed any further with the installation.

5.4 WSB-9452 CPU Card Installation



WARNING:

Never run the CPU card without an appropriate heatsink and cooler that can be ordered from IEI Technology or purchased separately.

Be sure to use the CPU 12V power connector (CPU12V1) for the CPU power.



WARNING:

Please note that the installation instructions described in this manual must be carefully followed in order to avoid damage to the CPU card components and injury to you.



WARNING:

When installing electronic components onto the CPU card always follow the previously outlined anti-static precautions in order to prevent ESD damage to your board and other electronic components like the CPU and DIMM modules

The following components must be installed onto the CPU card or connected to the CPU card during the installation process.

- CPU
- CPU cooling kit

WSB-9452 PICMG 1.0 CPU Card

- DDR2 memory modules
- Peripheral devices

5.4.1 Socket 478 CPU Installation



WARNING:

CPUs are expensive and sensitive components. When installing the CPU please be careful not to damage it in anyway. Make sure the CPU is installed properly and ensure that a heat sink and CPU cooling fan are properly installed before the WSB-9452 board is run.

If a heat sink and cooling fan are not properly installed both the CPU and the board may be damaged.

To install Socket 478-pin CPU onto the WSB-9452 board, follow the steps below:



WARNING:

When handling the CPU, only hold it on the sides. DO NOT touch the pins at the bottom of the CPU.

- Step 1:** Is the CPU retention screw in an unlocked position? When shipped, the retention screw of the CPU socket should be in the unlocked position. If it is not in the unlocked position, use a screwdriver to position it in an unlocked position. (See **Figure 5-1**)

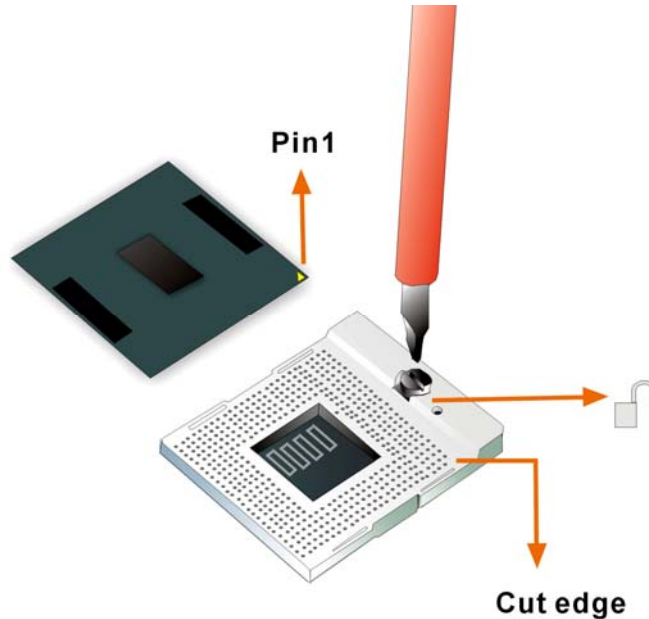

Figure 5-1: Make sure the CPU socket retention screw is unlocked

- Step 2: Inspect the CPU socket.** Make sure there are no bent pins and make sure the socket contacts are free of foreign material. If any debris is found, remove it with compressed air.
- Step 3: Correctly position the CPU.** Make sure the pin 1 mark matches the cut edge on the CPU socket. Carefully place the CPU on top of the socket. When properly placed, the CPU should be easily inserted into the socket.
- Step 4: Insert the CPU.** To insert the CPU into the socket, hold the CPU by its edges and follow the instructions below:
- Step 5:** Correctly orientate the CPU with the IHS (Integrated Heat Sink) side facing upward.
- Step 6:** Locate the pin 1 mark on the CPU.
- Step 7:** Gently insert the CPU into the socket.
- Step 8:** Rotate the retention screw into the locked position. (See **Figure 5-2**)

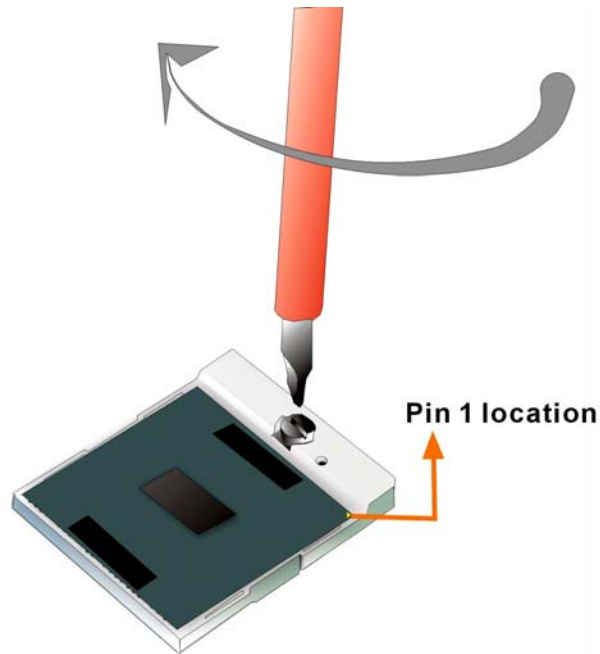

Figure 5-2: Lock the CPU Socket Retention Screw

5.4.2 Cooling Kit (CF-479B-RS) Installation



Figure 5-3: IEI CF-479B-RS Cooling Kit

IEI provides a cooling kit designed for socket 478 CPUs. (See **Figure 5-3**) The cooling kit is comprised of a CPU heat sink and a cooling fan.

NOTE:

The CF-479B-RS heat sink comes with a sprayed layer of thermal paste. Make sure the paste is not accidentally wiped during the unpacking or installation of the heat sink. Thermal paste between the CPU and the heat sink is important for optimum heat dissipation.

To install the CF-479B-RS cooling kit, please follow the steps below.

Step 1: Install the support bracket. Remove the tape from the support bracket. From the solder side of the board, align the support bracket to the holes on board and stick in place.

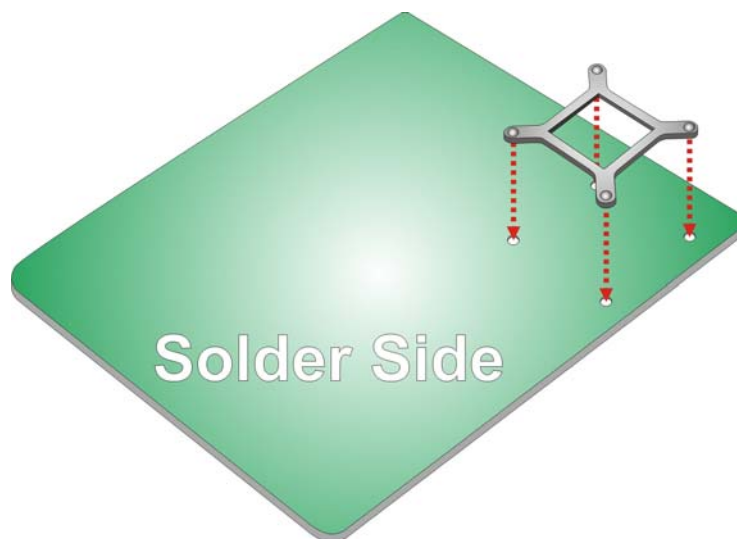

Figure 5-4: Install Support Bracket

Step 2: Properly orient the cooling kit. The CPU fan cable must not interfere with the fan or other moving parts. Make sure the cable can be routed away from the moving parts.

Step 3: Properly align the cooling kit. Line up the four screws with the screw holes on the support bracket below the board (**Figure 5-5**).

WSB-9452 PICMG 1.0 CPU Card

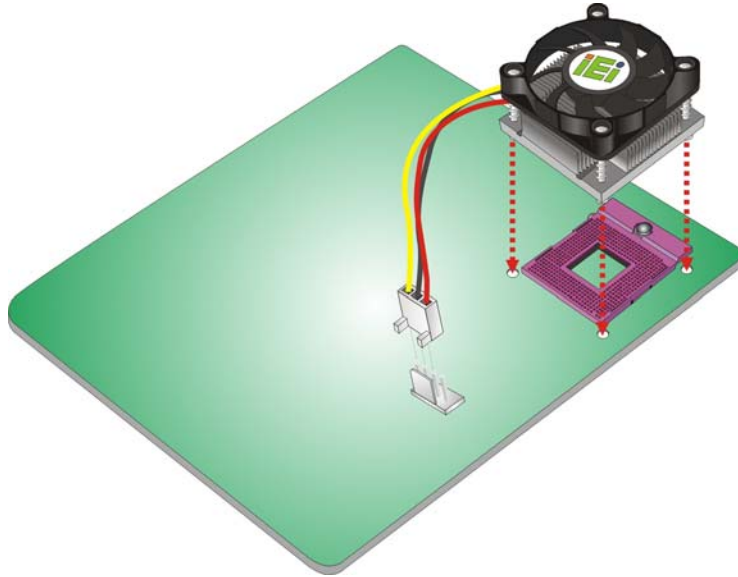

Figure 5-5: Align the Cooling Kit

- Step 4:** Place the cooling kit onto the CPU. Push down the fan with some pressure to secure the cooling kit with the support bracket. See **Figure 5-6**.
- Step 5:** Tighten the screws. Use a screwdriver to tighten the four screws. In a diagonal pattern, tighten each screw a few turns then move to the next one, until they are all secured. Do not overtighten the screws. See **Figure 5-6**.
- Step 6:** Connect the fan cable. Connect the cooling kit fan cable to the fan connector on the board. Carefully route the cable away from heat generating chips and fan blades.

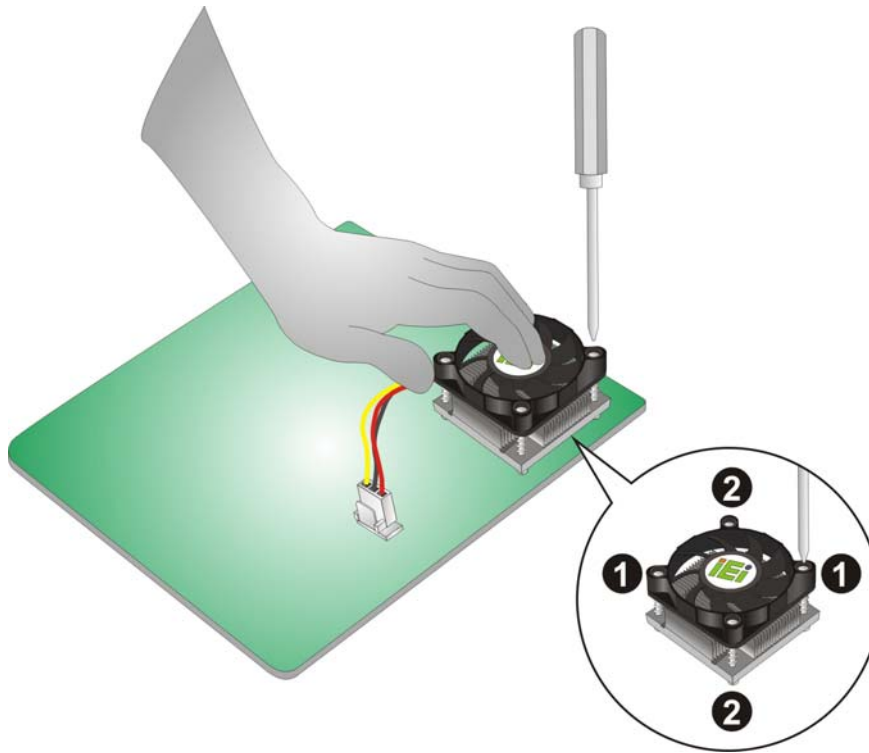

Figure 5-6: Secure the Cooling Kit

5.4.3 DIMM Module Installation

5.4.3.1 Purchasing the Memory Module



WARNING:

When purchasing the DIMM modules, make sure the modules are compatible with the DIMM slot specified in **Section 2.6 Memory Support**.

**WARNING:**

The board supports DDR2 DIMM modules only. DDR1 and DDR2 are not compatible. If a DDR1 DIMM module is installed, the system may be damaged and become inaccessible. Please only use DDR2 DIMM modules.

When you purchase your DIMM modules, the following considerations should be taken into account:

- Each DIMM socket can support DIMM modules with a maximum size of 2GB
- Only use DDR2 memory chips in the DIMM slots
- It is recommended that you use memory modules of identical brand, size, chips, and speed.
- DIMMs must use the same density memory chips
- Both DIMMs must use the same DRAM bus width
- Both DIMMs must be either single-sided or dual-sided

5.4.3.2 DIMM Module Installation

The WSB-9452 CPU card has two 240-pin DDR2 SDRAM DIMM sockets. To install the DIMM modules, follow the instructions below.

Step 1: Make sure the two handles of the DIMM socket are in the "open" position, leaning outward (**Figure 5-7**).

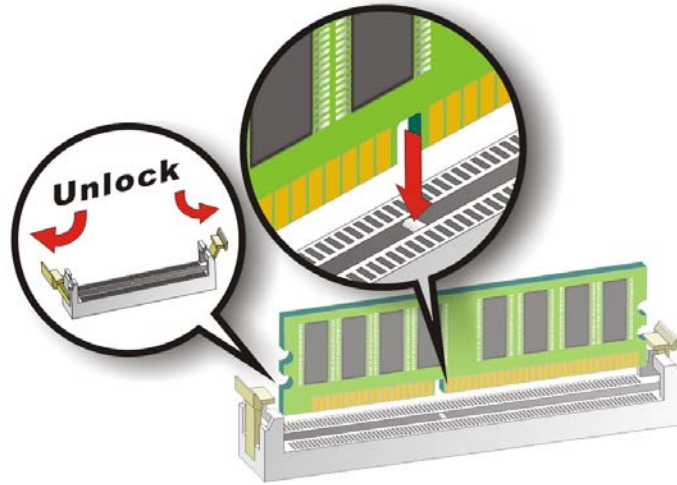

Figure 5-7: Installing the DIMM Module

WSB-9452 PICMG 1.0 CPU Card

Step 2: Slowly slide the DIMM module along the plastic guides on both ends of the socket. Press the DIMM module down into the socket until it clicks into position and the two handles have automatically locked the memory module into place.

Step 3: To remove the memory module, push both handles outward, and the memory module is ejected by the mechanism in the socket.

5.4.4 Peripheral Device Connection

Cables provided by IEI that connect peripheral devices to the CPU Card are listed in **Table 5-1**. Cables not included in the kit must be separately purchased.

Quantity	Type
1	ATA 66/100 flat cable
2	SATA cables
1	SATA power cable
1	Keyboard/ PS2 mouse Y cable
1	RS-232 cable
1	USB cable

Table 5-1: IEI Provided Cables

5.4.4.1 IDE Disk Drive Connectors (IDE1, IDE2)

The cable used to connect the motherboard to the IDE device is a standard 40-pin ATA/100 flat cable. To connect an IDE device to the motherboard, follow the instructions below.

- Step 1:** Find the IDE flat cable in the kit that came with the motherboard.
- Step 2:** Connect one end of the cable to the IDE connector on the motherboard. A keyed pin on the IDE connector prevents it from being connected incorrectly.
- Step 3:** Locate the red wire on the other side of the cable that corresponds to the pin 1 connector.
- Step 4:** Connect the other side of the cable to the IDE device making sure that the pin 1 cable corresponds to pin 1 on the connector.

WSB-9452 PICMG 1.0 CPU Card

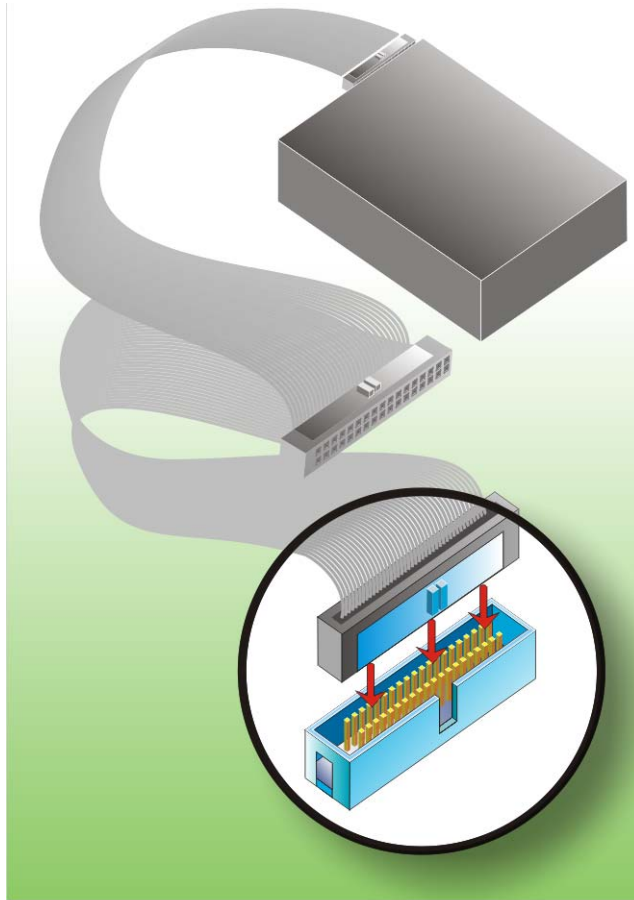

Figure 5-8: Connection of IDE Connector



NOTE:

When two IDE disk drives are connected together, back-end jumpers on the drives must be used to configure one drive as a master and the other as a slave.

5.4.4.2 Floppy Drive Connector (FDD1)

This connector provides access to an externally mounted 3.5" floppy drive. To connect the CPU Card to a FDD, follow the instructions below.

Step 1: Insert one side of the cable into the FDC making sure that the red wire on the cable corresponds to pin 1 on the connector.

Step 2: Attach the connector on the other side of the cable to the floppy drive(s). You can only use one connector in the set. The connection sequence determines which of the two connected floppy drives is drive A: and which is drive B.

5.4.5 SATA Drive Connection

The CPU card has on-board SATA drive connectors. Refer to **Table 1-1** for model variations supporting two or four SATA II connectors. To connect the SATA drives to the connectors, follow the steps below.

Step 1: Locate the SATA drive connector on the board.

Step 2: Press the clip on the connector at the end of the SATA cable and insert the cable connector into the on-board SATA drive connector (**Figure 5-9**).

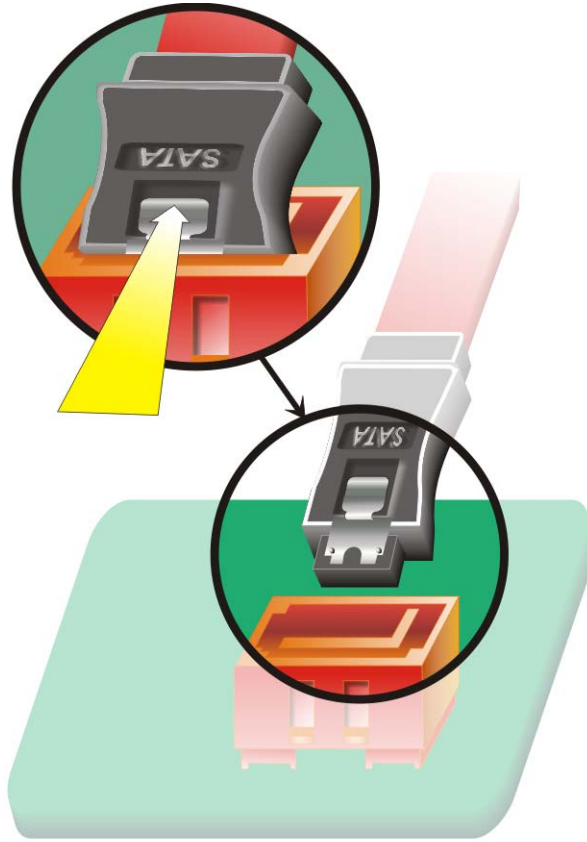

Figure 5-9: SATA Drive Cable Connection

Step 3: Connect the connector on the other end of the cable to the connector at the back of the SATA drive (**Figure 5-10**).

Step 4: Connect the SATA power connector to the back of the SATA drive (**Figure 5-10**).

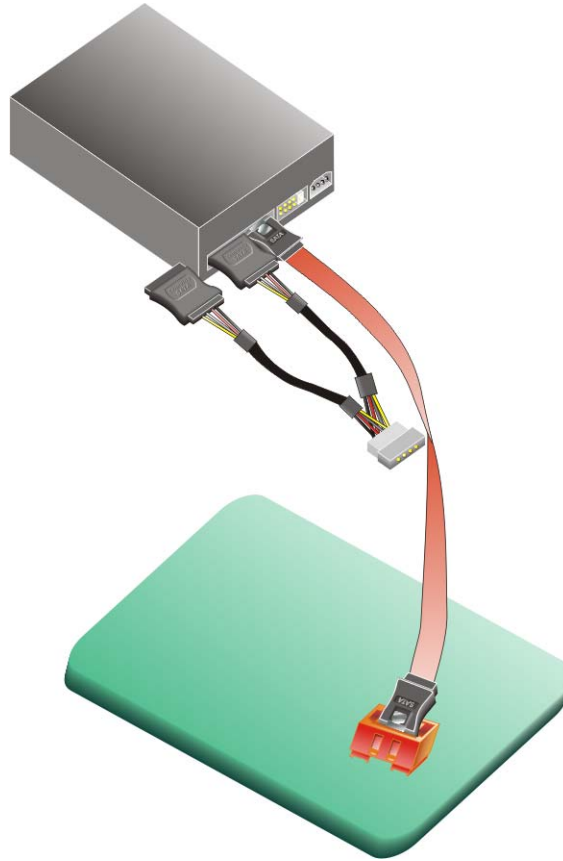

Figure 5-10: SATA Drive Connection

5.4.6 Installing the RS-232 Cable

A dual RS-232 cable consisting of two cables attached to two D-sub 9 male connectors that are mounted onto a bracket can be connected to the COM1 and COM2 RS-232 connectors. To install an RS-232 cable, follow the steps below.

Step 1: Locate the two RS-232 serial port connectors.

Step 2: Insert the two small connectors on the cables into the serial port box headers on the CPU card (**Figure 5-11**).

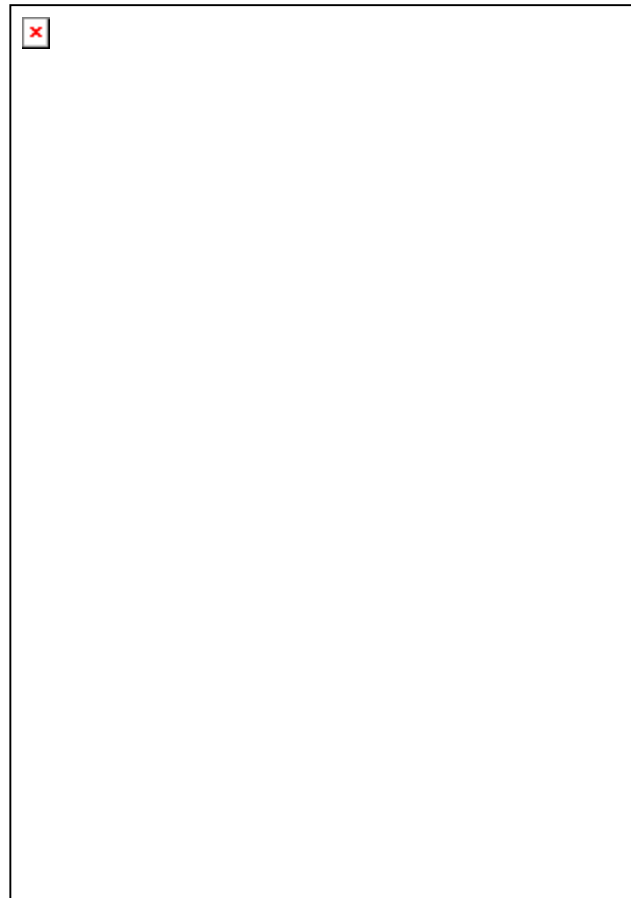

Figure 5-11: Dual RS-232 Cable Installation

Step 3: Secure the bracket supporting the two D-sub 9 male connectors to the chassis. To do this, refer to the chassis manual.

5.4.7 USB 2.0 Cable Connection

The CPU card is shipped with a dual USB cable. The dual USB cable consists of two connectors attached to two independent cables. Each cable is then attached to a USB port connector that is mounted on a bracket. To install the USB cable, follow the steps below.

Step 1: Install a USB module supporting two USB ports to the chassis. Secure the USB module bracket following the instructions in the documentation that came with the USB module and the chassis.

Step 2: Insert the two 4-pin connectors from the module into the USB pin headers on the CPU card. (Figure 5-12)

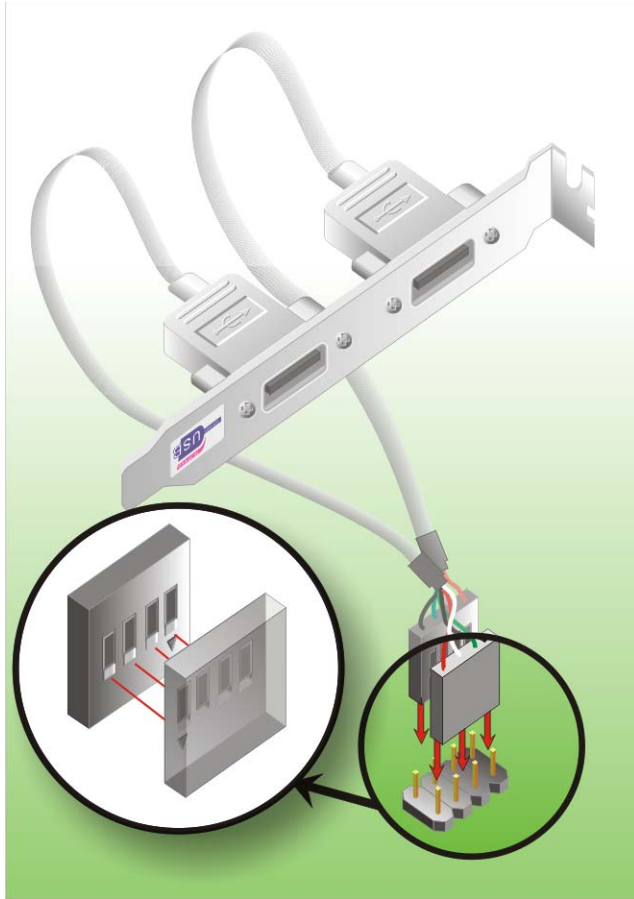

Figure 5-12: USB Cable Installation

5.5 On-board Jumpers



NOTE:

A jumper is a metal bridge that is used to close an electrical circuit. It consists of two metal pins and a small metal clip (often protected by a plastic cover) that slides over the pins to connect them. To CLOSE/SHORT a jumper means connecting the pins of the jumper with the plastic clip and to OPEN a jumper means removing the plastic clip from a jumper.

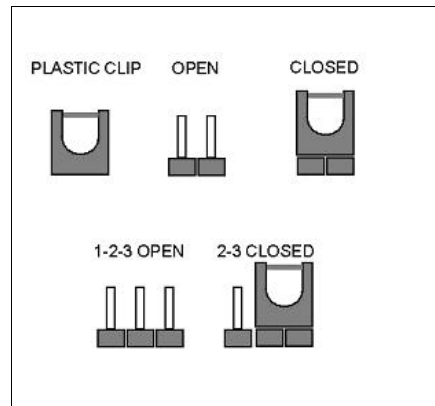

Figure 5-13 Jumper

The CPU card two on-board jumpers. The jumpers are described in **Table 5-2**.

Label	Connector	Type
J_CMOS1	CMOS state setting	3-pin header
J_LVDS1	L CD Voltage select	3-pin header
JAUTO1	AT/ATX mode select	2-pin header
JLAN_PWR1	LAN power select	6-pin header

Table 5-2: On-board Jumpers

5.5.1 AT Power Select Jumper Settings

- Jumper Label:** JAUTO1
- Jumper Type:** 2-pin header
- Jumper Settings:** See **Table 5-3**
- Jumper Location:** See **Figure 5-14**

The AT Power Select jumper specifies the systems power mode as AT or ATX. AT Power Select jumper settings are shown in **Table 5-3**.

AT Power Select	Description	
Short	Use AT power	
Open	Use ATX power	Default

Table 5-3: AT Power Select Jumper Settings

The location of the AT Power Select jumper is shown in **Figure 5-14** below.

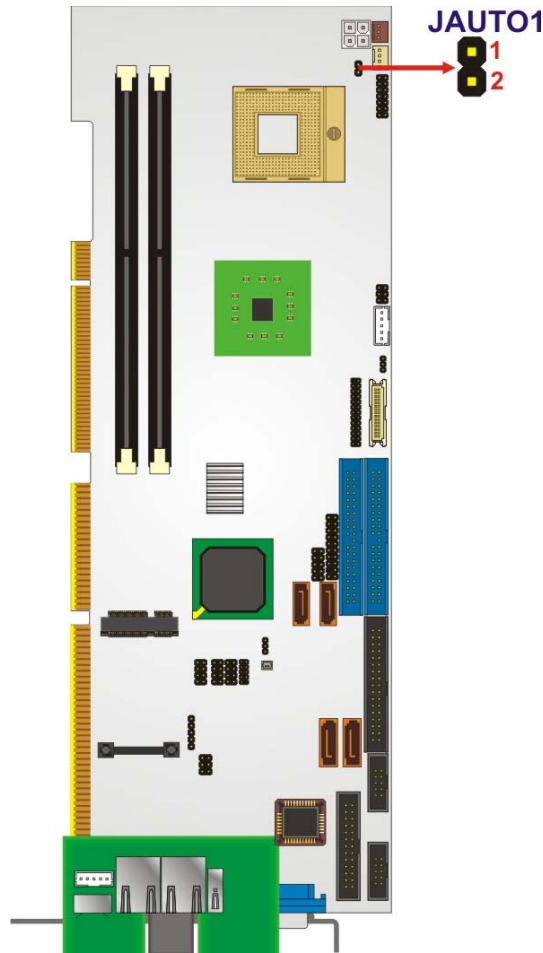

Figure 5-14: AT Power Select Jumper Location

5.5.2 Clear CMOS Jumper

WSB-9452 PICMG 1.0 CPU Card

Jumper Label:	J_CMOS1
Jumper Type:	3-pin header
Jumper Settings:	See Table 5-4
Jumper Location:	See Figure 5-15

If the CPU card fails to boot due to improper BIOS settings, use this jumper to clear the CMOS data and reset the system BIOS information. To do this, use the jumper cap to close pins 2 and 3 for a few seconds then reinstall the jumper clip back to pins 1 and 2.

If the “CMOS Settings Wrong” message is displayed during the boot up process, the fault may be corrected by pressing the F1 to enter the CMOS Setup menu. Do one of the following:

- Enter the correct CMOS setting
- Load Optimal Defaults
- Load Failsafe Defaults.

After having done one of the above, save the changes and exit the CMOS Setup menu.

J_CMOS1	DESCRIPTION
Short 1-2 (Default)	Normal Operation
Short 2-3	Clear CMOS Setup

Table 5-4: Clear CMOS Jumper Settings

The location of the clear CMOS jumper is shown in **Figure 5-15** below.

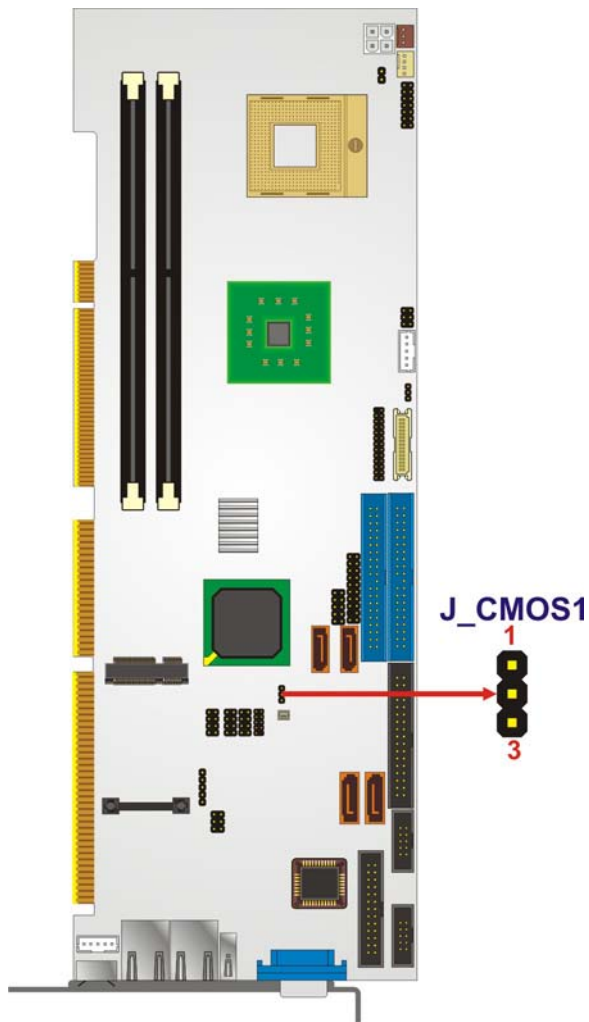

Figure 5-15: Clear CMOS Jumper

5.5.3 LVDS LCD Voltage Selection



WARNING:

Making the wrong setting on this jumper may cause irreparable damage to both the motherboard and the LCD screen connected to the on-board connector.

WSB-9452 PICMG 1.0 CPU Card

- Jumper Label:** J_LVDS1
- Jumper Type:** 3-pin header
- Jumper Settings:** See **Table 5-5**
- Jumper Location:** See **Figure 5-16**

This jumper allows the user to set the voltage for the LCD panel. Before setting this jumper please refer to the LCD panel user guide to determine the required voltage. After the required voltage is known, make the necessary jumper setting in accordance with the settings shown in **Table 5-5**.

J_LVDS1	DESCRIPTION
Short 1-2 (Default)	Set The Voltage Level of Panel to VCC3
Short 2-3	Set The Voltage Level of Panel to VCC

Table 5-5: LVDS LCD Voltage Selection Jumper Settings

The LVDS Voltage Selection jumper location. is shown in **Figure 5-16**.

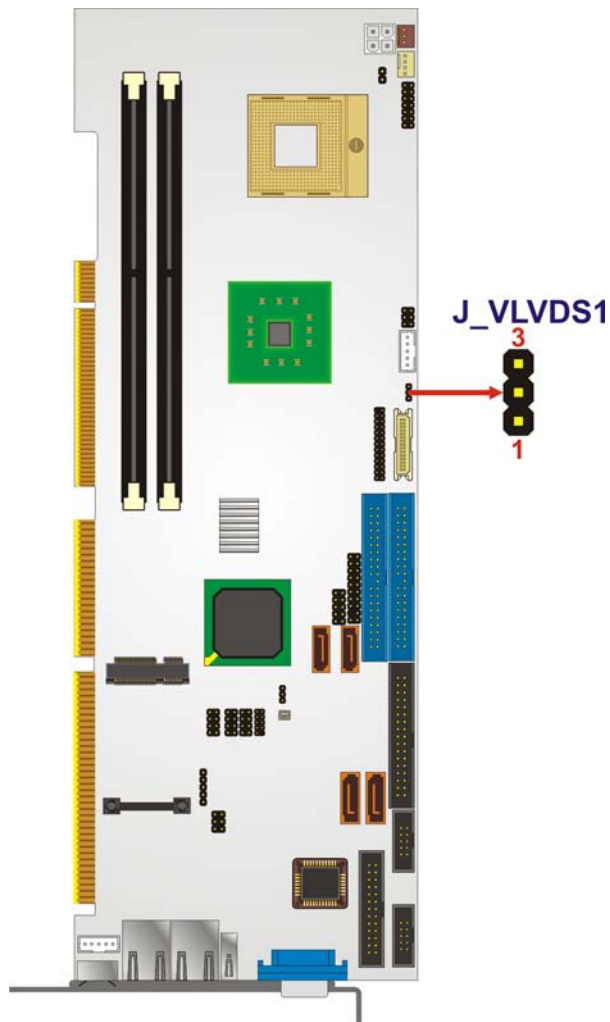

Figure 5-16: LVDS Voltage Selection Jumper Pinout Locations

5.5.4 LAN Power Selection

Jumper Label:	JLAN_PWR1
Jumper Type:	6-pin header
Jumper Settings:	See Table 5-6
Jumper Location:	See Figure 5-17

The **LAN Power Selection** jumper allows the LAN (LAN1 and LAN2) power to be set. The **LAN Power Selection** jumper settings are shown in **Table 5-6**.

WSB-9452 PICMG 1.0 CPU Card

LAN Power Select	Description
Short 1-3	LAN1 uses 3.3V_Dual
Short 3-5	LAN1 uses 3.3V
Short 2-4	LAN2 uses 3.3V_Dual
Short 4-6	LAN2 uses 3.3V

Table 5-6: LCD Voltage Selection Jumper Settings

The LAN Power Selection jumper location is shown in **Figure 5-17**.

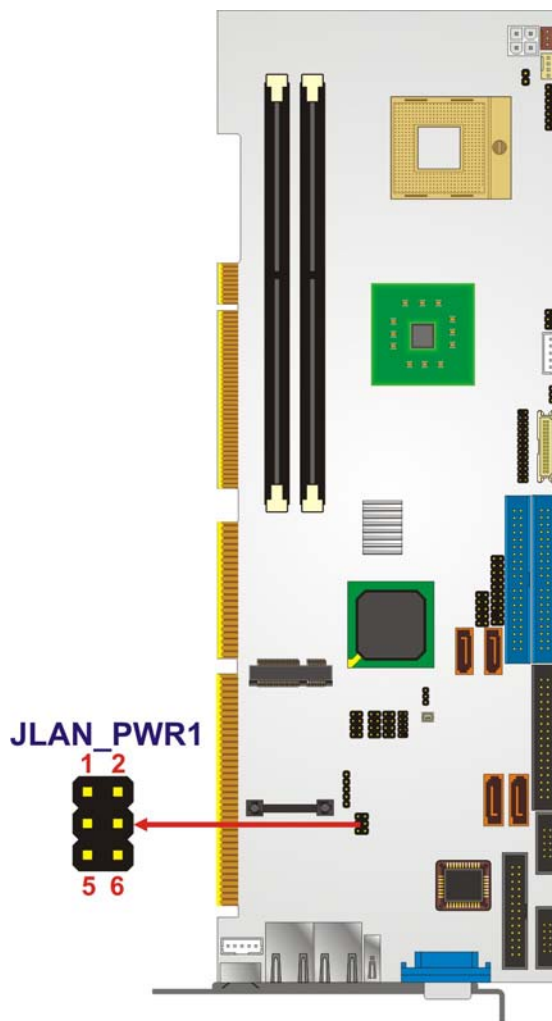

Figure 5-17: LAN Power Selection Jumper Location

5.6 Chassis Installation

After the CPU, the cooling kit, and the DIMM modules have been installed and after the internal peripheral connectors have been connected to the peripheral devices and the jumpers have been configured, the CPU Card can be mounted into a chassis.

To mount the CPU Card into a chassis please refer to the chassis user guide that came with the product.

5.7 Rear Panel Connectors

5.7.1 Keyboard and Mouse Connection

A PS/2 keyboard and a PS/2 mouse can be connected to the appropriate PS/2 connector on the rear panel.

5.7.2 VGA Port Installation

The conventional CRT monitor connector is a 15-pin, female D-SUB connector. Pin assignments can be seen in that can be connected to external monitors.

5.7.3 Ethernet Connection

The rear panel RJ-45 connectors can be connected to an external LAN and communicate with data transfer rates up to 1Gb/s.

5.7.4 USB Connection

The rear panel USB connector provides easier and quicker access to external USB devices. The rear panel USB connector is a standard connector and can easily be connected to other USB devices.

Chapter

6

AMI BIOS Setup

6.1 Introduction

A licensed copy of AMI BIOS is preprogrammed into the ROM BIOS. The BIOS setup program allows users to modify the basic system configuration. This chapter describes how to access the BIOS setup program and the configuration options that may be changed.

6.1.1 Starting Setup

The AMI BIOS is activated when the computer is turned on. The setup program can be activated in one of two ways.

1. Press the **DELETE** key as soon as the system is turned on or
2. Press the **DELETE** key when the “**Press Del to enter SETUP**” message appears on the screen.

If the message disappears before, restart the computer and try again.

6.1.2 Using Setup

Use the arrow keys to highlight items, press **ENTER** to select, use the “+” and “-” keys to change entries, press **F1** for help and press **Esc** to quit. Navigation keys are shown in.

Key	Function
Up arrow	Move to previous item
Down arrow	Move to next item
Left arrow	Move to the item on the left hand side
Right arrow	Move to the item on the right hand side
Esc key	Main Menu – Quit and not save changes into CMOS Status Page Setup Menu and Option Page Setup Menu -- Exit current page and return to Main Menu
“+” key	Increase the numeric value or make changes
“-” key	Decrease the numeric value or make changes
F1 key	General help, only for Status Page Setup Menu and Option Page Setup Menu

WSB-9452 PICMG 1.0 CPU Card

F2 /F3 key	Change color from total 16 colors. F2 to select color forward.
F10 key	Save all the CMOS changes, only for Main Menu

Table 6-1: BIOS Navigation Keys

6.1.3 Getting Help

When **F1** is pressed a small help window describing the appropriate keys to use and the possible selections for the highlighted item appears. To exit the Help Window press **Esc** or the **F1** key again.

6.1.4 Unable to Reboot after Configuration Changes

If the computer cannot boot after changes to the system configuration is made, CMOS defaults. Use the jumper described in **Chapter 4, Section 5.5.1**.

6.1.5 BIOS Menu Bar

The **menu bar** on top of the BIOS screen has the following main items:

- **Main** Changes the basic system configuration.
- **Advanced** Changes the advanced system settings.
- **PCIPnP** Changes the advanced PCI/PnP Settings
- **Boot** Changes the system boot configuration.
- **Security** Sets User and Supervisor Passwords.
- **Chipset** Changes the chipset settings.
- **Exit** Selects exit options and loads default settings

The following sections completely describe the configuration options found in the menu items at the top of the BIOS screen and listed above.

6.2 Main

When the **BIOS Setup** program is entered, the **Main** menu (**BIOS Menu 1**) appears. The **Main** menu gives an overview of the basic system information.

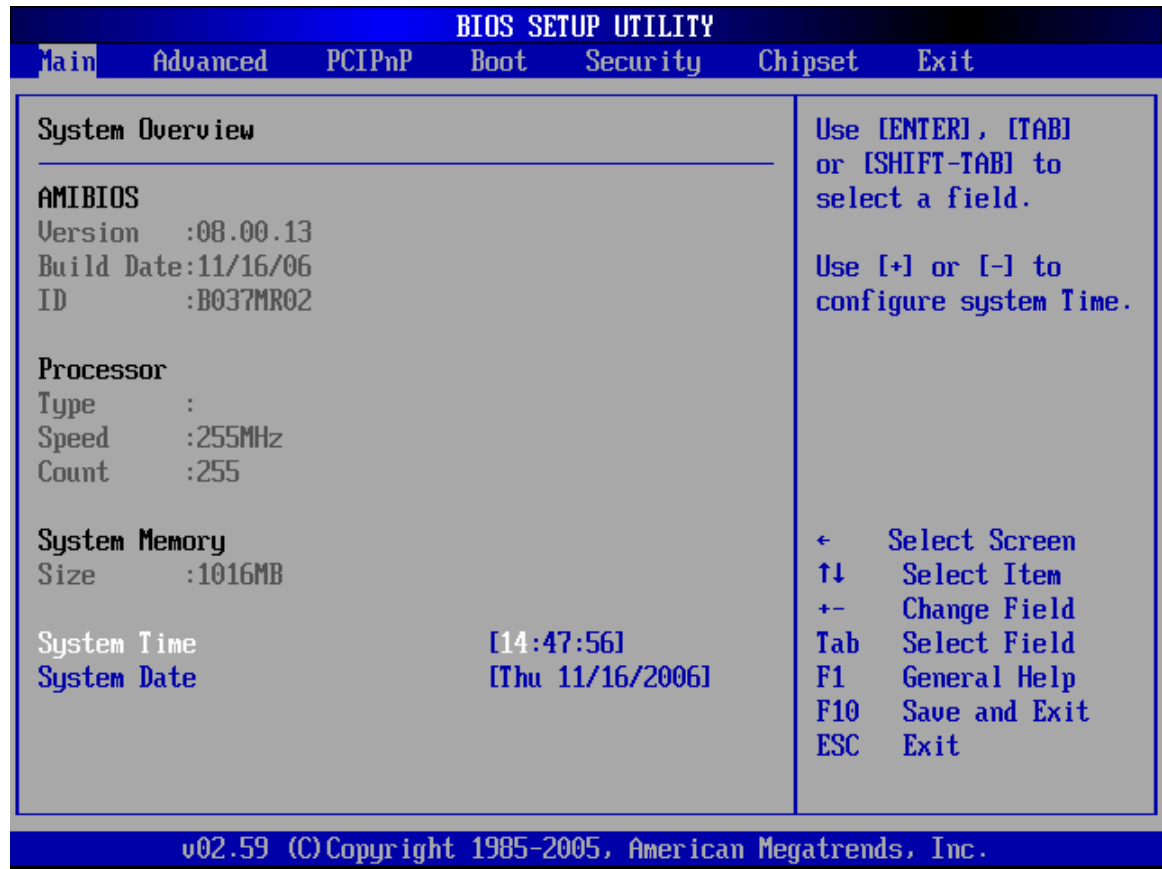

BIOS Menu 1: Main

→ System Overview

The **System Overview** lists a brief summary of different system components. The fields in **System Overview** cannot be changed. The items shown in the system overview include:

- **AMI BIOS:** Displays auto-detected BIOS information
 - **Version:** Current BIOS version
 - **Build Date:** Date the current BIOS version was made
 - **ID:** Installed BIOS ID

WSB-9452 PICMG 1.0 CPU Card

- **Processor:** Displays auto-detected CPU specifications
 - **Type:** Names the currently installed processor
 - **Speed:** Lists the processor speed
 - **Count:** The number of CPUs on the motherboard
- **System Memory:** Displays the auto-detected system memory.
 - **Size:** Lists memory size

The **System Overview** field also has two user configurable fields:

- **System Time [xx:xx:xx]:** The system time is set here.
- **System Date [Day xx/xx/xxxx]:** The system date is set here.

6.3 Advanced

The **Advanced** menu (**BIOS Menu 2**) allows access to the CPU and peripheral device configuration options through the following sub-menus:



WARNING:

Setting the wrong values in the sections below may cause the system to malfunction. Make sure that the settings made are compatible with the hardware.

- **CPU Configuration** (see Section 6.3.1)
- **IDE Configuration** (see Section 6.3.2)
- **Floppy Configuration** (see Section 6.3.3)
- **SuperIO Configuration** (see Section 6.3.4)
- **Hardware Health Configuration** (see Section 6.3.5)
- **ACPI Configuration** (see Section 6.3.6)
- **APM Configuration** (see Section 6.3.7)
- **MPS Configuration** (see Section 6.3.8)
- **Remote Access Configuration** (see Section 6.3.9)
- **Trusted Computing** (see Section 6.3.10)
- **USB Configuration** (see Section 6.3.11)

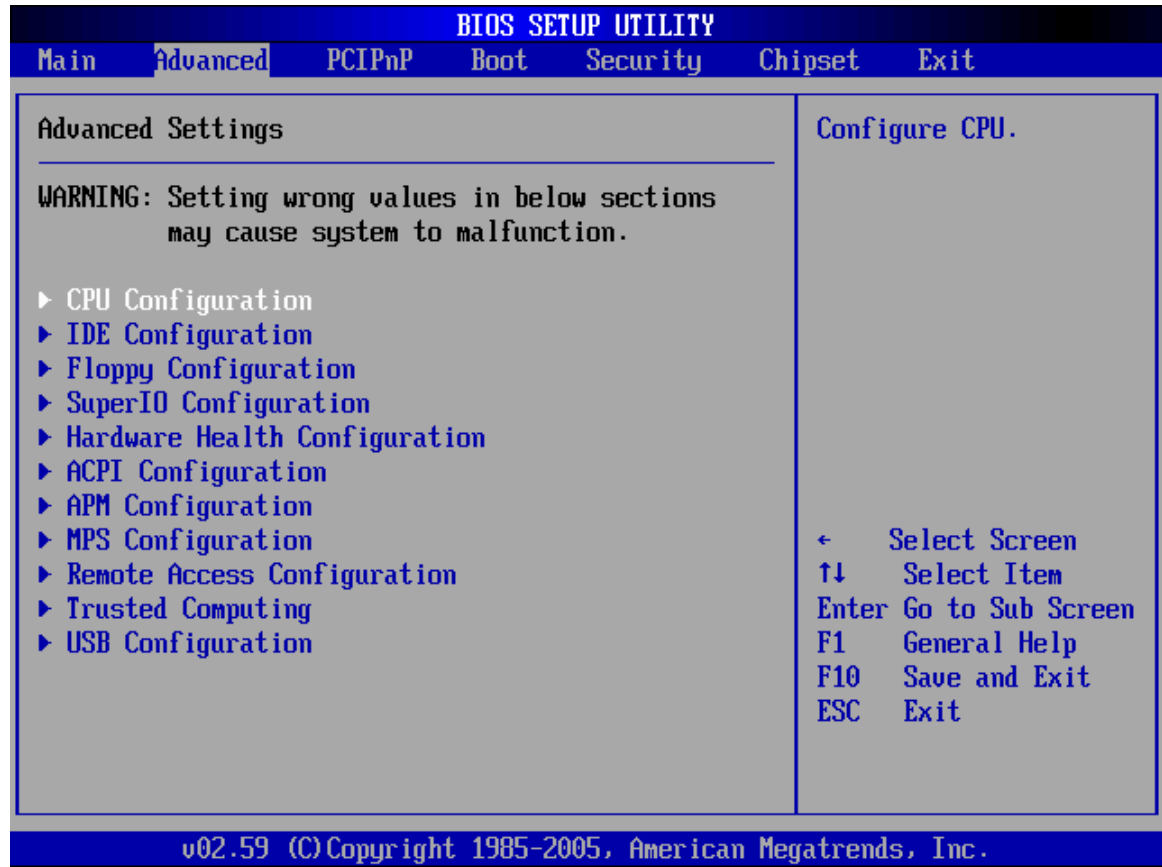

BIOS Menu 2: Advanced

6.3.1 CPU Configuration

The **CPU Configuration** menu (**BIOS Menu 3**) shows detailed CPU specifications and CPU configuration options.

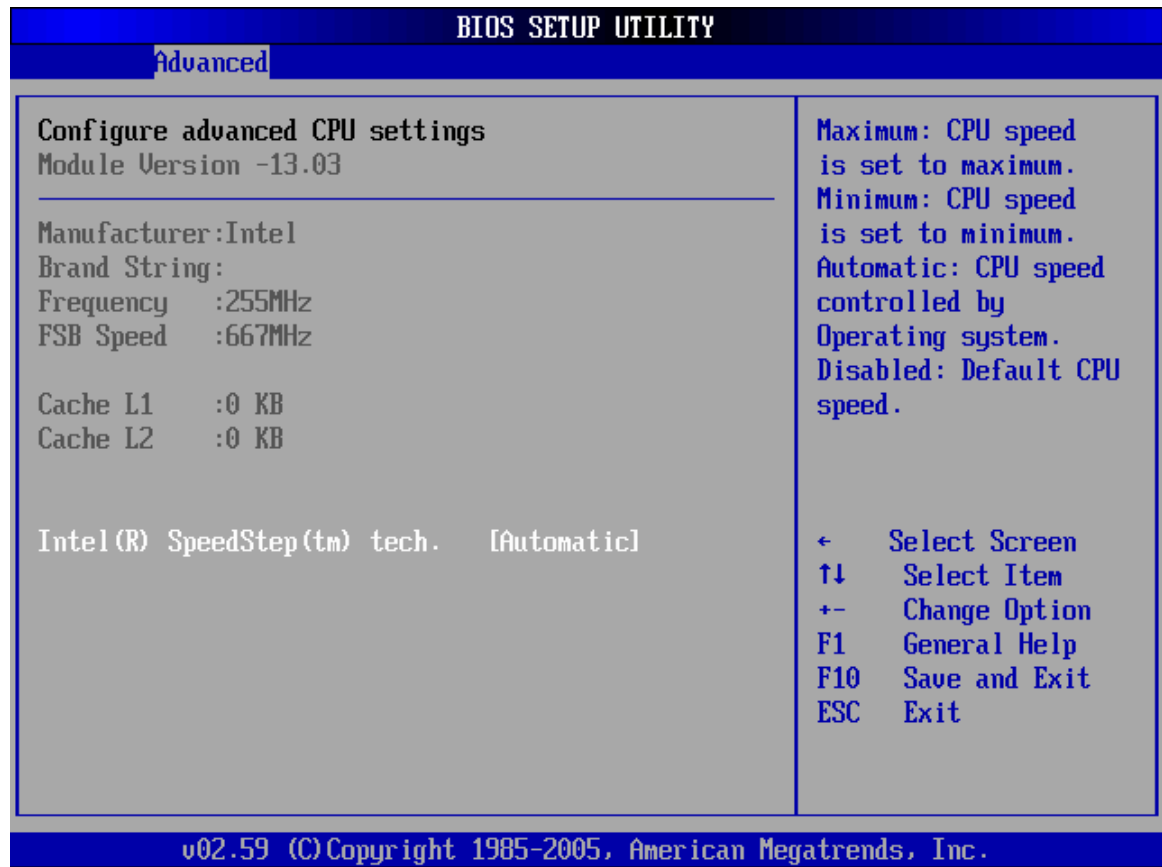

BIOS Menu 3: CPU Configuration

The CPU Configuration menu (**BIOS Menu 3**) lists the following CPU details:

- **Manufacturer:** Lists the name of the CPU manufacturer
- **Brand String:** Lists the brand name of the CPU being used
- **Frequency:** Lists the CPU processing speed
- **FSB Speed:** Lists the FSB speed
- **Cache L1:** Lists the CPU L1 cache size
- **Cache L2:** Lists the CPU L2 cache size

The following **CPU Configuration** menu item can be configured.

→ **Intel(R) SpeedStep(tm) tech. [Automatic]**

Use the **Intel(R) SpeedStep(tm) tech.** option to enable or disable the Enhanced Intel® SpeedStep® Technology (EIST) feature, which allows power settings adjustment in the operating system.

- | | | |
|------------------------|---------|--|
| → Disabled | | EIST feature is disabled; the system runs at the default CPU speed |
| → Automatic | DEFAULT | The operating system controls the CPU speed. |
| → Maximum Speed | | CPU speed is set to maximum |
| → Minimum Speed | | CPU speed is set to minimum |

6.3.2 IDE Configuration

The **IDE Configuration** menu (**BIOS Menu 4**) allows changes to the configurations for the IDE devices installed in the system.

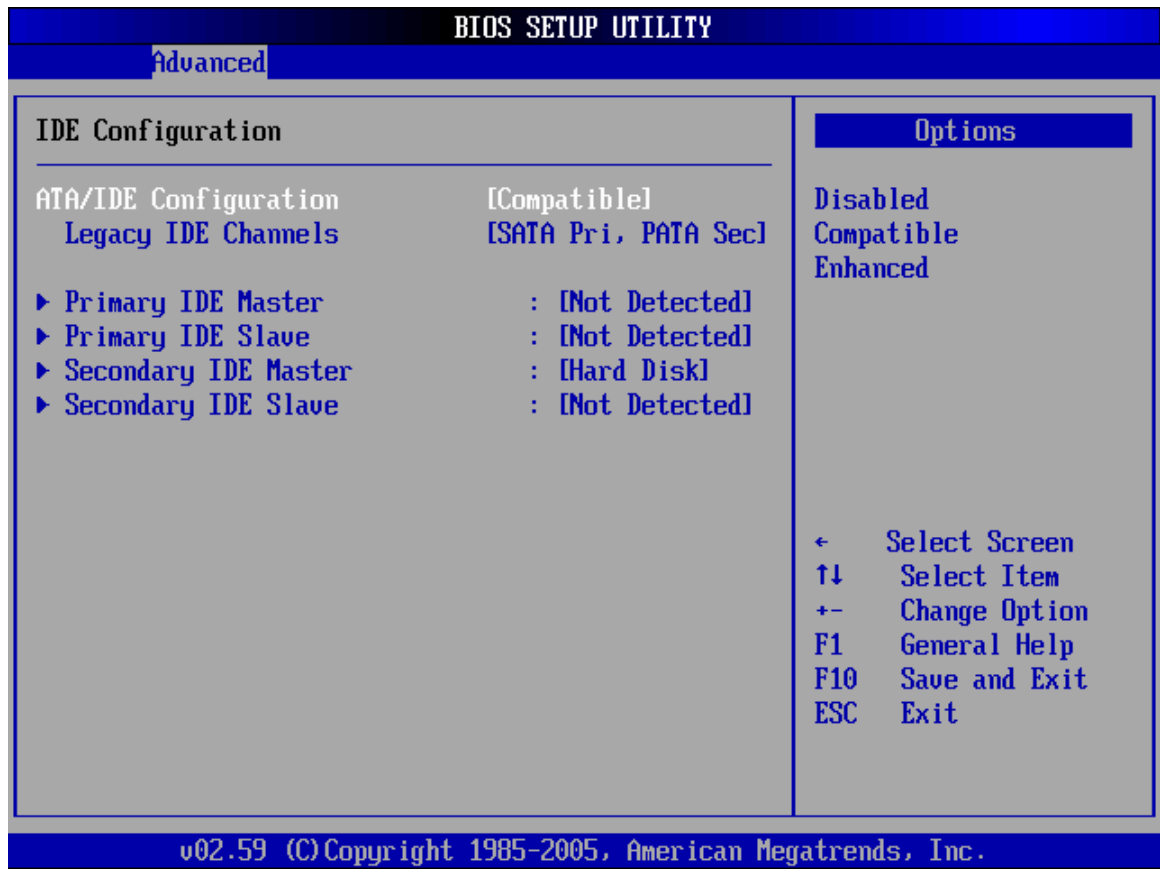

BIOS Menu 4: IDE Configuration

→ **ATA/IDE Configuration [Compatible]**

The **ATA/IDE Configuration** BIOS option allows the user to configure the ATA/IDE device mode.

- **Disabled** Disable all ATA/IDE ports. No Primary/Secondary IDE mode is presented for configuration
- **Compatible** DEFAULT Up to 4 HDDs can be used, two for SATA and the other for PATA IDE. If this option is selected, “Legacy IDE Channels” option is presented for configuration.
- **Enhanced** If this option is selected, “Configure SATA as” and “Configure SATA channels” options are presented for configuration.

→ Legacy IDE Channels [SATA Pri, PATA Sec]

Use the **Legacy IDE Channels** option configures PATA and SATA resources for operating systems that require legacy IDE operation.

- **SATA Only** Enable up to two SATA devices
- **Reserved** The legacy IDE channels are reserved
- **SATA Pri, PATA Sec** DEFAULT This option allows the system to access the SATA devices before the primary IDE devices
- **PATA Only** Enable the two primary IDE devices. Select this option only when the two primary IDE devices are available

→ IDE Master and IDE Slave

When entering setup, BIOS auto detects the presence of IDE devices. This displays the status of the auto detected IDE devices. The following IDE devices are detected and are shown in the **IDE Configuration** menu:

- Primary IDE Master
- Primary IDE Slave

WSB-9452 PICMG 1.0 CPU Card

- Secondary IDE Master
- Secondary IDE Slave

The **IDE Configuration** menu (**BIOS Menu 4**) allows changes to the configurations for the IDE devices installed in the system. If an IDE device is detected, and one of the above listed four BIOS configuration options are selected, the IDE configuration options shown in **Section 6.3.2.1** appear.

6.3.2.1 IDE Master, IDE Slave

IDE Master and IDE Slave configuration options for both primary and secondary IDE devices are shown in the BIOS menu below.

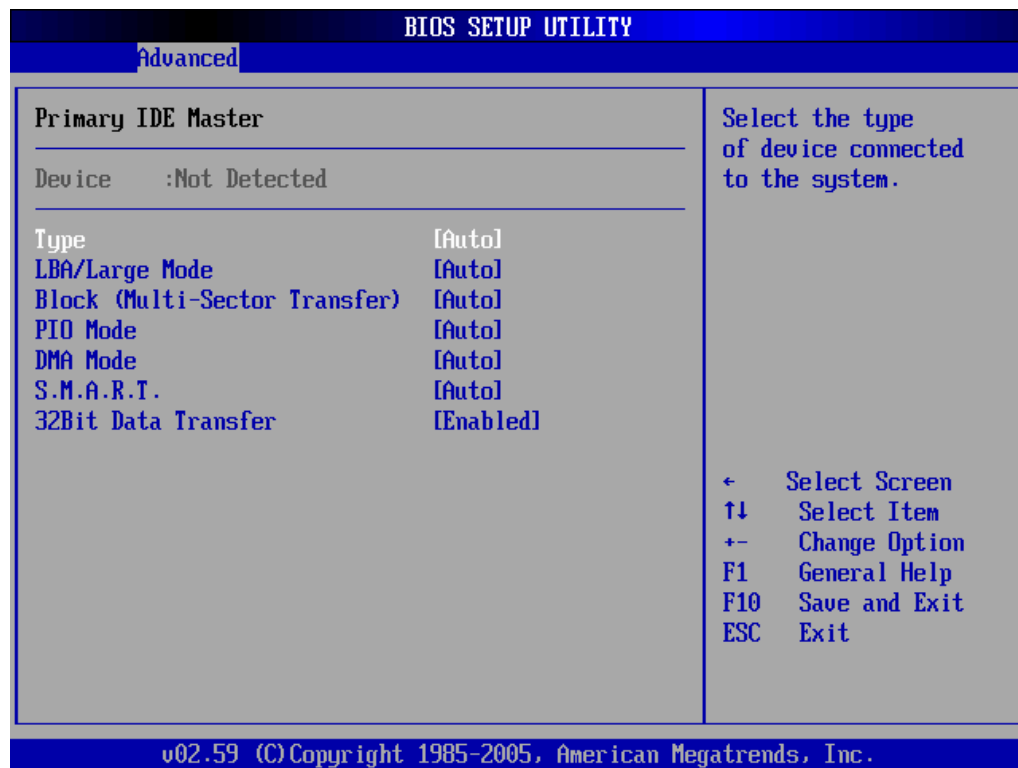

BIOS Menu 5: IDE Master and IDE Slave Configuration

➔ Type [Auto]

The **Type** BIOS option determines the type of device that the AMIBIOS attempts to boot from after the Power-On Self-Test (POST) has completed.

- **Not Installed** Selecting this value prevents the BIOS from searching for an IDE disk drive on the specified channel.

- **Auto** DEFAULT This selection enables the BIOS to auto detect the IDE disk drive type attached to the specified channel. This setting should be used if an IDE hard disk drive is attached to the specified channel.

- **CD/DVD** The CD/DVD option specifies that an IDE CD-ROM drive is attached to the specified IDE channel. The BIOS does not attempt to search for other types of IDE disk drives on the specified channel.

- **ARMD** This option specifies an ATAPI Removable Media Device. These include, but are not limited to:

- **ZIP**

- **LS-120**

→ **LBA/Large Mode [Auto]**

The **LBA/Large Mode** BIOS option disables or auto detects LBA (Logical Block Addressing). LBA is a method of addressing data on a disk drive. In LBA mode, the maximum drive capacity is 137 GB.

- **Disabled** This selection prevents the BIOS from using the LBA mode control on the specified channel.

- **Auto** DEFAULT This option allows the BIOS to auto detect the LBA mode control on the specified channel.

→ Block (Multi Sector Transfer) [Auto]

- **Disabled** Selecting this option prevents the BIOS from using Multi-Sector Transfer on the specified channel. The data to and from the device occurs one sector at a time.

- **Auto** DEFAULT Selecting this value to allows the BIOS to auto detect the device support for Multi-Sector Transfers on the specified channel. If supported. Select this value to allow the BIOS to auto detect the number of sectors per block for transfer from the hard disk drive to the memory. The data transfer to and from the device occurs multiple sectors at a time.

→ PIO Mode [Auto]

The **PIO Mode** option selects the IDE PIO (Programmable I/O) mode program timing cycles between the IDE drive and the programmable IDE controller. As the PIO mode increases, the cycle time decreases.

- **Auto** DEFAULT This setting allows the BIOS to auto detect the PIO mode. Use this value if the IDE disk drive support cannot be determined.

- **0** PIO mode 0 selected with a maximum transfer rate of 3.3MBps
- **1** PIO mode 1 selected with a maximum transfer rate of 5.2MBps
- **2** PIO mode 2 selected with a maximum transfer rate of 8.3MBps
- **3** PIO mode 3 selected with a maximum transfer rate of 11.1MBps
- **4** PIO mode 4 selected with a maximum transfer rate of 16.6MBps
(This setting generally works with all hard disk drives manufactured after 1999. For other disk drives, such as IDE CD-ROM drives, check the specifications of the drive.)

→ DMA Mode [Auto]

The **DMA Mode** BIOS selection adjusts the DMA mode options.

- Auto** DEFAULT The BIOS auto detects the DMA mode. Use this value if the IDE disk drive support cannot be determined.

→ S.M.A.R.T [Auto]

The Self-Monitoring Analysis and Reporting Technology (SMART) feature can help predict impending drive failures. The **S.M.A.R.T** BIOS option enables or disables this function.

- Auto** DEFAULT BIOS to auto detects if the hard disk drive supports S.M.A.R.T. Use this setting if the IDE disk drive support cannot be determined.
- Disabled** Select this value to prevent the BIOS from using the SMART feature.
- Enabled** Select this value to allow the BIOS to use the SMART feature on support hard disk drives.

→ 32Bit Data Transfer [Enabled]

The **32Bit Data Transfer** BIOS option enables or disables 32-bit data transfers.

- Disabled** Prevents the BIOS from using 32-bit data transfers.
- Enabled** DEFAULT Allows BIOS to use 32-bit data transfers on support hard disk drives.

6.3.3 Floppy Configuration

Use the **Floppy Configuration** menu (**BIOS Menu 6**) to set or change the configurations for floppy disk drives.



BIOS Menu 6: Floppy Configuration

→ Floppy A/B [1.44 MB 3½"]

The **Floppy A/B** configuration option determines the types of the floppy drive installed in the system. The following configuration options are available.

- Disabled
- 360 KB 5¼"
- 1.2 MB 5¼"
- 720 KB 3½"
- 1.44 MB 3½"
- 2.88 MB 3½"

6.3.4 Super IO Configuration

The **Super IO Configuration** menu (**BIOS Menu 7**) sets or changes the configurations for the FDD controllers, parallel ports and serial ports.

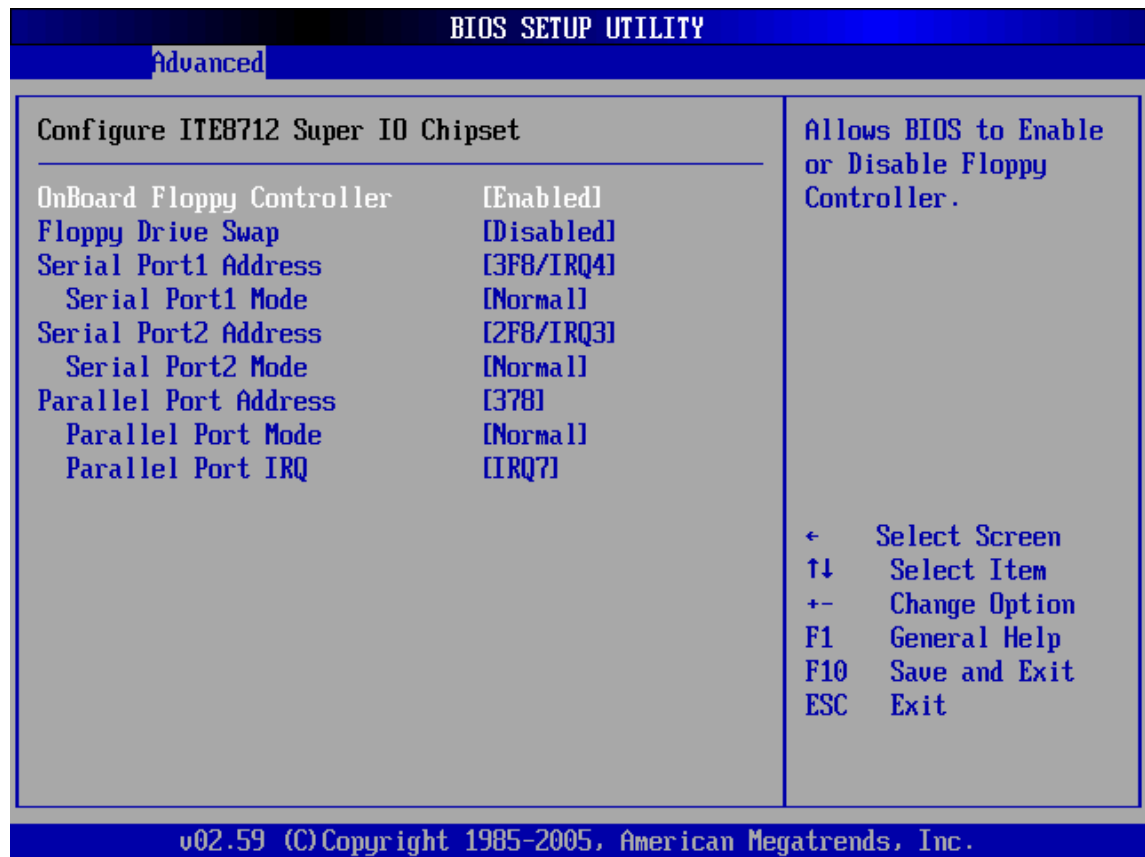

BIOS Menu 7: Super IO Configuration

WSB-9452 PICMG 1.0 CPU Card

→ On-board Floppy Controller [Enabled]

Use the **On-board Floppy Controller** to enable or disable the floppy controller. If a floppy disk is not being used in the system, disabling this option frees up system resources that can be redirected elsewhere in the system.

- **Disabled** Allows BIOS to disable the floppy controller
- **Enabled** DEFAULT Allows BIOS to enable the floppy controller

→ Floppy Drive Swap [Disabled]

Use the **Floppy Drive Swap** option to designate drive A as drive B and drive B as drive A.

- **Disabled** DEFAULT Cannot designate A or B to a floppy drive without changing the physical connection
- **Enabled** Can designate A or B to a floppy drive without changing the physical connection

→ Serial Port1 Address [3F8/IRQ4]

The **Serial Port1 Address** option allows BIOS to select the Serial Port 1 base address.

- **Disabled** No base address is assigned to Serial Port 1
- **3F8/IRQ4** DEFAULT Serial Port 1 I/O port address is 3F8 and the interrupt address is IRQ4
- **3E8/IRQ4** Serial Port 1 I/O port address is 3E8 and the interrupt address is IRQ4
- **2E8/IRQ3** Serial Port 1 I/O port address is 2E8 and the interrupt address is IRQ3

→ **Serial Port1 Mode [Normal]**

Allows BIOS to select the mode for Serial Port 1.

- **Normal** DEFAULT Serial Port 1 mode is normal
- **ASK IR** Serial Port 1 mode is ASK IR

→ **Serial Port2 Address [2F8/IRQ3]**

The **Serial Port2 Address** option allows BIOS to select the Serial Port 2 base address.

- **Disabled** No base address is assigned to Serial Port 2
- **2F8/IRQ3** DEFAULT Serial Port 2 I/O port address is 3F8 and the interrupt address is IRQ3
- **3E8/IRQ4** Serial Port 2 I/O port address is 3E8 and the interrupt address is IRQ4
- **2E8/IRQ3** Serial Port 2 I/O port address is 2E8 and the interrupt address is IRQ3

→ **Serial Port2 Mode [Normal]**

Allows BIOS to select the mode for Serial Port 2.

- **Normal** DEFAULT Serial Port 2 mode is normal
- **IrDA** Serial Port 2 mode is IrDA
- **ASK IR** Serial Port 2 mode is ASK IR

→ Parallel Port Address [Disabled]

Use the **Parallel Port Address** option to select the parallel port base address.

- **Disabled** DEFAULT No base address is assigned to the Parallel Port
- **378** Parallel Port I/O port address is 378
- **278** Parallel Port I/O port address is 278
- **3BC** Parallel Port I/O port address is 3BC

→ Parallel Port Mode [Normal]

Use the **Parallel Port Mode** option to select the mode the parallel port operates in.

- **Normal** DEFAULT The normal parallel port mode is the standard mode for parallel port operation.
- **EPP** The parallel port operates in the enhanced parallel port mode (EPP). The EPP mode supports bi-directional communication between the system and the parallel port device and the transmission rates between the two are much faster than the Normal mode.
- **ECP** The parallel port operates in the extended capabilities port (ECP) mode. The ECP mode supports bi-directional communication between the system and the parallel port device and the transmission rates between the two are much faster than the Normal mode
- **ECP+EPP** The parallel port operates in ECP and EPP modes.

→ **Parallel Port IRQ [IRQ7]**

Use the **Parallel Port IRQ** selection to set the parallel port interrupt address.

→ **IRQ5** IRQ5 is assigned as the parallel port interrupt address

→ **IRQ7** **DEFAULT** IRQ7 is assigned as the parallel port interrupt address

6.3.5 Hardware Health Configuration

The **Hardware Health Configuration** menu (**BIOS Menu 8**) shows the operating temperature, fan speeds and system voltages.

BIOS SETUP UTILITY	
Advanced	
Hardware Health Configuration	Fan configuration mode setting
CPU FAN Mode Setting [Full On mode]	
CPU Temperature :34°C/93°F	
System Temperature :49°C/120°F	
PWM Temperature :32°C/89°F	
System FAN Speed :5973 RPM	
CPU Core :1.008 V	
+1.8V :1.776 V	
+3.30V :3.344 V	
+5.00V :4.960 V	
+12.0V :11.795 V	
0.9V :0.880 V	
1.5V :1.488 V	
5USB :4.928 V	
VBAT :3.248 V	
	← Select Screen
	↑↓ Select Item
	+ - Change Option
	F1 General Help
	F10 Save and Exit
	ESC Exit
v02.59 (C) Copyright 1985-2005, American Megatrends, Inc.	

BIOS Menu 8: Hardware Health Configuration

WSB-9452 PICMG 1.0 CPU Card

→ CPU FAN Mode Setting: [Full On mode]

The CPU FAN Mode Setting has the following options:

- **Full On mode** DEFAULT If selected, there are no additional configurable options.

- **Automatic Mode** If selected, the following options will appear with values that can be configured:
 - CPU Temp. Limit of OFF
 - CPU Temp. Limit of Start
 - CPU Temp. Limit of Full
 - CPU Fan Start PWM
 - Slope PWM 1: 0 PWM, 1 PWM (Default), 2 PWM, 4 PWM, 8 PWM, 16 PWM, 32 PWM or 64 PWM

- **PWM Manually mode** If selected, the following option will appear with values that can be configured:
 - CPU Fan PWM Control

The following system parameters and values are shown. The system parameters that are monitored are:

- **System Temperatures:** The following system temperatures are monitored
 - CPU Temperature
 - System Temperature
 - PWM Temperature
- **Fan Speeds:** The CPU cooling fan speed is monitored.
 - System Fan Speed
- **Voltages:** The following system voltages are monitored

- CPU Core
- +1.8V
- +3.30V
- +5.00V
- +12.0V
- 0.9V
- 1.5V
- 5VSB
- VBAT

6.3.6 ACPI Configuration

The **ACPI Configuration** menu (**BIOS Menu 9**) configures the Advanced Configuration and Power Interface (ACPI) and Power Management (APM) options.

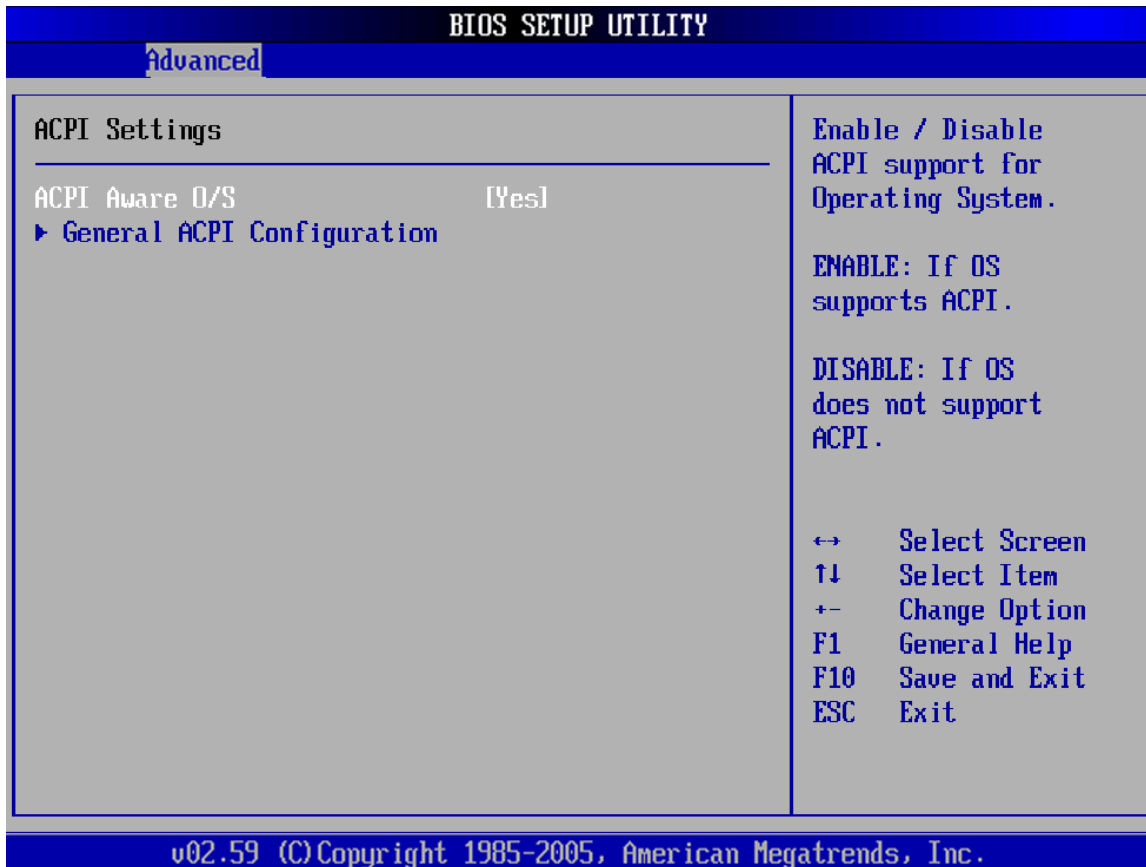

BIOS Menu 9: ACPI Configuration

→ ACPI Aware O/S [Yes]

Use the **ACPI Aware O/S** option to enable the system to configure ACPI power saving options. ACPI can only be implemented if the system OS complies with the ACPI standard. Windows 98, Windows 2000, and Windows XP all comply with ACPI.

- **No** Disables the ACPI support for the OS. This selection should be disabled if the OS does not support ACPI
- **Yes DEFAULT** Enables the ACPI support for the operating system. This selection should be enabled if the OS does support ACPI

6.3.6.1 General ACPI Configuration

Use the **General ACPI Configuration** menu (**BIOS Menu 10**) to select the ACPI state when the system is suspended.

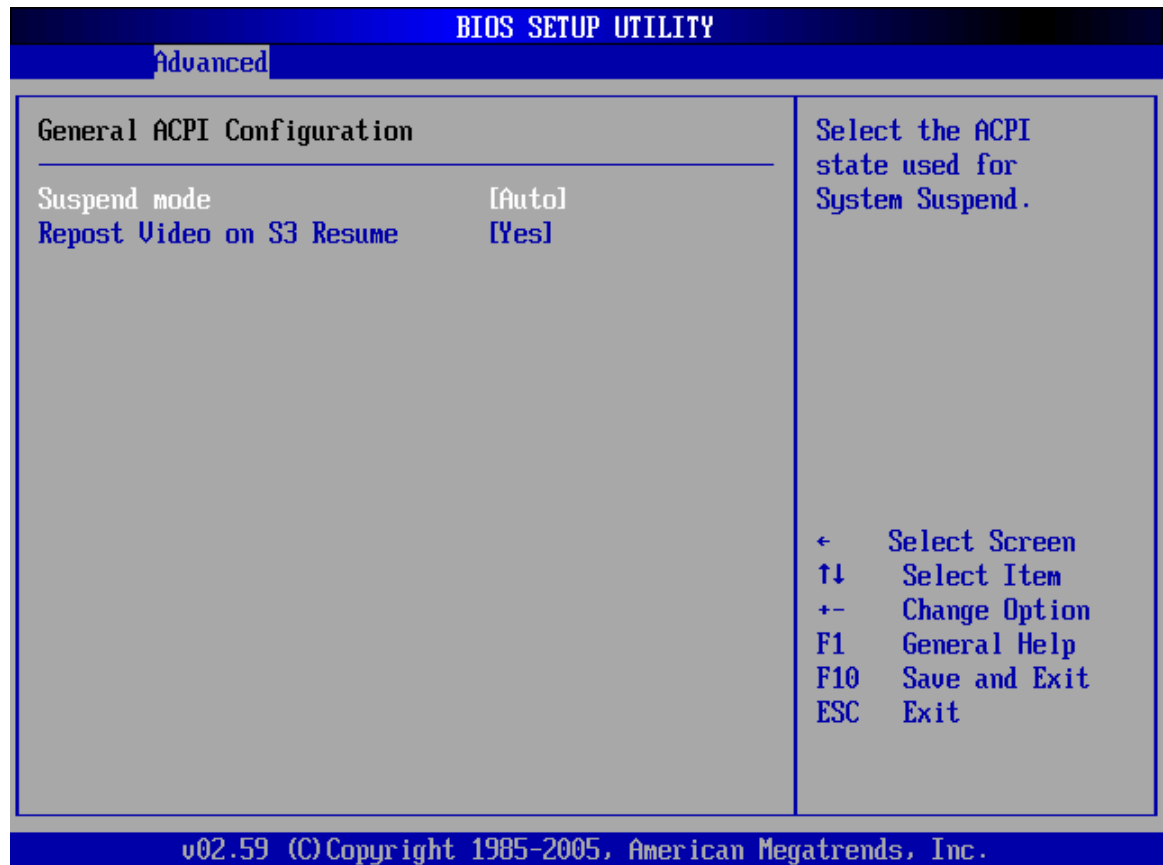

BIOS Menu 10: General ACPI Configuration

WSB-9452 PICMG 1.0 CPU Card

→ Suspend mode [Auto]

Use the **Suspend Mode** option to specify the sleep state the system enters when it is not being used.

- **Auto** The OS selects the sleep state when then system is not being used.
- **S1 (POS)** The system enters S1(POS) sleep state. The system appears off. The CPU is stopped; RAM is refreshed; the system is running in a low power mode.
- **S3 (STR)** DEFAULT The system enters a S3(STR) sleep state. The CPU has no power; RAM is in slow refresh; the power supply is in a reduced power mode.

→ Repost Video on S3 Resume [Yes]

Use the **Repost Video on S3 Resume** option to enable video repost support, allowing the video BIOS to be initialized when coming out of S3 state.

- **Yes** DEFAULT The video BIOS will be initialized when coming out of S3 state
- **No** The video BIOS will be initialized when coming out of S3 state

6.3.7 APM Configuration

Use the **APM Configuration** menu (**BIOS Menu 11**) to select the advanced power management.

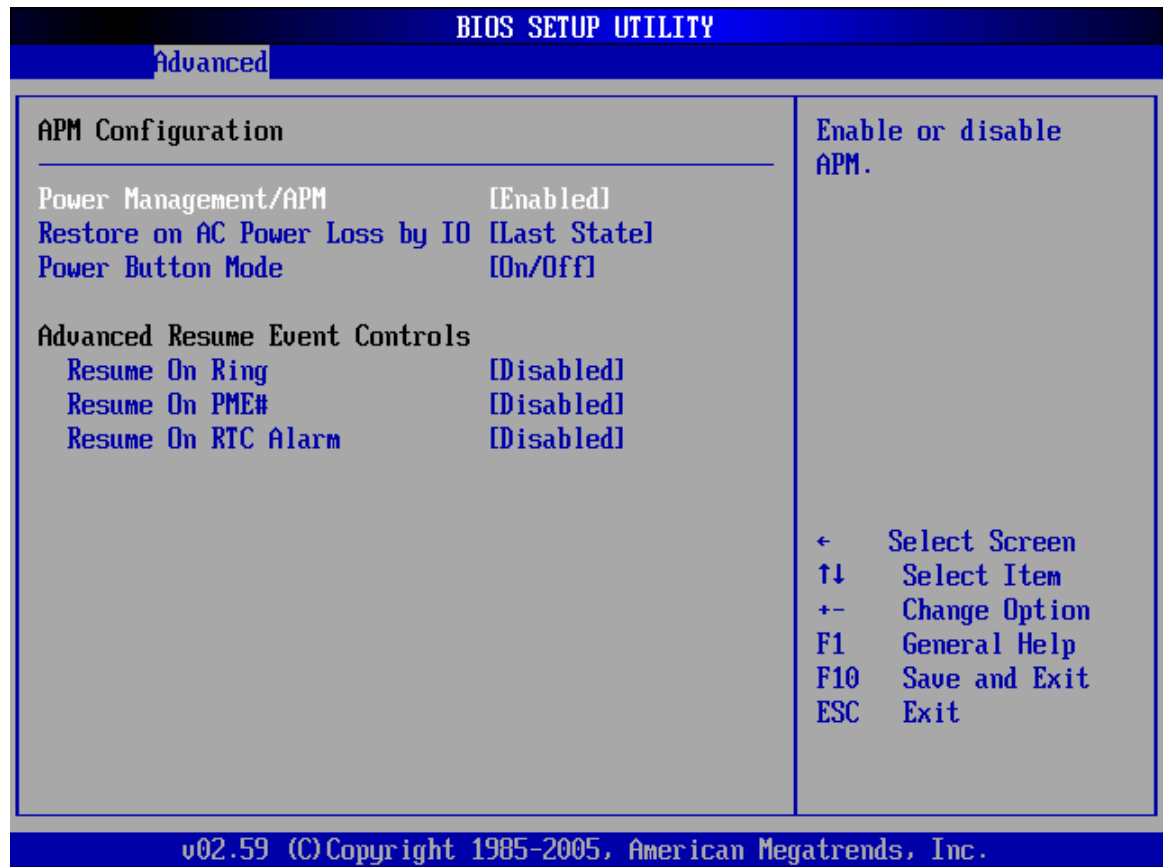

BIOS Menu 11: APM Configuration

→ Power Management/APM [Enabled]

The **Power Management/APM** BIOS option accesses the advanced power management features.

- **Disabled** Disables the Advanced Power Management (APM) feature
- **Enabled** DEFAULT Enables the APM feature

→ **Restore on AC Power Loss by IO [Last State]**

The **Restore on AC Power Loss by IO** BIOS option specifies what state the system returns to if there is a sudden loss of power to the system.

- **Last State** DEFAULT The system returns to its previous state. If it was on, it turns itself on. If it was off, it remains off.
- **Power Off** The system remains turned off
- **Power On** The system turns on

→ **Power Button Mode [On/Off]**

The **Power Button Mode** BIOS specifies how the power button functions.

- **On/Off** DEFAULT When the power button is pressed the system is either turned on or off
- **Suspend** When the power button is pressed the system goes into suspend mode

→ **Resume on Ring [Disabled]**

The **Resume on Ring** BIOS option specifies if the system will be roused from a suspended or standby state when there is activity on the RI (ring in) modem line. That is, the system will be roused by an incoming call on a modem.

- **Disabled** DEFAULT Wake event not generated by an incoming call
- **Enabled** Wake event generated by an incoming call

→ **Resume on PME# [Disabled]**

The **Resume on PME#** BIOS option specifies if the system will be roused from a suspended or standby state when there is activity on the PCI PME (power management event) controller.

- **Disabled** DEFAULT Wake event not generated by PCI PME controller activity
- **Enabled** Wake event generated by PCI PME controller activity

→ **Resume On RTC Alarm [Disabled]**

The **Resume On RTC Alarm** determines when the computer will be roused from a suspended state.

- **Disabled** DEFAULT The real time clock (RTC) cannot generate a wake event
- **Enabled** If selected, the following will appear with values that can be selected:

- **RTC Alarm Date (Days)**

- **RTC Alarm Time**

After setting the alarm, the computer will turn itself on from a suspend state when the alarm goes off.

6.3.8 MPS Configuration

Use the **MPS Configuration** menu (**BIOS Menu 12**) to select the multi-processor table.

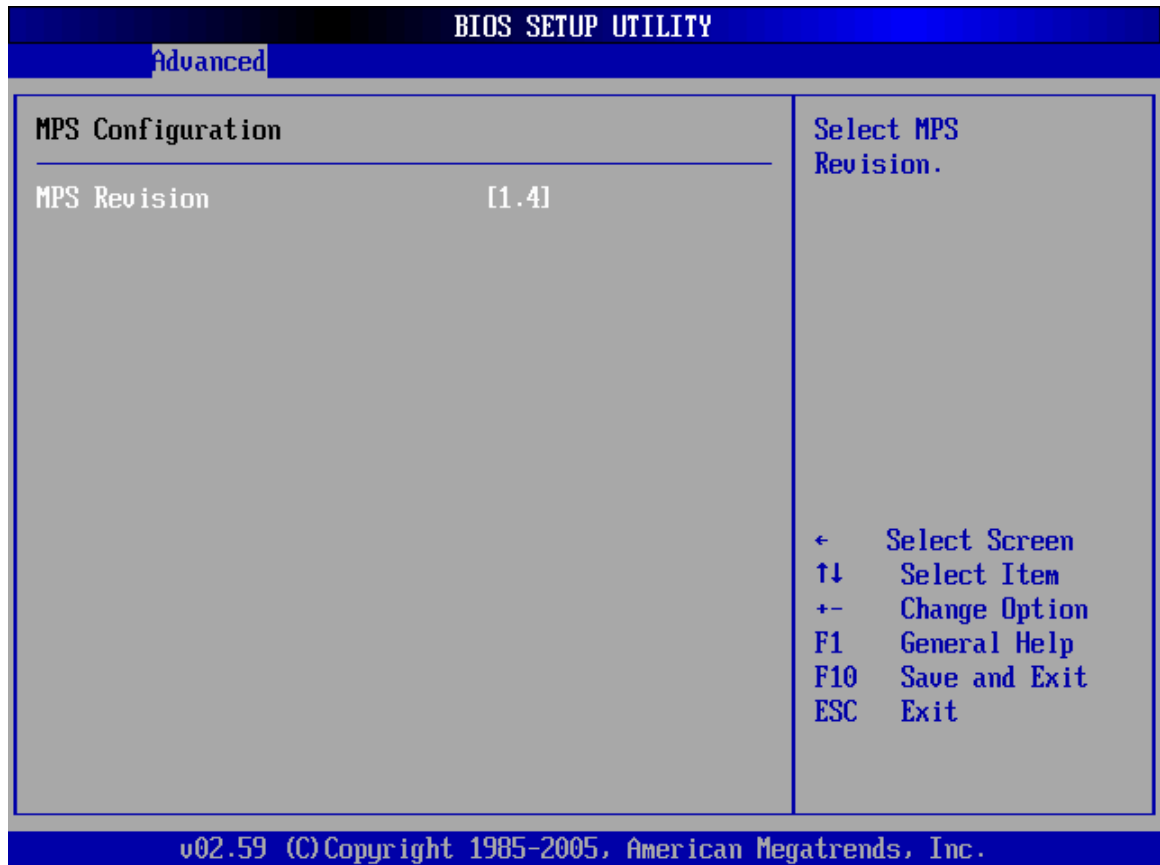

BIOS Menu 12: MPS Configuration

→ MPS Revision [1.4]

Use the **Multiprocessor Specification (MPS) Revision** option to specify the MPS version to be used.

- 1.1 MPS version 1.1 is used
- 1.4 DEFAULT MPS version 1.4 is used

6.3.9 Remote Access Configuration

Use the **Remote Access Configuration** menu (**BIOS Menu 13**) to configure remote access parameters. The **Remote Access Configuration** is an AMIBIOS feature and allows a remote host running a terminal program to display and configure the BIOS settings.

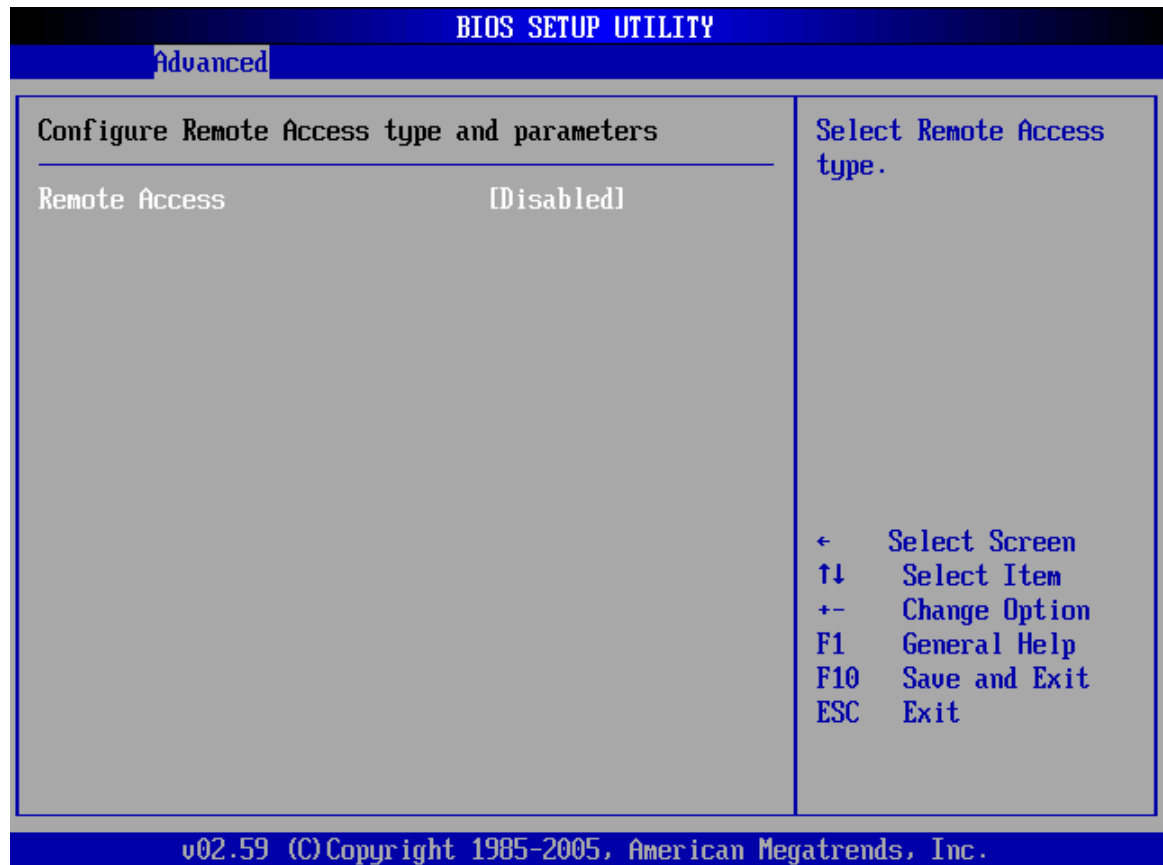

BIOS Menu 13: Remote Access Configuration

→ Remote Access [Disabled]

Use the **Remote Access** option to enable or disable access to the remote functionalities of the system.

- **Disabled** DEFAULT Remote access is disabled.
- **Enabled** Remote access configuration options shown below appear:

- **Serial Port Number**
- **Serial Port Mode**
- **Flow Control**
- **Redirection after BIOS POST**
- **Terminal Type**
- **VT-UTF8 Combo Key Support**
- **Sredir Memory Display Delay**

These configuration options are discussed below.

→ **Serial Port Number [COM1]**

Use the **Serial Port Number** option allows selection of the serial port used for remote access.

- **COM1** DEFAULT System is remotely accessed through COM1
- **COM2** System is remotely accessed through COM2

**NOTE:**

Make sure the selected COM port is enabled through the Super I/O configuration menu.

→ Base Address, IRQ [2F8h,3]

The **Base Address, IRQ** option cannot be configured and only shows the interrupt address of the serial port listed above.

→ Serial Port Mode [115200 8,n,1]

Use the **Serial Port Mode** option to select baud rate through which the console redirection is made. The following configuration options are available

- 115200 8,n,1 DEFAULT
- 57600 8,n,1
- 38400 8,n,1
- 19200 8,n,1
- 09600 8,n,1

**NOTE:**

Identical baud rate setting must be set on the host (a management computer running a terminal software) and the slave

→ Flow Control [None]

Use the **Flow Control** option to report the flow control method for the console redirection application.

WSB-9452 PICMG 1.0 CPU Card

- **None** DEFAULT No control flow,
- **Hardware** Hardware is set as the console redirection
- **Software** Software is set as the console redirection

→ **Redirection After BIOS POST [Always]**

Use the **Redirection After BIOS POST** option to specify when console redirection should occur.

- **Disabled** The console is not redirected after POST
- **Boot Loader** Redirection is active during POST and during Boot Loader
- **Always** DEFAULT Redirection is always active (Some Oses may not work if set to Always)

→ **Terminal Type [ANSI]**

Use the **Terminal Type** BIOS option to specify the remote terminal type.

- **ANSI** DEFAULT The target terminal type is ANSI
- **VT100** The target terminal type is VT100
- **VT-UTF8** The target terminal type is VT-UTF8

→ **VT-UTF8 Combo Key Support [Disabled]**

Use the **VT-UFT8 Combo Key Support** option to enable additional keys that are not provided by VT100 for the PC 101 keyboard.

The VT100 Terminal Definition is the standard convention used to configure and conduct emergency management tasks with UNIX-based servers. VT100 does not support all keys on the standard PC 101-key layout, however. The VT-UTF8 convention makes available additional keys that are not provided by VT100 for the PC 101 keyboard.

- **Disabled** DEFAULT Disables the VT-UTF8 terminal keys
- **Enabled** Enables the VT-UTF8 combination key. Support for ANSI/VT100 terminals

→ **Sredir Memory Display Delay [Disabled]**

Use the **Sredir Memory Display Delay** option to select the delay before memory information is displayed. Configuration options are listed below

- No Delay DEFAULT
- Delay 1 sec
- Delay 2 sec
- Delay 4 sec

6.3.10 Trusted Computing

Use the **Trusted Computing** menu (**BIOS Menu 15**) to configure the trusted computing platform settings.

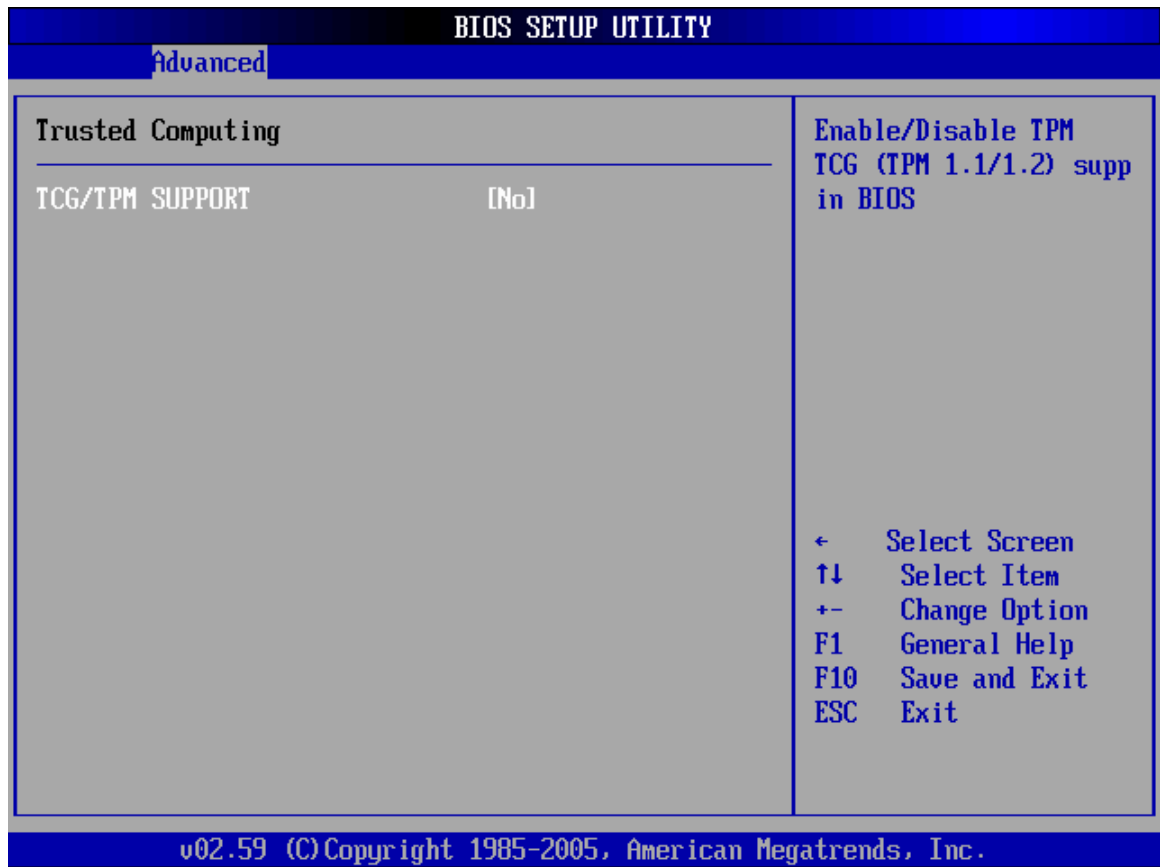

BIOS Menu 14: Trusted Computing Configuration

→ TCG/TPM Support [No]

Use the **TCG/TPM Support** option to enable support for the Trusted Computing Group/Trusted Platform Module (TCG/TPM 1.1/1.2) specification.

- **Yes** Enables TCG/TPM support
- **No** DEFAULT Disables TCG/TPM support

6.3.11 USB Configuration

Use the **USB Configuration** menu (**BIOS Menu 15**) to read USB configuration information and configure the USB settings.

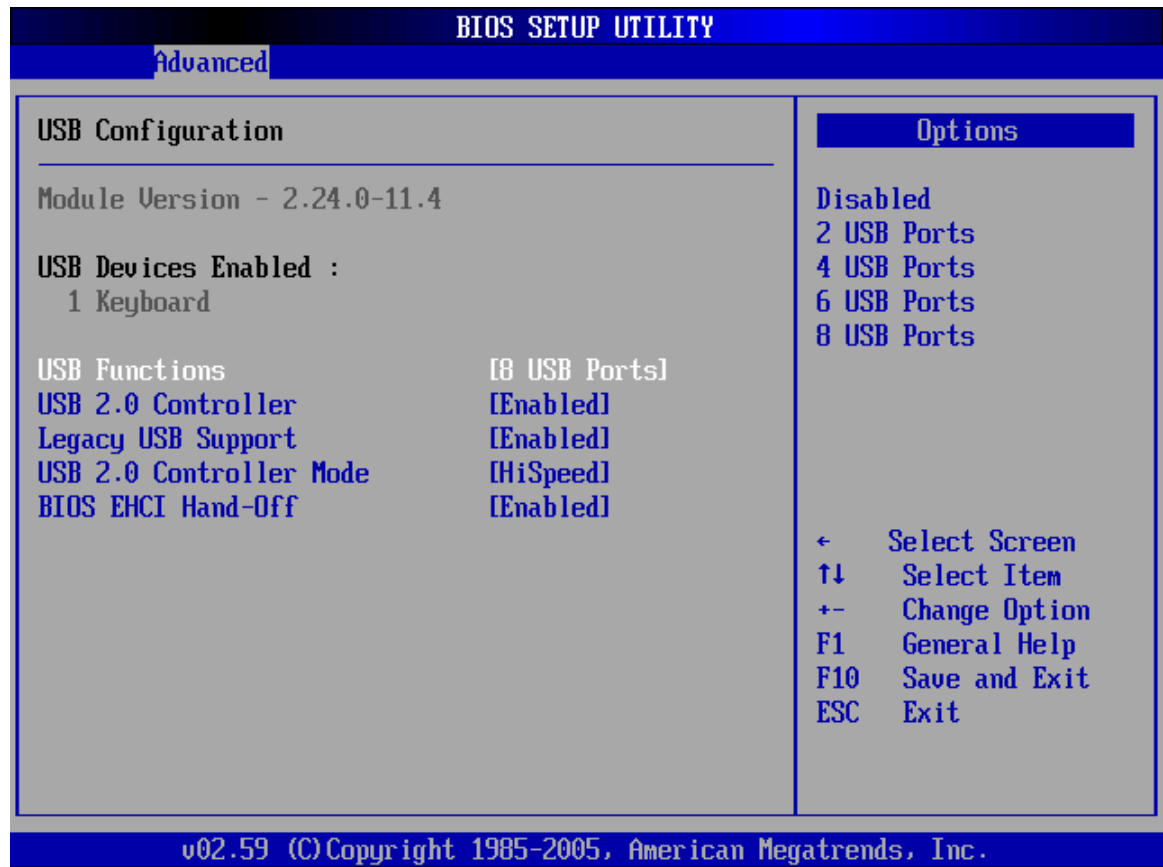

BIOS Menu 15: USB Configuration

→ USB Configuration

The **USB Configuration** field shows the system USB configuration. The items listed are:

- Module Version: x.xxxxx.xxxxx

→ USB Devices Enabled

The **USB Devices Enabled** field lists the USB devices that are enabled on the system

WSB-9452 PICMG 1.0 CPU Card

→ USB Function [8 USB Ports]

Use the **USB Function** BIOS option to disable USB function support or to set the number of USB ports to activate.

- **Disabled** USB function support disabled
- **2 USB Ports** Two USB ports are activated.
- **4 USB Ports** Four USB ports are activated.
- **6 USB Ports** Six USB ports are activated.
- **8 USB Ports** DEFAULT Eight USB ports are activated.

→ USB 2.0 Controller [Enabled]

Use the **USB 2.0 Controller** BIOS option to enable or disable the USB 2.0 controller

- **Enabled** DEFAULT USB 2.0 controller enabled
- **Disabled** USB 2.0 controller disabled

→ Legacy USB Support [Enabled]

Use the **Legacy USB Support** BIOS option to enable USB mouse and USB keyboard support.

Normally if this option is not enabled, any attached USB mouse or USB keyboard does not become available until a USB compatible operating system is fully booted with all USB drivers loaded. When this option is enabled, any attached USB mouse or USB keyboard can control the system even when there is no USB driver loaded onto the system.

- **Disabled** Legacy USB support disabled
- **Enabled** DEFAULT Legacy USB support enabled
- **Auto** Legacy USB support disabled if no USB devices are connected

→ **USB2.0 Controller Mode [HiSpeed]**

Use the **USB2.0 Controller Mode** option to set the speed of the USB2.0 controller.

- **FullSpeed** The controller is capable of operating at 12Mb/s
- **HiSpeed** DEFAULT The controller is capable of operating at 480Mb/s

→ **BIOS EHCI Handoff [Enabled]**

Use the **BIOS EHCI Handoff** option for systems running OSes that do not have EHCI hand-off support. The EHCI ownership change is managed by the EHCI driver.

- **Disabled** Systems with OSes that do not support EHCI can use the EHCI handoff functionality.
- **Enabled** DEFAULT Systems with OSes that do not support EHCI cannot use the EHCI handoff functionality.

6.4 PCI/PnP

Use the **PCI/PnP** menu (**BIOS Menu 16**) to configure advanced PCI and PnP settings.



WARNING:

Setting wrong values for the BIOS selections in the PCIPnP BIOS menu may cause the system to malfunction.

BIOS SETUP UTILITY

Main Advanced **PCIPnP** Boot Security Chipset Exit

Advanced PCI/PnP Settings

WARNING: Setting wrong values in below sections may cause system to malfunction.

Clear NURAM	[No]	▲ Clear NURAM during System Boot. ← Select Screen ↑↓ Select Item +- Change Option F1 General Help F10 Save and Exit ESC Exit ▼
Plug & Play O/S	[No]	
PCI Latency Timer	[64]	
Allocate IRQ to PCI UGA	[Yes]	
Palette Snooping	[Disabled]	
PCI IDE BusMaster	[Enabled]	
OffBoard PCI/ISA IDE Card	[Auto]	
IRQ3	[Available]	
IRQ4	[Available]	
IRQ5	[Available]	
IRQ7	[Available]	
IRQ9	[Available]	
IRQ10	[Available]	
IRQ11	[Available]	

v02.59 (C) Copyright 1985-2005, American Megatrends, Inc.

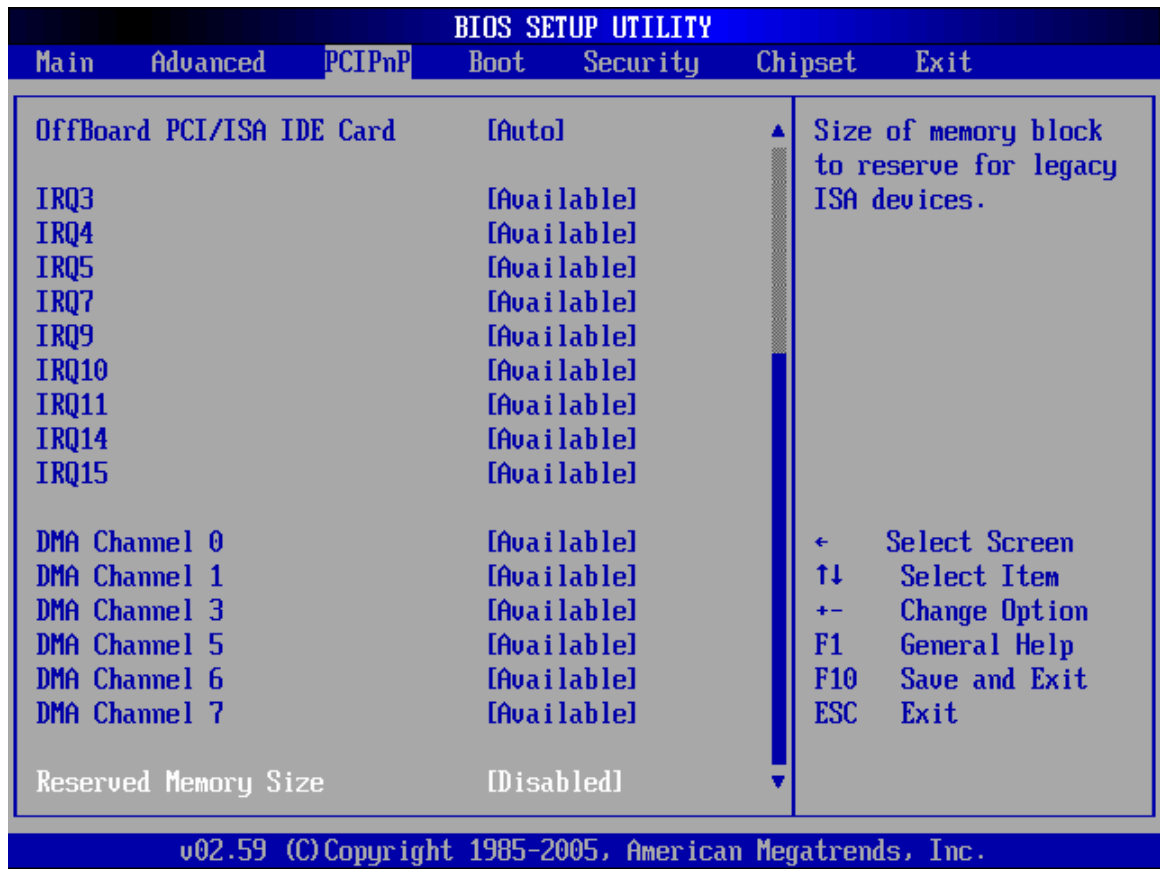

BIOS Menu 16: PCI/PnP Configuration

→ **Clear NVRAM [No]**

Use the **Clear NVRAM** option to specify if the NVRAM (Non-Volatile RAM) is cleared when the power is turned off.

- **No** DEFAULT System does not clear NVRAM during system boot
- **Yes** System clears NVRAM during system boot

→ Plug & Play O/S [No]

Use the **Plug & Play O/S** BIOS option to specify whether system plug and play devices are configured by the operating system or the BIOS.

→ No **DEFAULT** If the operating system does not meet the Plug and Play specifications, this option allows the BIOS to configure all the devices in the system.

→ Yes This setting allows the operating system to change the interrupt, I/O, and DMA settings. Set this option if the system is running Plug and Play aware operating systems.

→ PCI Latency Timer [64]

Use the **PCI Latency Timer** option to specify the PCI latency time. The latency time is measured in units of PCI clock cycles for the PCI device latency timer register. Configuration options are:

- 32
- 64 Default
- 96
- 128
- 160
- 192
- 224
- 248

WSB-9452 PICMG 1.0 CPU Card

→ Allocate IRQ to PCI VGA [Yes]

Use the **Allocate IRQ to PCI VGA** option to restrict the system from giving the VGA adapter card an interrupt address.

- **Yes** **DEFAULT** Assigns an IRQ to a PCI VGA card if card requests IRQ
- **No** Does not assign IRQ to a PCI VGA card even if the card requests an IRQ

→ Palette Snooping [Disabled]

Use the **Palette Snooping** option to enable or disable the palette snooping function.

- **Disabled** **DEFAULT** Unless the VGA card manufacturer requires palette snooping to be enabled, this option should be disabled.
- **Enabled** PCI devices are informed that an ISA based Graphics device is installed in the system so the ISA based Graphics card functions correctly. This does not necessarily indicate a physical ISA adapter card. The graphics chipset can be mounted on a PCI card. Always check with the adapter card manual first, before modifying the default settings in the BIOS.

→ **PCI IDE BusMaster [Enabled]**

Use the **PCI IDE BusMaster** BIOS option to enable or prevent PCI IDE busmastering.

- **Disabled** Busmastering is prevented
- **Enabled** DEFAULT IDE controller on the PCI local bus has mastering capabilities

→ **OffBoard PCI/ISA IDE Card [Auto]**

Use the **OffBoard PCI/ISA IDE Card** BIOS option to select the **OffBoard PCI/ISA IDE Card**.

- **Auto** DEFAULT The location of the Off Board PCI IDE adapter card is automatically detected by the AMIBIOS.
- **PCI Slot 1** PCI Slot 1 is selected as the location of the OffBoard PCI IDE adapter card. Only select this slot if the adapter card is installed in PCI Slot 1.
- **PCI Slot 2** PCI Slot 2 is selected as the location of the OffBoard PCI IDE adapter card. Only select this slot if the adapter card is installed in PCI Slot 2.
- **PCI Slot 3** PCI Slot 3 is selected as the location of the OffBoard PCI IDE adapter card. Only select this slot if the adapter card is installed in PCI Slot 3.
- **PCI Slot 4** PCI Slot 4 is selected as the location of the OffBoard PCI IDE adapter card. Only select this slot if the adapter card is installed in PCI Slot 4.

WSB-9452 PICMG 1.0 CPU Card

- **PCI Slot 5** PCI Slot 5 is selected as the location of the OffBoard PCI IDE adapter card. Only select this slot if the adapter card is installed in PCI Slot 5.

- **PCI Slot 6** PCI Slot 6 is selected as the location of the OffBoard PCI IDE adapter card. Only select this slot if the adapter card is installed in PCI Slot 6.

- **IRQ# [Available]**

Use the **IRQ#** address to specify what IRQs can be assigned to a particular peripheral device.

- **Available** DEFAULT The specified IRQ is available to be used by PCI/PnP devices

- **Reserved** The specified IRQ is reserved for use by Legacy ISA devices

Available IRQ addresses are:

- IRQ3
- IRQ4
- IRQ5
- IRQ7
- IRQ9
- IRQ10
- IRQ 11
- IRQ 14
- IRQ 15

→ DMA Channel# [Available]

Use the **DMA Channel#** option to assign a specific DMA channel to a particular PCI/PnP device.

- | | | |
|--------------------|---------|--|
| → Available | DEFAULT | The specified DMA is available to be used by PCI/PnP devices |
| → Reserved | | The specified DMA is reserved for use by Legacy ISA devices |

Available DMA Channels are:

- DM Channel 0
- DM Channel 1
- DM Channel 3
- DM Channel 5
- DM Channel 6
- DM Channel 7

→ Reserved Memory Size [Disabled]

Use the **Reserved Memory Size** BIOS option to specify the amount of memory that should be reserved for legacy ISA devices.

- | | | |
|-------------------|---------|---|
| → Disabled | DEFAULT | No memory block reserved for legacy ISA devices |
| → 16K | | 16KB reserved for legacy ISA devices |
| → 32K | | 32KB reserved for legacy ISA devices |
| → 64K | | 54KB reserved for legacy ISA devices |

6.5 Boot

Use the **Boot** menu (**BIOS Menu 17**) to configure system boot options.

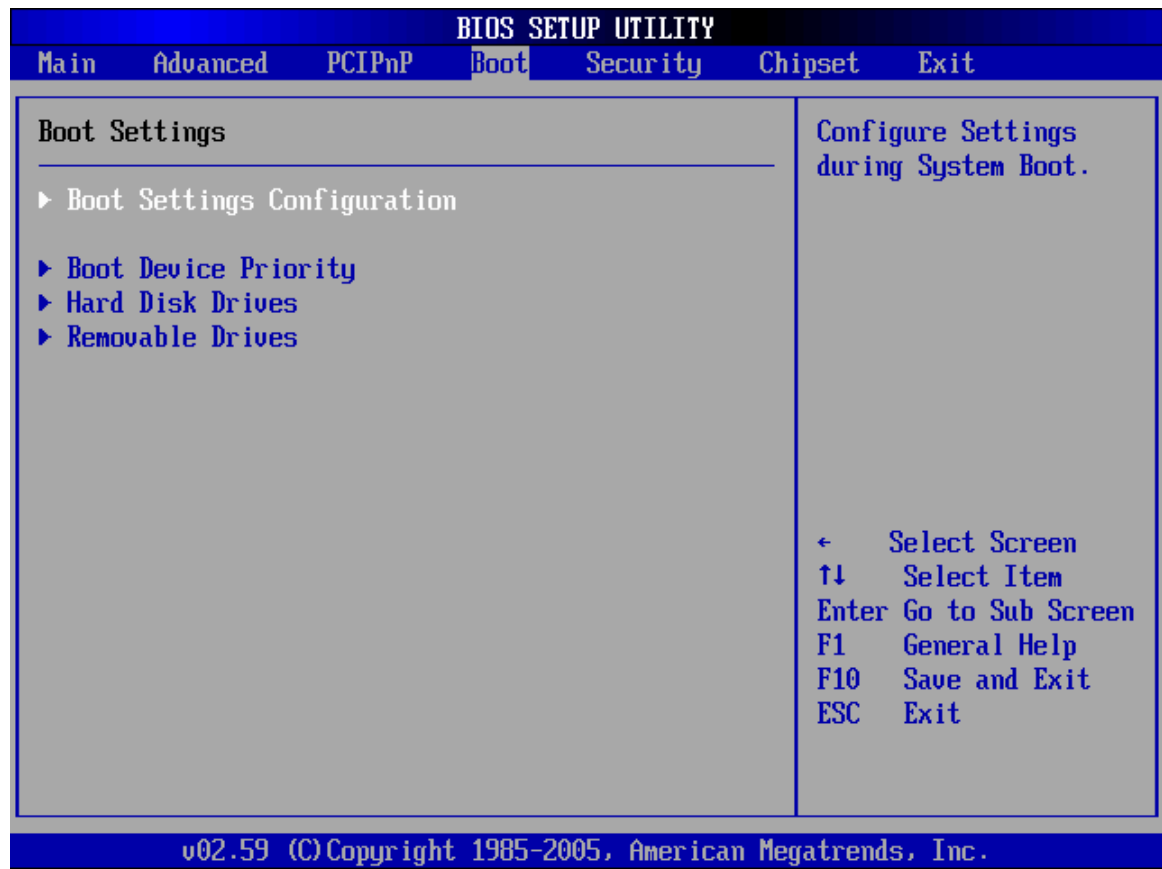

BIOS Menu 17: Boot

6.5.1 Boot Settings Configuration

Use the **Boot Settings Configuration** menu (**BIOS Menu 18**) to configure advanced system boot options.

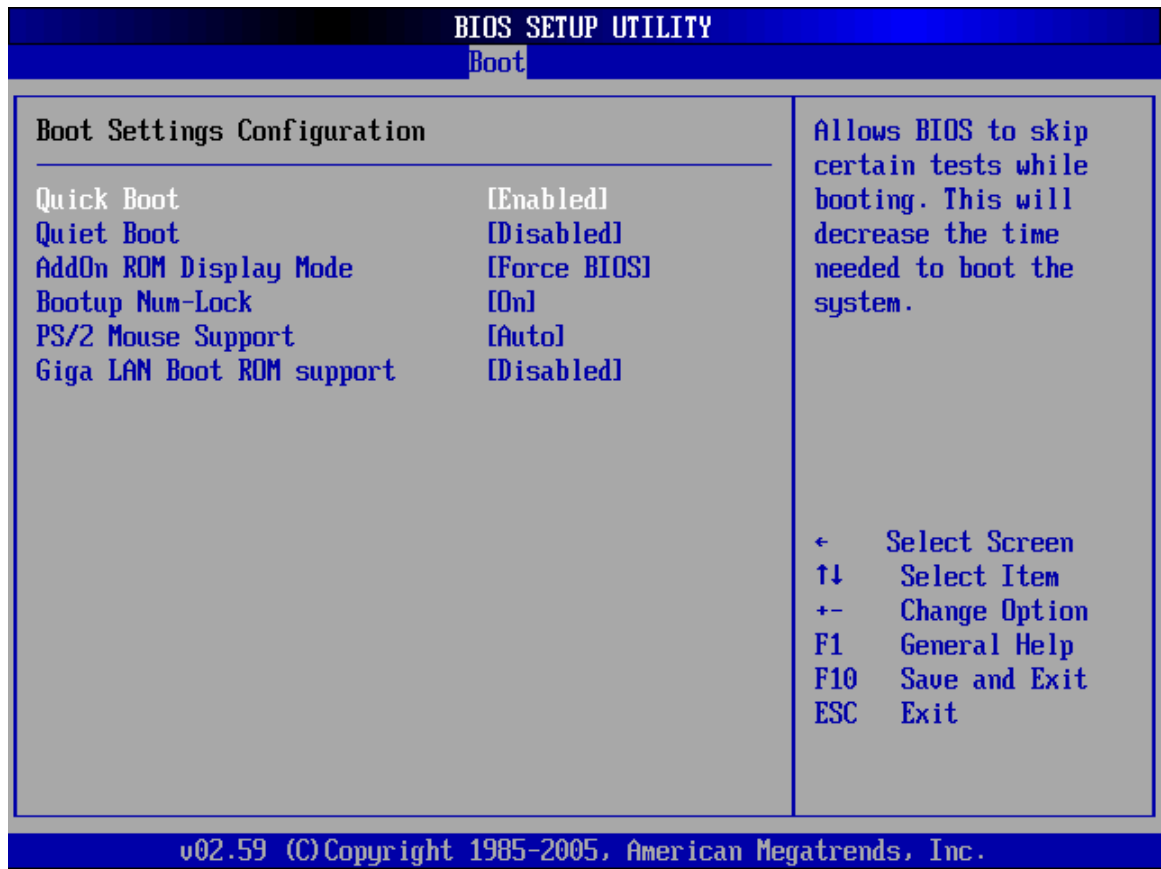

BIOS Menu 18: Boot Settings Configuration

→ Quick Boot [Enabled]

Use the **Quick Boot** BIOS option to make the computer speed up the boot process.

- **Disabled** No POST procedures are skipped
- **Enabled** DEFAULT Some POST procedures are skipped to decrease the system boot time

WSB-9452 PICMG 1.0 CPU Card

→ Quiet Boot [Disabled]

Use the **Quiet Boot** BIOS option to select the screen display when the system boots.

- **Disabled** DEFAULT Normal POST messages displayed
- **Enabled** OEM Logo displayed instead of POST messages

→ AddOn ROM Display Mode [Force BIOS]

Use the **AddOn ROM Display Mode** option to allow add-on ROM (read-only memory) messages to be displayed.

- **Force BIOS** DEFAULT The system forces third party BIOS to display during system boot.
- **Keep Current** The system displays normal information during system boot.

→ Bootup Num-Lock [On]

Use the **Bootup Num-Lock** BIOS option to specify if the number lock setting must be modified during boot up.

- **Off** Does not enable the keyboard Number Lock automatically. To use the 10-keys on the keyboard, press the Number Lock key located on the upper left-hand corner of the 10-key pad. The Number Lock LED on the keyboard lights up when the Number Lock is engaged.

- **On** DEFAULT Allows the Number Lock on the keyboard to be enabled automatically when the computer system boots up. This allows the immediate use of the 10-key numeric keypad located on the right side of the keyboard. To confirm this, the Number Lock LED light on the keyboard is lit.

→ **PS/2 Mouse Support [Auto]**

Use the **PS/2 Mouse Support** option adjusts PS/2 mouse support capabilities.

- **Disabled** PS/2 mouse support is disabled and prevented from using system resources.
- **Enabled** Allows the system to use a PS/2 mouse.
- **Auto** DEFAULT The system auto-adjusts PS/2 mouse support.

→ **Giga LAN Boot ROM Support [Disabled]**

The **Giga LAN Boot ROM Support** option enables the system to be booted from a remote system.

- **Disabled** DEFAULT Cannot be booted from a remote system through the LAN
- **Enabled** Can be booted from a remote system through the LAN

6.5.2 Boot Device Priority

Use the **Boot Device Priority** menu (**BIOS Menu 19**) to specify the boot sequence from the available devices. Possible boot devices may include:

- 1st FLOPPY DRIVE
- HDD
- CD/DVD

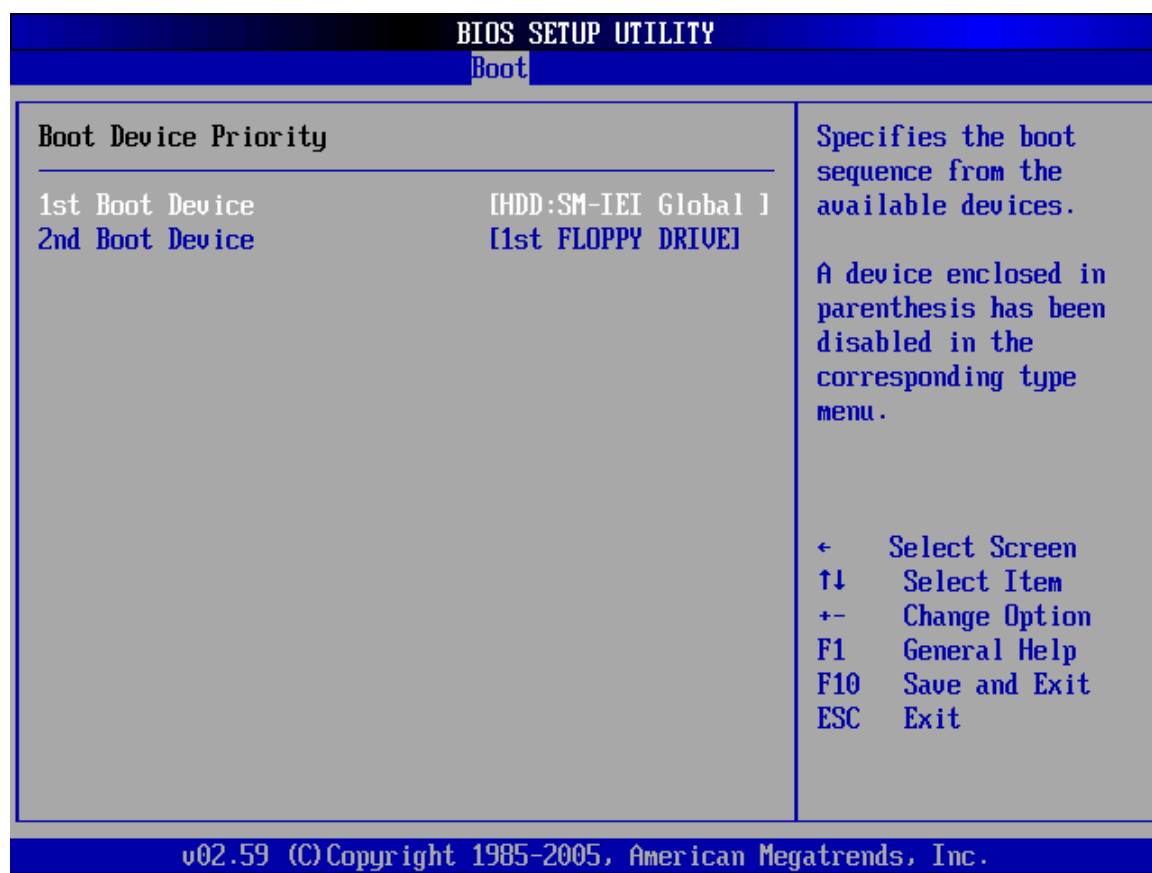

BIOS Menu 19: Boot Device Priority Settings

6.5.3 Hard Disk Drives

The **Hard Disk Drives** menu (**BIOS Menu 20**) specifies the boot sequence of the available HDDs. When the menu is opened, the HDDs connected to the system are listed as shown below:

- 1st Drive [HDD: PM-(part number)]
- 2nd Drive [HDD: PS-(part number)]
- 3rd Drive [HDD: SM-(part number)]
- 4th Drive [HDD: SM-(part number)]

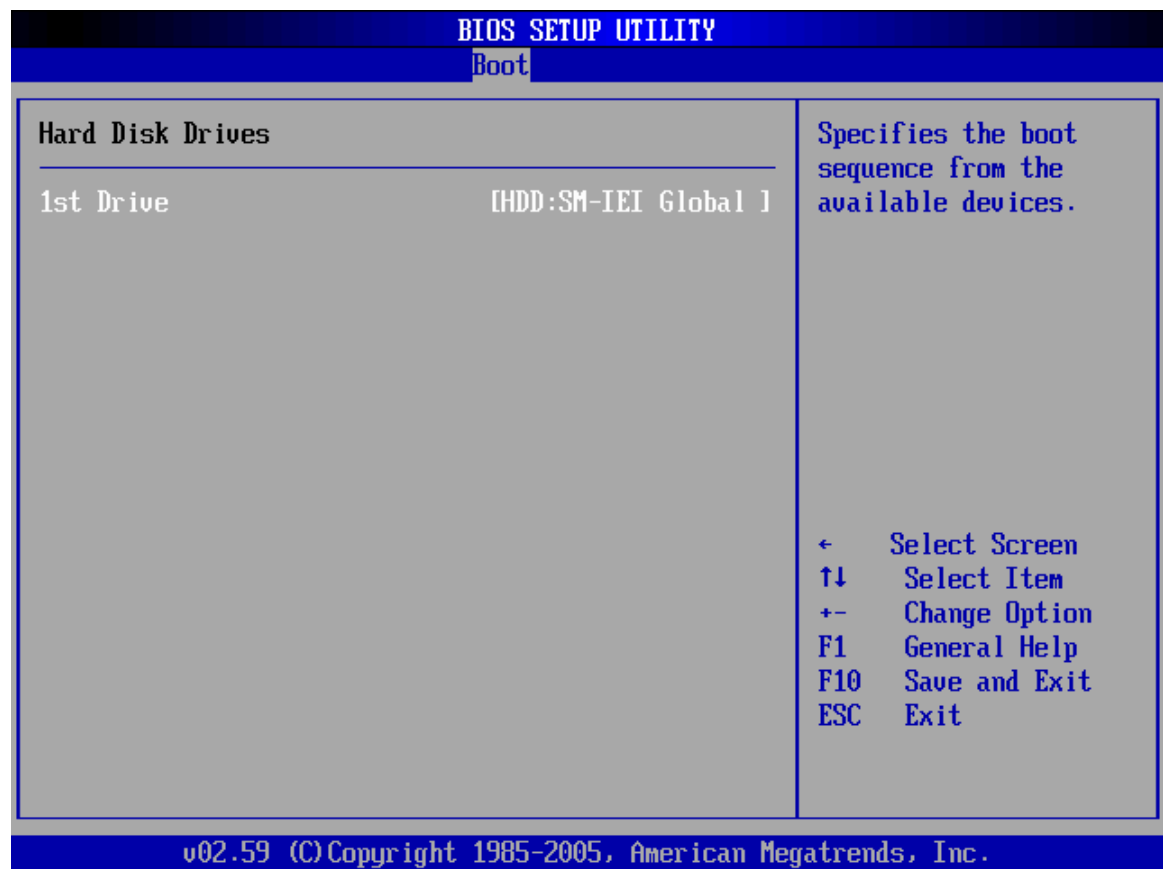

BIOS Menu 20: Hard Disk Drives

**NOTE:**

Only the drives connected to the system are shown. For example, if only two HDDs are connected only “**1st Drive**” and “**2nd Drive**” are listed.

The boot sequence from the available devices is selected. If the “**1st Drive**” option is selected a list of available HDDs is shown. Select the first HDD system boots from. If the “**1st Drive**” is not used for booting this option may be disabled.

6.5.4 Removable Drives

Use the **Removable Drives** menu (**BIOS Menu 21**) to specify the boot sequence of the available FDDs. When the menu is opened, the FDDs connected to the system are listed as shown below:

- 1st Drive

**NOTE:**

Only the drives connected to the system are shown. For example, if only one FDD is connected only “**1st Drive**” is listed.

The boot sequence from the available devices is selected. If the “**1st Drive**” option is selected a list of available removable drives is shown. Select the first drive the system boots from. If the “**1st Drive**” is not used for booting this option may be disabled.

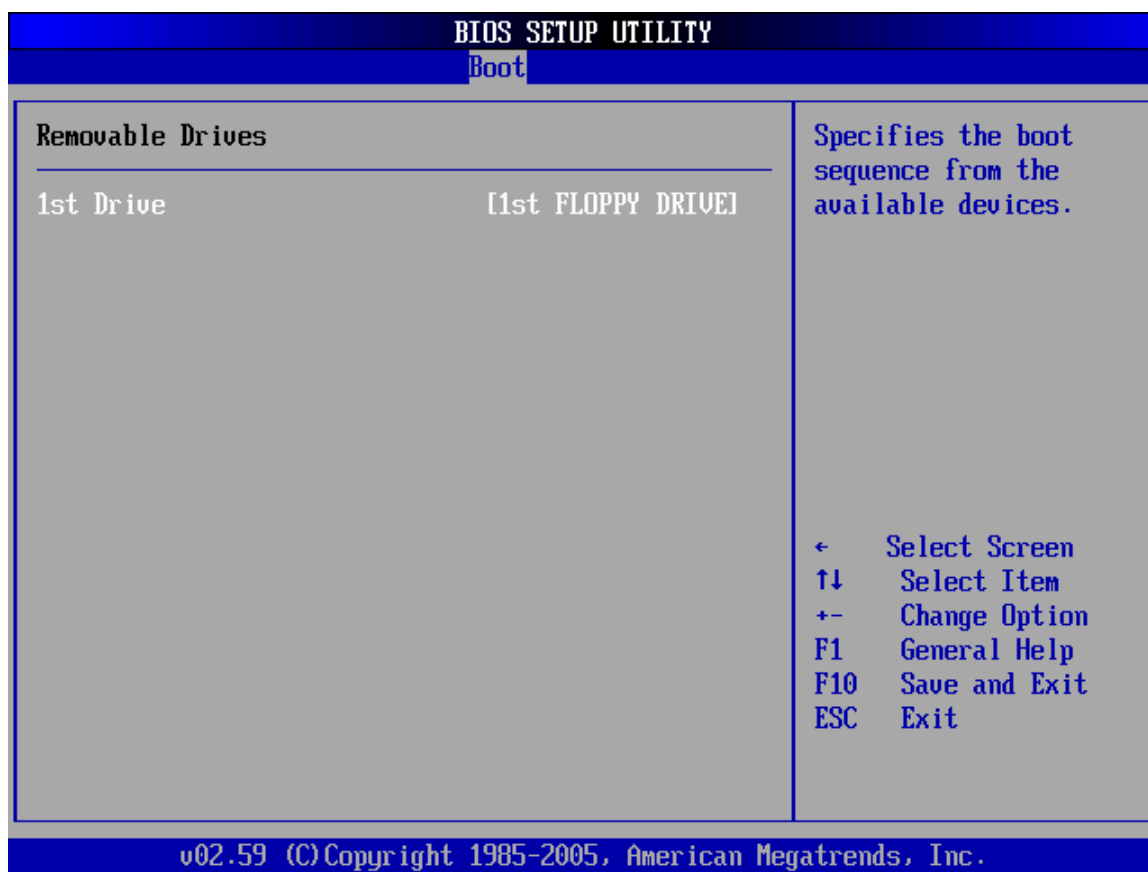

BIOS Menu 21: Removable Drives

6.6 Security

Use the **Security** menu (**BIOS Menu 22**) to set system and user passwords.

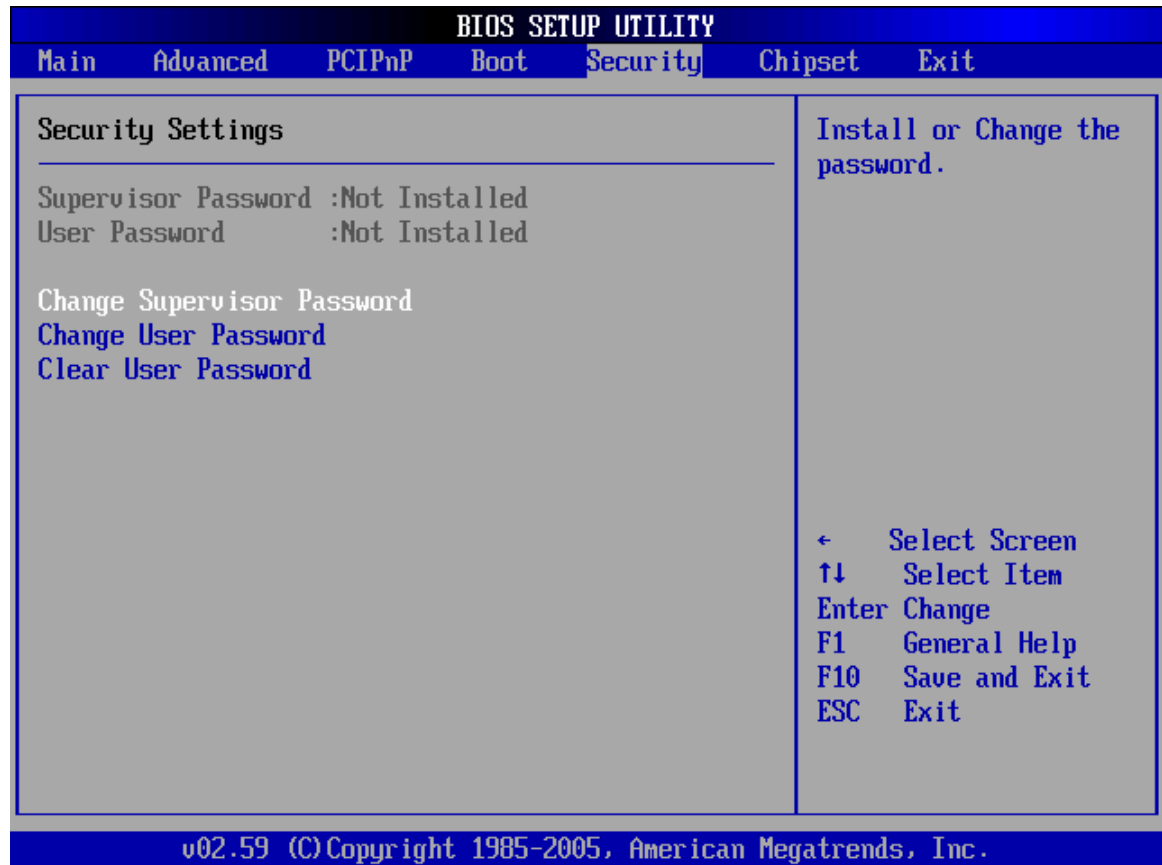

BIOS Menu 22: Security

→ Change Supervisor Password

Use the **Change Supervisor Password** to set or change a supervisor password. The default for this option is **Not Installed**. If a supervisor password must be installed, select this field and enter the password. After the password has been added, **Install** appears next to **Change Supervisor Password**.



→ **Change User Password**

Use the **Change User Password** to set or change a user password. The default for this option is **Not Installed**. If a user password must be installed, select this field and enter the password. After the password has been added, **Install** appears next to **Change User Password**.

6.7 Chipset

Use the **Chipset** menu (**BIOS Menu 23**) to access the Northbridge and Southbridge configuration menus.



WARNING:

Setting the wrong values for the Chipset BIOS selections in the Chipset BIOS menu may cause the system to malfunction.

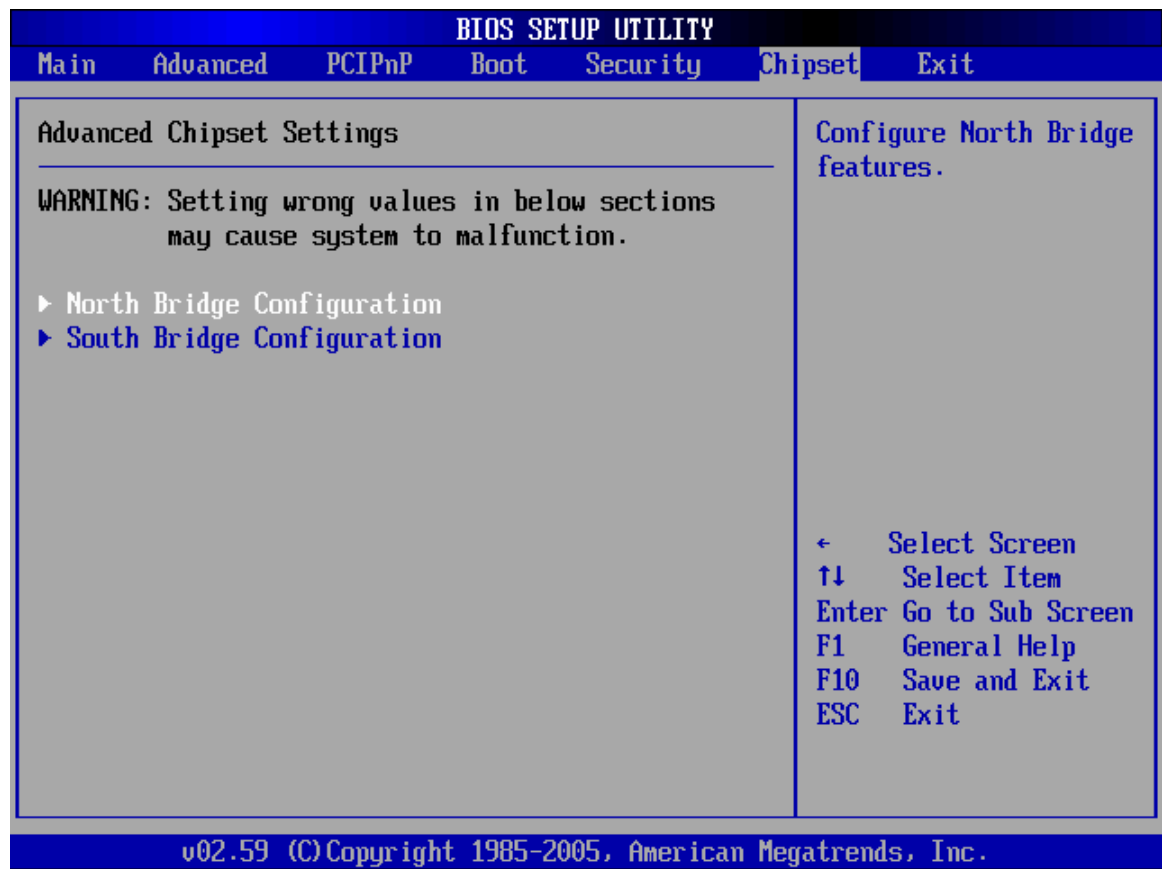

BIOS Menu 23: Chipset

6.7.1 Northbridge Configuration

Use the **Northbridge Configuration** menu (**BIOS Menu 24**) to configure the Northbridge chipset.



BIOS Menu 24: Northbridge Chipset Configuration

→ DRAM Frequency [Auto]

Use the **DRAM Frequency** option to specify the DRAM frequency or allow the system to automatically detect the DRAM frequency.

- **Auto** DEFAULT Automatically selects the DRAM frequency
- **400MHz** Sets the DRAM frequency to 400MHz

WSB-9452 PICMG 1.0 CPU Card

- **533MHz** Sets the DRAM frequency to 533MHz
- **667MHz** Sets the DRAM frequency to 667MHz

→ **Configure DRAM Timing by SPD [Enabled]**

Use the **Configure DRAM Timing by SPD** option to determine if the system uses the SPD (Serial Presence Detect) EEPROM to configure the DRAM timing. The SPD EEPROM contains all necessary DIMM specifications including the speed of the individual components such as CAS and bank cycle time as well as valid settings for the module and the manufacturer's code. The SPD enables the BIOS to read the spec sheet of the DIMMs on boot-up and then adjust the memory timing parameters accordingly.

- **Disabled** DRAM timing parameters are manually set using the
DRAM sub-items
- **Enabled** DEFAULT DRAM timing parameter are set according to the
DRAM Serial Presence Detect (SPD)

If the **Configure DRAM Timing by SPD** option is disabled, the following configuration options appear.

- DRAM CAS# Latency [5]
- DRAM RAS# to CAS# Delay [6 DRAM Clocks]
- DRAM RAS# Precharge [6 DRAM Clocks]
- DRAM RAS# Activate to Precha [15 DRAM Clocks]

→ **Memory Hole [Disabled]**

Use the **Memory Hole** option to reserve memory space between 15MB and 16MB for ISA expansion cards that require a specified area of memory to work properly. If an older ISA expansion card is used, please refer to the documentation that came with the card to see if it is necessary to reserve the space.

- **Disabled** DEFAULT Memory is not reserved for ISA expansion cards
- **15MB – 16MB** Between 15MB and 16MB of memory is reserved for ISA expansion cards

→ **Boots Graphics Adapter Priority [IGD]**

Use the **Boots Graphics Adapter Priority** option to select the graphics controller used as the primary boot device. Select either an integrated graphics controller (IGD) or a combination of PCI graphics controller, a PCI express (PEG) controller or an IGD. Configuration options are listed below:

- IGD Default
- PCI/IGD
- PCI/PEG
- PEG/IGD
- PEG/PCI

→ **Internal Graphics Mode Select [Enabled, 8MB]**

Use the **Internal Graphic Mode Select** option to specify the amount of system memory that can be used by the Internal graphics device.

- **Disable**
- **Enable, 1MB** 1MB of memory used by internal graphics device
- **Enable, 8MB** DEFAULT 8MB of memory used by internal graphics device

6.7.1.1 Video Function Configuration

Use the **Video Function Configuration** menu (**BIOS Menu 25**) to configure the video device connected to the system.



BIOS Menu 25: Video Function Configuration

→ DVMT Mode Select [DVMT Mode]

Use the **DVMT Mode Select** option to select the Intel Dynamic Video Memory Technology (DVMT) operating mode.

- **Fixed Mode** A fixed portion of graphics memory is reserved as graphics memory.
- **DVMT Mode** DEFAULT Graphics memory is dynamically allocated according to the system and graphics needs.
- **Combo Mode** A fixed portion of graphics memory is reserved as graphics memory. If more memory is needed, graphics memory is dynamically allocated according to the system and graphics needs.

→ **DVMT/FIXED Memory [128MB]**

Use the **DVMT/FIXED Memory** option to specify the maximum amount of memory that can be allocated as graphics memory. This option can only be configured for if **DVMT Mode** or **Fixed Mode** is selected in the **DVMT Mode Select** option. If **Combo Mode** is selected, the maximum amount of graphics memory is 128MB. Configuration options are listed below.

- 64MB
- 128MB DEFAULT
- Maximum DVMT

→ **Boot Display Device [CRT on Port 0]**

Use the **Boot Display Device** option to select the display device used by the system when it boots. Configuration option is listed below.

- CRT on Port 0 DEFAULT
- CRT and DFP
- CRT and LCD

WSB-9452 PICMG 1.0 CPU Card

→ Flat Panel Type [640*480]

Use the **Flat Panel Type** option to select the type of flat panel connected to the system.

Configuration options are listed below.

- 640*480
- 800*600
- 1024*768 (18 bits) DEFAULT
- 1280*1024 (36bits)
- 1400*1050 (36bits)
- 1600*1200 (36bits)
- 1280*768
- 1680*1050 (36bits)
- 1920*1200 (36bits)
- 1024*768 (48 bits)
- 1440 x 900 (36 bits)
- 1440 x 900 (48 bits)
- 1280 x 800 (18 bits)
- 1260 x 600 (18 bits)
- 2048 x 1536 (36 bits)

→ Local Flat Panel Scaling [Auto]

Use the **Local Flat Panel Scaling** option to select the method of scaling for the flat panel screen attached to the system.

- **Auto** DEFAULT Scaling is automatic
- **Forced Scaling** Scaling is forced
- **Disabled** Scaling is disabled

→ TV Connector [Auto]

Use the **TV Connector** option to select the connector that is used to connect the system to the television. The configuration option is listed below.

- Auto DEFAULT
- Composite
- Component
- Composite & RGB
- S-Video
- SCART Composite
- SCART Compos. & RGB
- SCART Compos. & S-Vdo
- SMPTE253 Compon. RGB

➔ **HDTV Output [Auto]**

Use the **HDTV Output** option to select the number of vertical lines in each frame, the method the HDTV connected to the system scans and the frequency of the frames.

Two scanning types can be selected: interlaced (i) or progressive (p). Interlaced scanning divides and presents each video frame as two fields. The first field presents the odd lines and the second field presents the even lines. In progressive scanning, the image is refreshed from top to bottom, one line after the other.

Configuration options are listed below:

Option	Scan Type	Vertical Lines	Frame Frequency
Auto	Auto	Auto	Auto
480i60	Interlaced	240 per field (480 per frame)	60 frames per second
480p60	Progressive	480 per frame	60 frames per second
576i50	Interlaced	283 per field (576 per frame)	50 frames per second
576p50	Progressive	576 per frame	50 frames per second
720p60	Progressive	720 per frame	60 frames per second
1080i50	Interlaced	540 per field (1080 per frame)	50 frames per second
1080i60	Interlaced	540 per field (1080 per frame)	60 frames per second

WSB-9452 PICMG 1.0 CPU Card

1080p24	Progressive	1080 per frame	24 frames per second
1080p25	Progressive	1080 per frame	25 frames per second
1080p30	Progressive	1080 per frame	30 frames per second
1080p50	Progressive	1080 per frame	50 frames per second
1080p60	Progressive	1080 per frame	60 frames per second

→ TV Standard [VBIOS-Default]

Use the **TV Standard** option to select the standard of the television connected to the system. The configuration options are listed below.

- VBIOS-Default DEFAULT
- NTSC
- PAL
- SECAM
- SMPTE240M
- ITU-R television
- SMPTE295M
- SMPTE296M
- ETA-770.2
- ETA-770.3

6.7.2 Southbridge Configuration

The **Southbridge Configuration** menu (**BIOS Menu 26**) the Southbridge chipset to be configured.

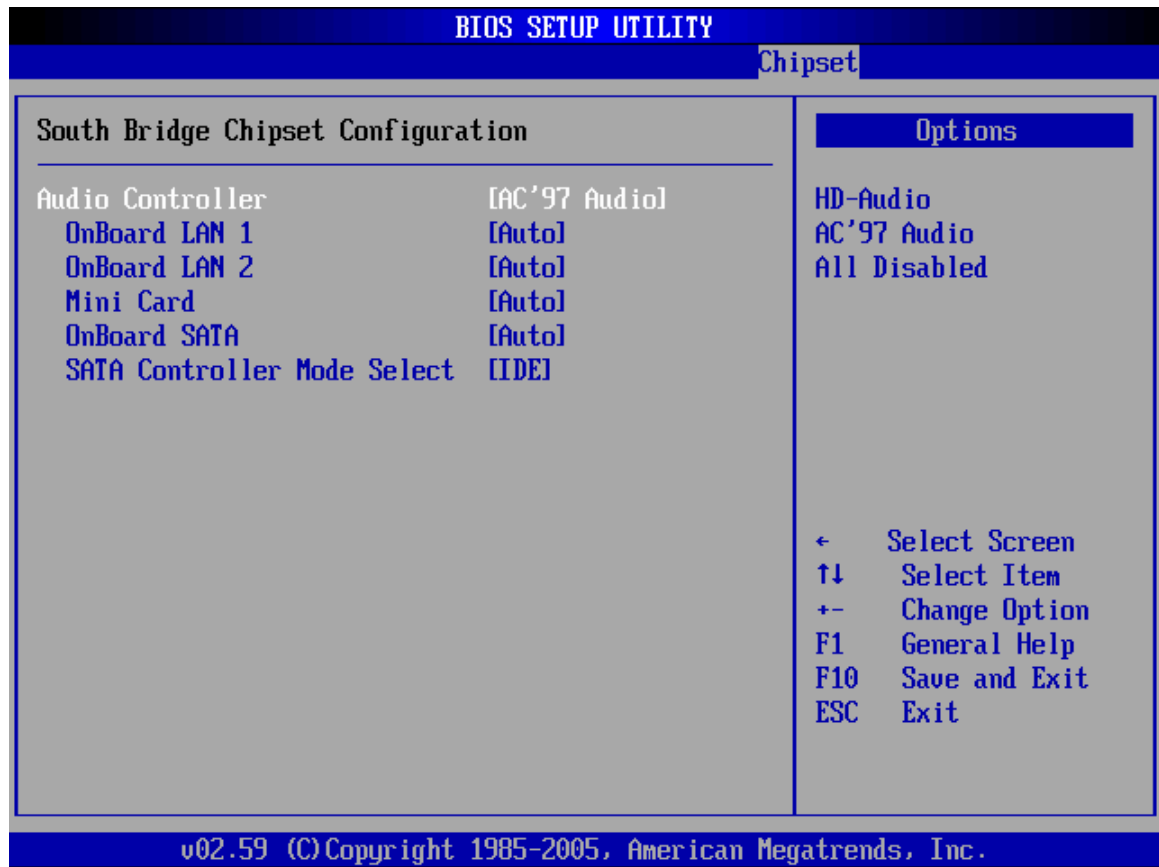

BIOS Menu 26:Southbridge Chipset Configuration

WSB-9452 PICMG 1.0 CPU Card

→ Audio Controller [AC'97 Audio]

The **Audio Controller** option allows selection of the audio controller to use.

- **Azalia** DEFAULT The Intel® High Definition Audio controller is enabled
- **AC'97 Audio** The on-board AC'97 controller is enabled
- **All Disabled** All audio controllers are disabled

→ OnBoard LAN1 [Auto]

The **OnBoard LAN1** option enables or disables the on-board LAN1.

- **Auto** DEFAULT The on-board LAN1 controller is automatically detected and enabled
- **Enabled** The on-board LAN1 controller is manually enabled
- **Disabled** The on-board LAN1 controller is manually disabled

→ On-board LAN2 [Auto]

The **On-board LAN2** option enables or disables the on-board LAN2.

- **Auto** DEFAULT The on-board LAN2 controller is automatically detected and enabled
- **Enabled** The on-board LAN2 controller is manually enabled
- **Disabled** The on-board LAN2 controller is manually disabled

→ Mini Card [Auto]

The **Mini Card** option enables or disables the PCI Express Mini Card.

- **Auto** DEFAULT The PCI Express Mini Card is automatically detected and enabled
- **Enabled** The PCI Express Mini Card is manually enabled
- **Disabled** The PCI Express Mini Card is manually disabled

→ **SATA Controller**

Use the **SATA Controller** option to enable or disable the onboard SATA controller.

- **Auto** DEFAULT The onboard SATA controller is automatically detected and enabled
- **Enabled** The SATA controller is manually enabled
- **Disabled** The SATA controller is manually disabled

→ **SATA Controller Mode Select**

Use the **SATA Controller Mode Select** option to set the mode of the JMB363 SATA controller. If the RAID function is going to be used this option must be set to **RAID** mode.

- **Disabled** DEFAULT The onboard PCI SATA controller is disabled
- **IDE** The SATA controller is set as an IDE device
- **RAID** The SATA controller is set as a RAID device
- **AHCI** The SATA controller is set as an Advanced Host Controller Interface (AHCI)

6.8 Exit

Use the **Exit** menu (**BIOS Menu 27**) to load default BIOS values, optimal failsafe values and to save configuration changes.

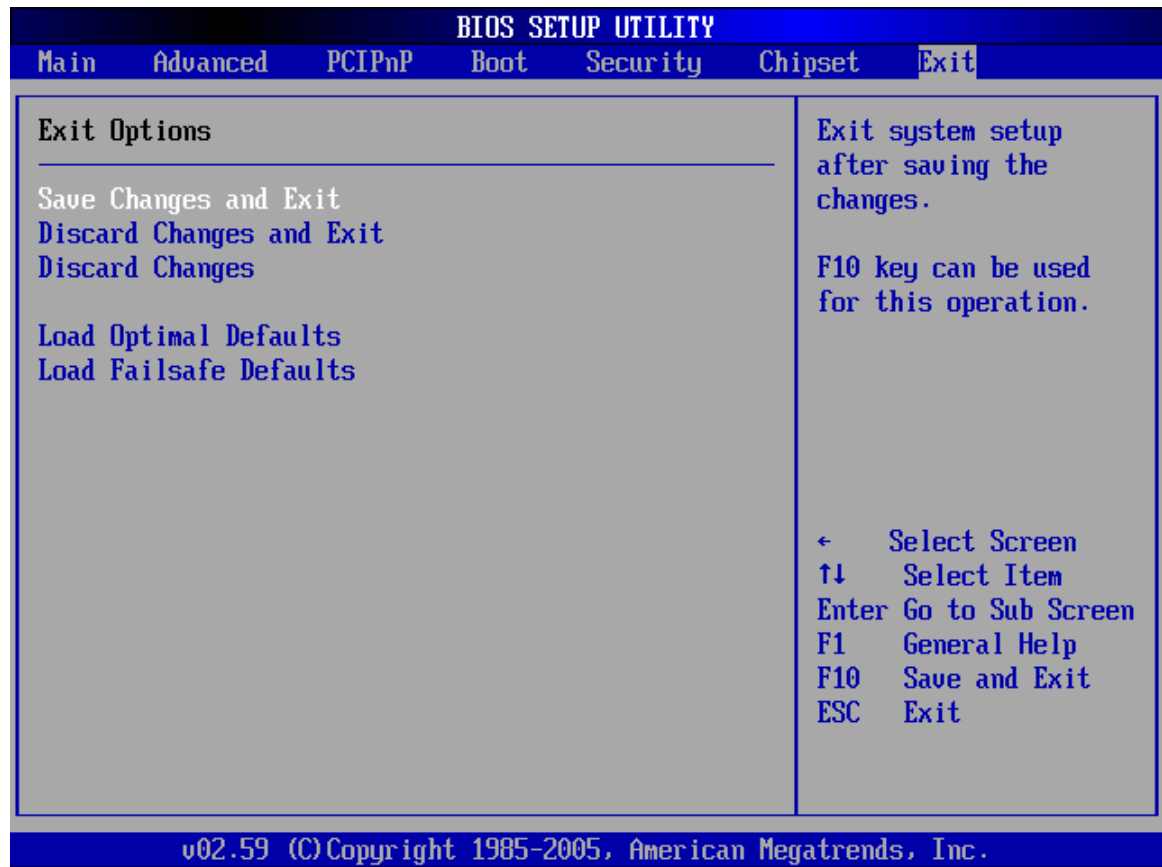

BIOS Menu 27:Exit

→ Save Changes and Exit

Use the **Save Changes and Exit** option to save the changes made to the BIOS options and to exit the BIOS configuration setup program.

→ Discard Changes and Exit

Use the **Discard Changes and Exit** option to exit the BIOS configuration setup program without saving the changes made to the system.

→ **Discard Changes**

Use the **Discard Changes** option to discard the changes and remain in the BIOS configuration setup program.

→ **Load Optimal Defaults**

Use the **Load Optimal Defaults** option to load the optimal default values for each of the parameters on the Setup menus. **F9 key can be used for this operation.**

→ **Load Failsafe Defaults**

Use the **Load Failsafe Defaults** option to load failsafe default values for each of the parameters on the Setup menus. **F8 key can be used for this operation.**

Chapter

7

Software drivers

7.1 Available Software Drivers



NOTE:

The content of the CD may vary throughout the life cycle of the product and is subject to change without prior notice. Visit the IEI website or contact technical support for the latest updates.

The WSB-9452 motherboard has the following software drivers:

- Intel® Chipset Driver Installation
- VGA Utilities Driver
- LAN Driver (for GbE LAN) Installation
- Audio Driver (ALC655 / ALC883) Installation
- SATA Driver Installation

All drivers can be found on the CD that came with the motherboard. To install the drivers please follow the instructions in the sections below.

7.2 Chipset Driver Installation

To install the chipset driver, please follow the steps below:

- Step 1:** Insert the CD into the system that contains the WSB-9452 board. Open the **1-INF** directory and locate the icon for the **infinst_autol.exe** installation file. Once located, use the mouse to double click the icon.

WSB-9452 PICMG 1.0 CPU Card

Step 2: The “InstallShield Wizard Preparation Screen” in **Figure 7-1** appears.

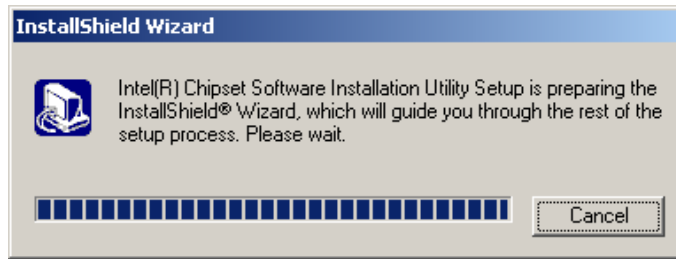

Figure 7-1: InstallShield Wizard Preparation Screen

Step 3: The “Welcome” window in **Figure 7-2** appears next.

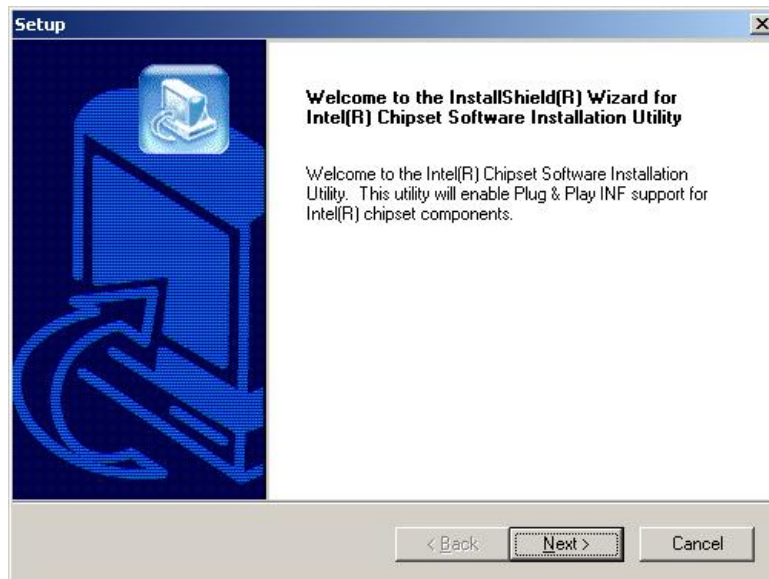

Figure 7-2: Welcome Screen

Step 4: Click “NEXT” and the license agreement shown in **Figure 7-3** appears.

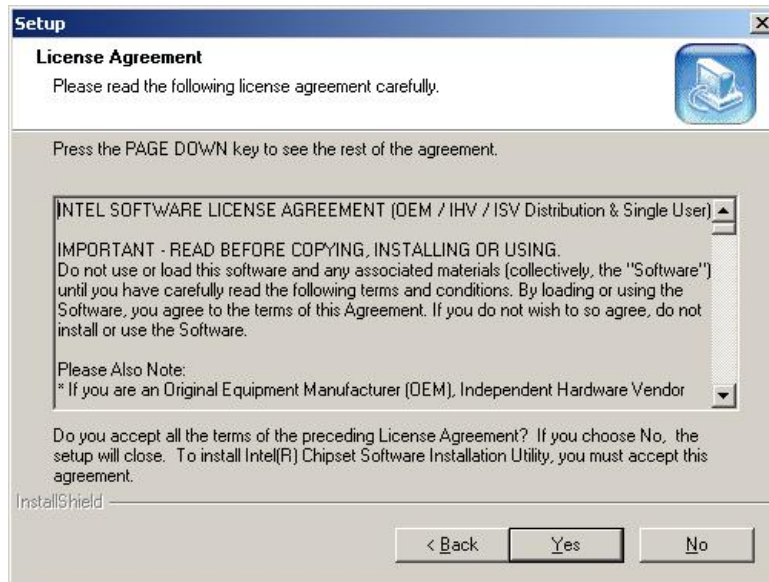

Figure 7-3: License Agreement

WSB-9452 PICMG 1.0 CPU Card

Step 5: Agree to the license terms by clicking “YES”. The “Readme” in **Figure 7-4** appears.

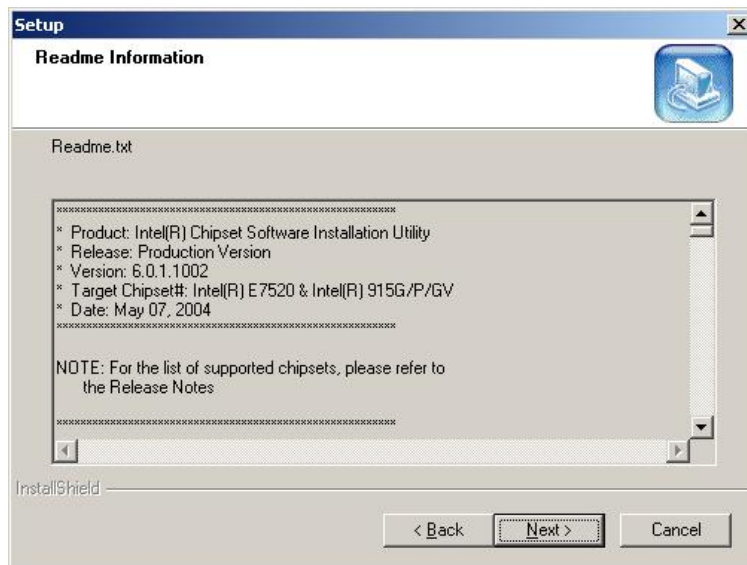

Figure 7-4: Readme Information

Step 6: Click “YES”. The driver is installed on the computer. After the installation is complete, the installation complete screen shown in **Figure 7-5** appears. Select the preferred option and click “**FINISH**” to complete the installation process.



Figure 7-5: Restart the Computer

7.3 VGA Driver

To install the VGA driver, please follow the steps below:

Step 1: Insert the Utility CD that came with the motherboard into the system CD drive.

Step 2: Open the **X:\2-VGAWIN2K_XP** directory (where **X:** is the system CD drive) and double-click the **win2k_xp1420.exe** installation file.

Step 3: The Starting Install Shield Wizard appears (**Figure 7-6**).

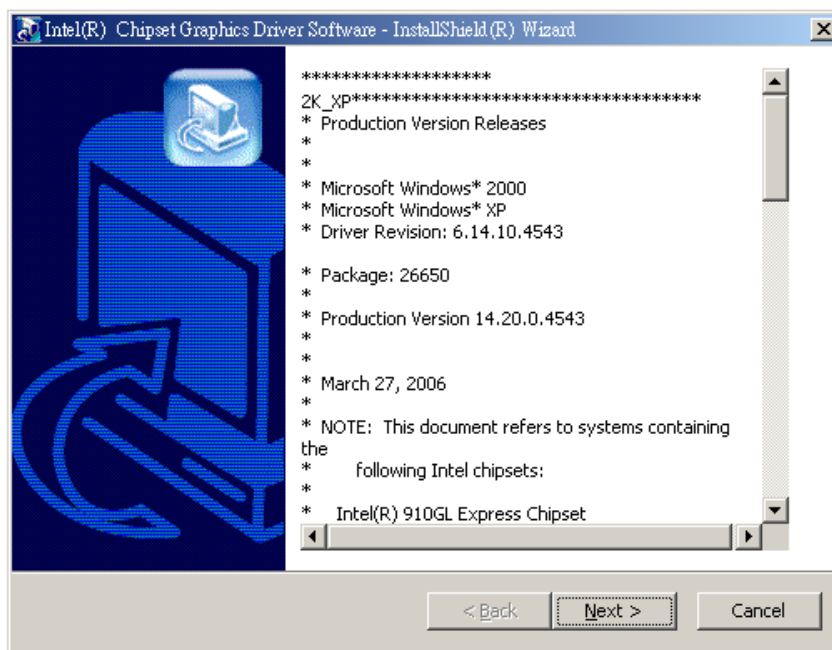

Figure 7-6: Starting Install Shield Wizard Screen

Step 4: The Preparing Setup window appears next (Figure 7-7).

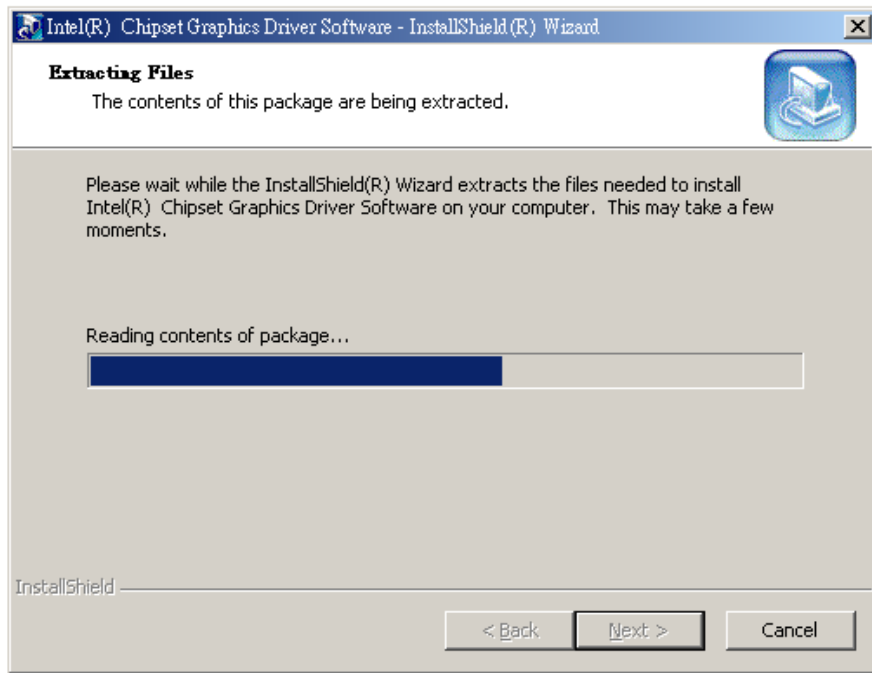

Figure 7-7: Preparing Setup Screen

WSB-9452 PICMG 1.0 CPU Card

Step 5: A Welcome screen shown in **Figure 7-8** appears. Click **NEXT** to continue the installation.

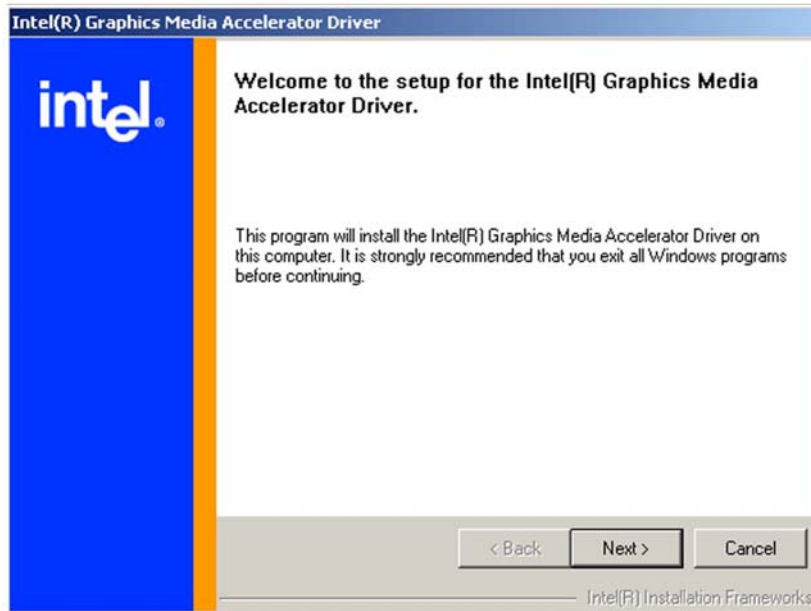

Figure 7-8: VGA Driver Installation Welcome Screen

Step 6: A license agreement shown in **Figure 7-9** appears. Read through the license agreement.

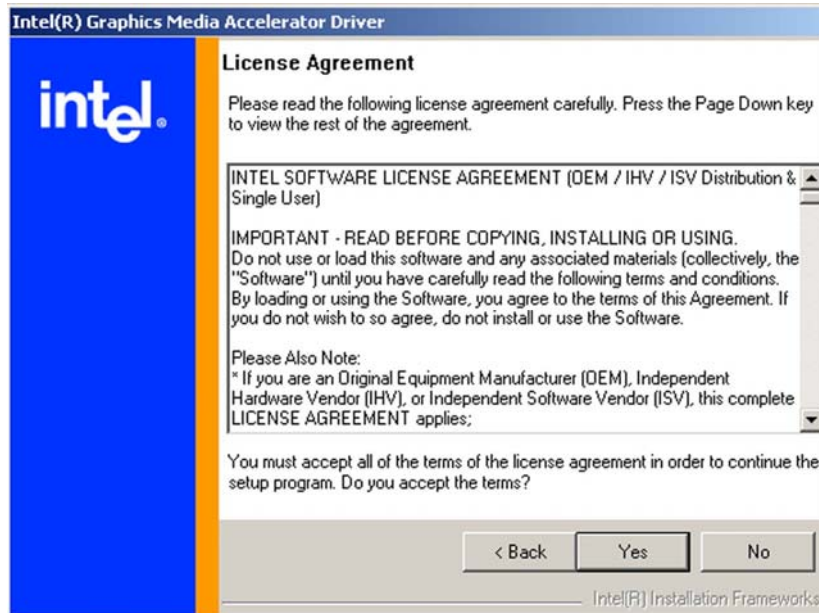

Figure 7-9: VGA Driver License Agreement

Step 7: Accept the terms and conditions stipulated in the license agreement by clicking the “**YES**” button (**Figure 7-9**). The installation notice shown in **Figure 7-10** appears.



Figure 7-10: VGA Driver Installing Notice

WSB-9452 PICMG 1.0 CPU Card

Step 8: After the driver installation process is complete, a confirmation screen shown in **Figure 7-11** appears.

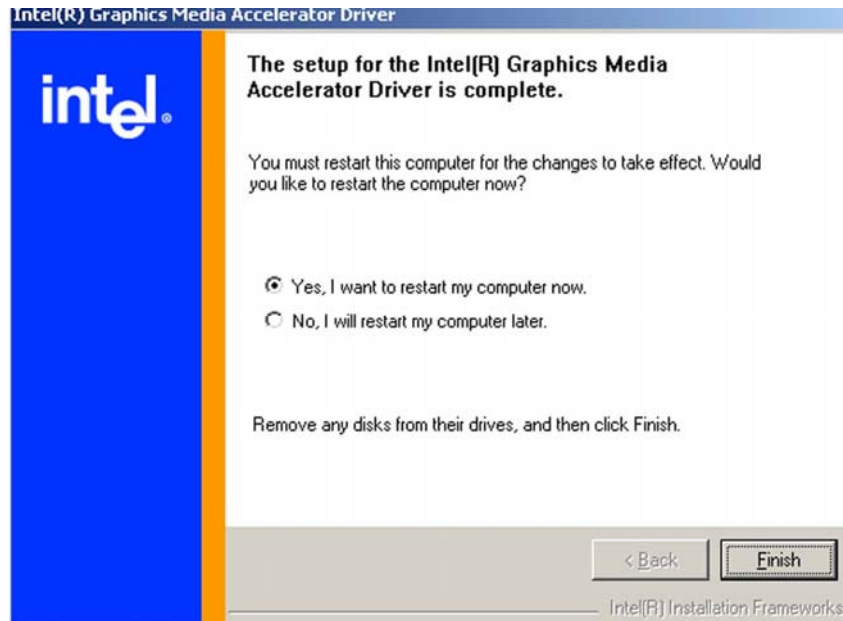

Figure 7-11: VGA Driver Installation Complete

Step 9: The confirmation screen shown in **Figure 7-11** allows user to restart the computer immediately after the installation is complete or to restart the computer later. For the settings to take effect the computer must be restarted. Once decided when to restart the computer, click the “**FINISH**” button.

7.4 Broadcom LAN Driver (for GbE LAN) Installation

To install the Broadcom LAN driver, please follow the steps below.

Step 1: Open Windows Control Panel (Figure 7-12).

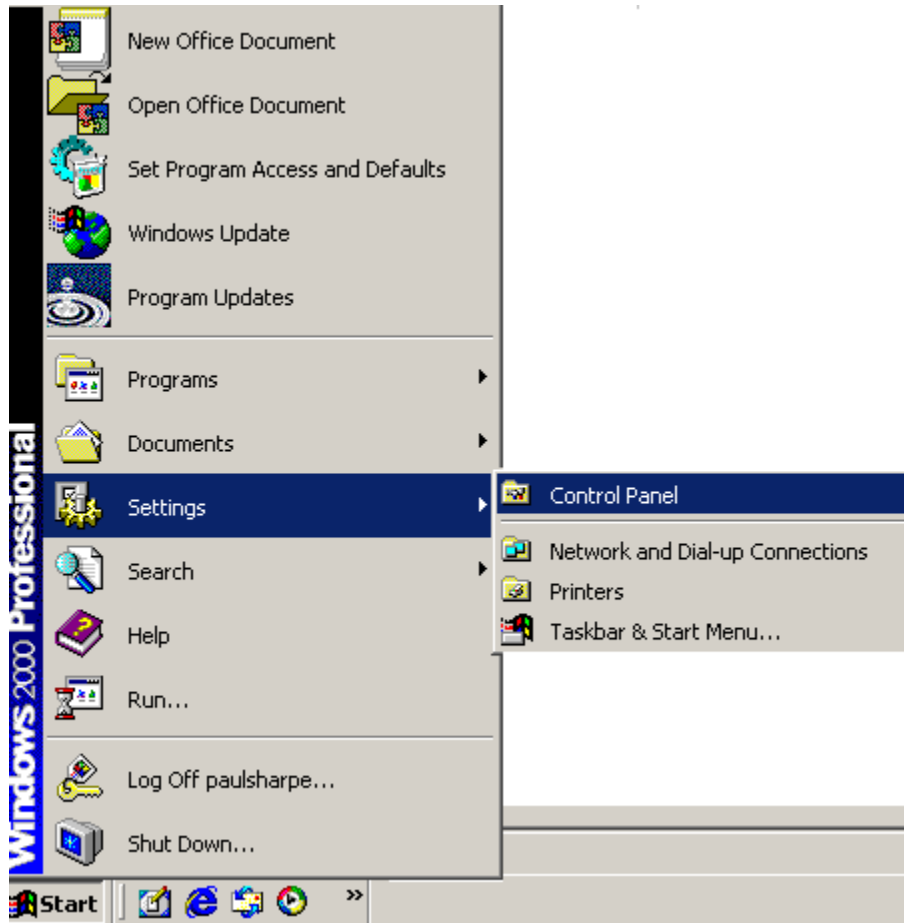

Figure 7-12: Access Windows Control Panel

WSB-9452 PICMG 1.0 CPU Card

Step 2: Double click the **System** icon (Figure 7-13).

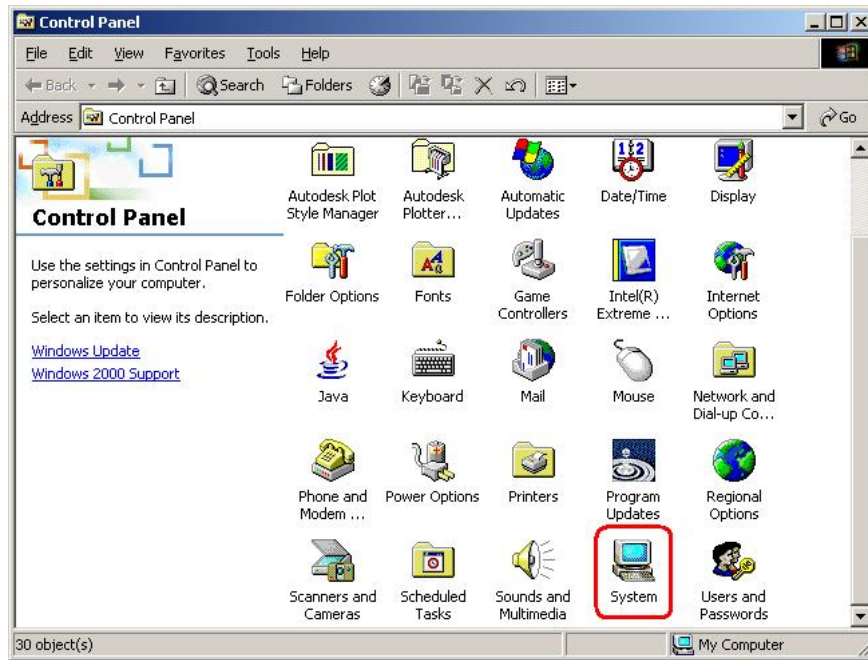

Figure 7-13: Double Click the System Icon

Step 3: Click the **Hardware Tab**, then double click **Device Manager** (Figure 7-14).

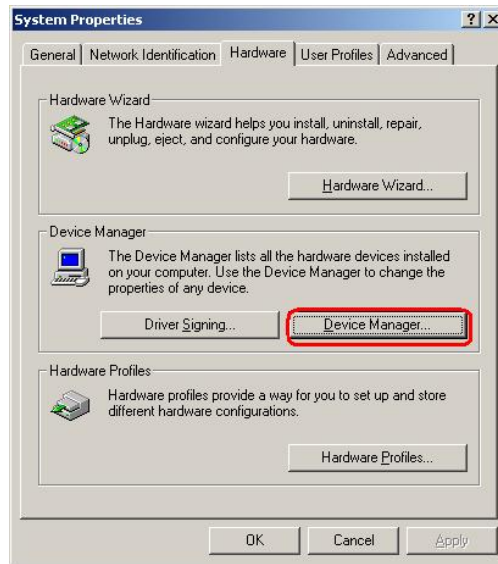

Figure 7-14: Double Click the Device Manager Tab

Step 4: A list of system hardware devices appears (Figure 7-15).

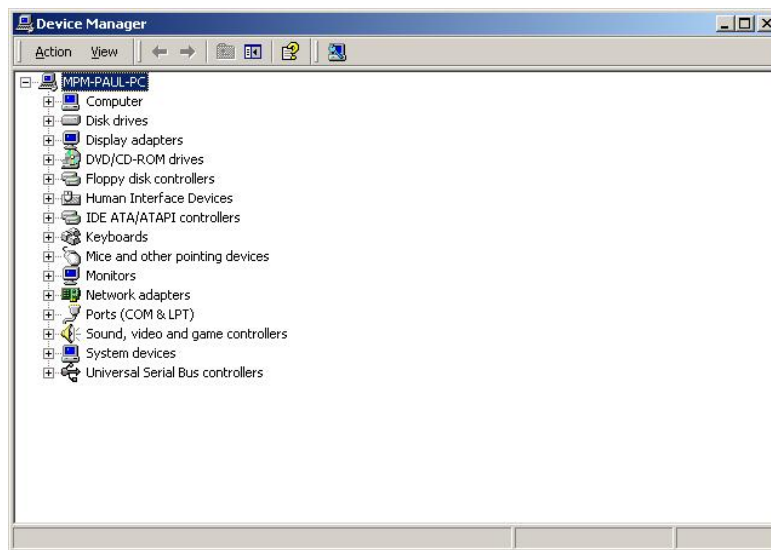

Figure 7-15: Device Manager List

Step 5: Double click the listed device that has question marks next to it. (This means Windows does not recognize the device).

WSB-9452 PICMG 1.0 CPU Card

Step 6: The **Device Driver Wizard** appears (Figure 7-16). Click **NEXT** to continue.



Figure 7-16: Search for Suitable Driver

Step 7: Select “Specify a Location” in the **Locate Driver Files** window (Figure 7-17).

Click **NEXT** to continue.

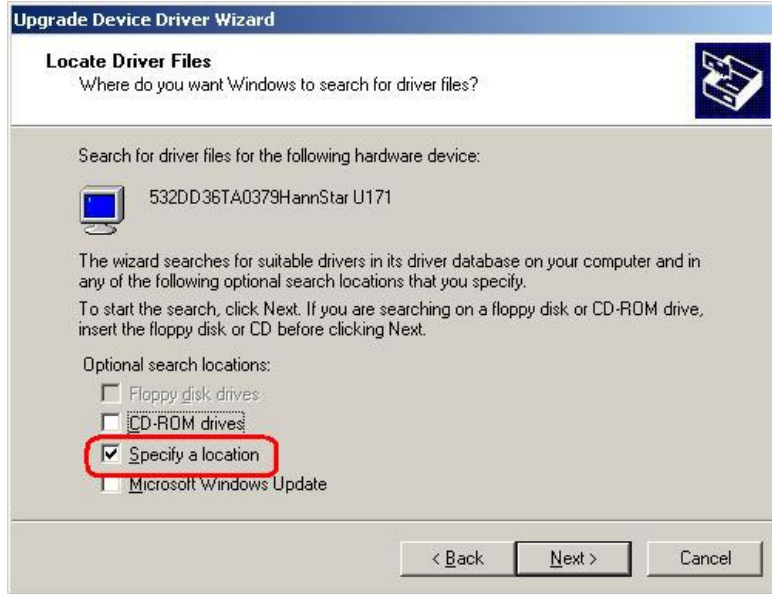

Figure 7-17: Locate Driver Files

WSB-9452 PICMG 1.0 CPU Card

Step 8: Select the proper OS folder under the “X:\3-LAN\E:\3-LAN\BoadCom BCM5787” directory (**Figure 7-18**) in the location browsing window, where “X:\” is the system CD drive.

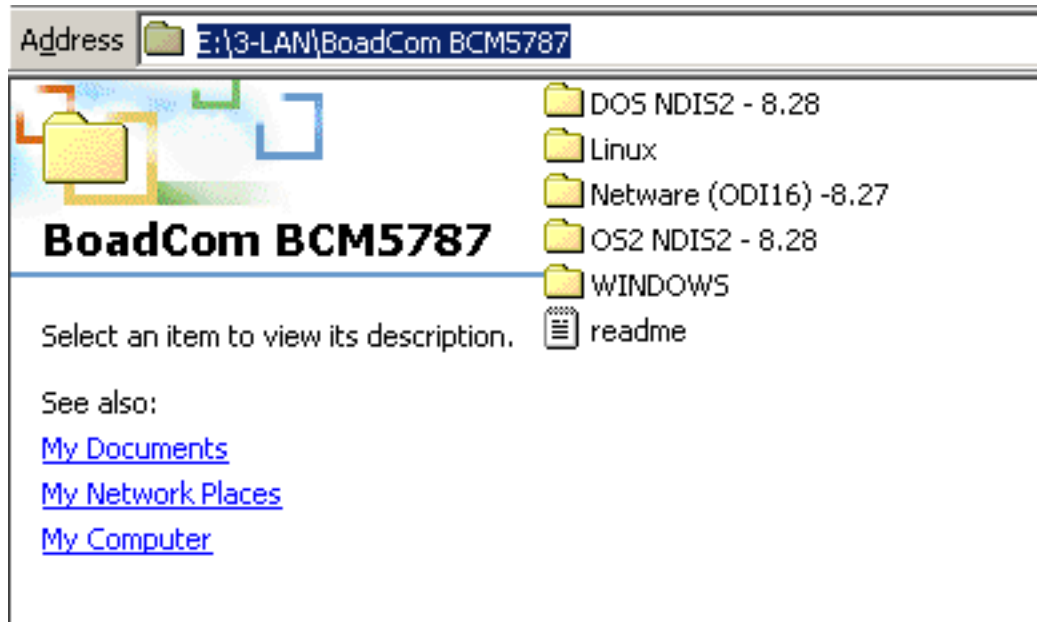

Figure 7-18: Location Browsing Window

Step 9: Click **OK** to continue. A driver files location menu window appears. Click **NEXT** to continue. The driver is installed.

7.5 Realtek HD Audio Driver (ALC883) Installation

To install the Realtek High Definition (HD) Audio driver, please follow the steps below.

7.5.1 BIOS Setup

- Step 1:** Enter the BIOS setup. To do this, reboot the system and press **DEL** during POST.
- Step 2:** Go to the Southbridge Configuration menu. Set the **Audio Controller** option to [Azalia]. See **Section 6.7.2** for details.
- Step 3:** Press **F10** to save the changes and exit the BIOS setup. The system reboots.

7.5.2 Driver Installation

- Step 1:** Insert the SIS Solution CD that came with the package.
- Step 2:** From the main driver menu, navigate to **X:\4-AUDIO\AC-KIT883HD\Windows** (or other appropriate OS). **X:** represents the system CD drive. A new window appears showing the folder contents (**Figure 6-26**).

WSB-9452 PICMG 1.0 CPU Card

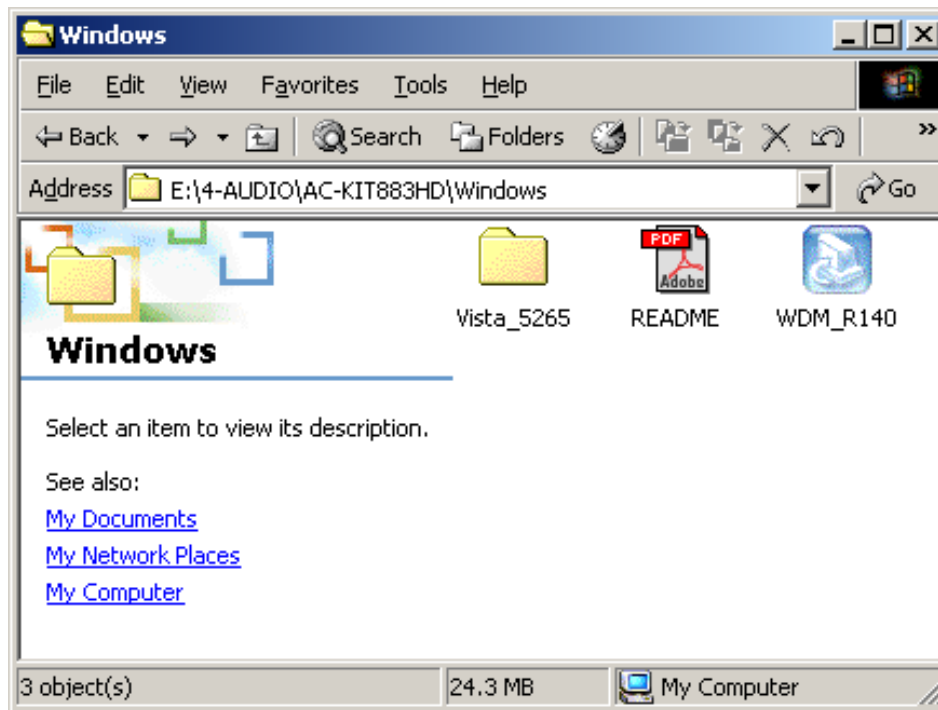

Figure 7-19: 4-AUDIOAC-KIT883HDWindows Folder

Step 3: Double-click the **WDM_R140** icon to begin the driver installation process.

Step 4: Once the **WDM_R140** icon is double clicked, the contents of the installation package are extracted. See **Figure 7-20**.



Figure 7-20: HD Audio Driver Setup Extracting Files

Step 5: The **Welcome** screen appears. Click **NEXT**. See **Figure 7-21**.

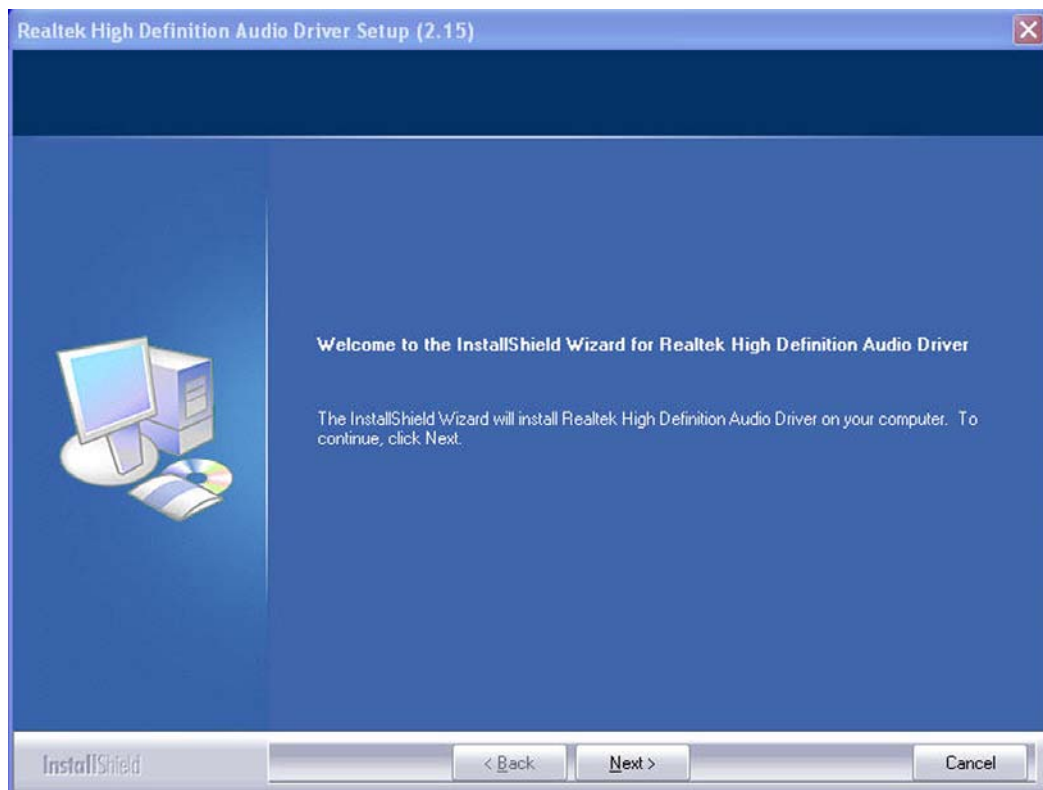

Figure 7-21: HD Audio Driver Setup Welcome Screen

Step 6: The driver is automatically installed.

Step 7: After the driver installation process is complete, a confirmation screen shown in **Figure 7-22** appears.

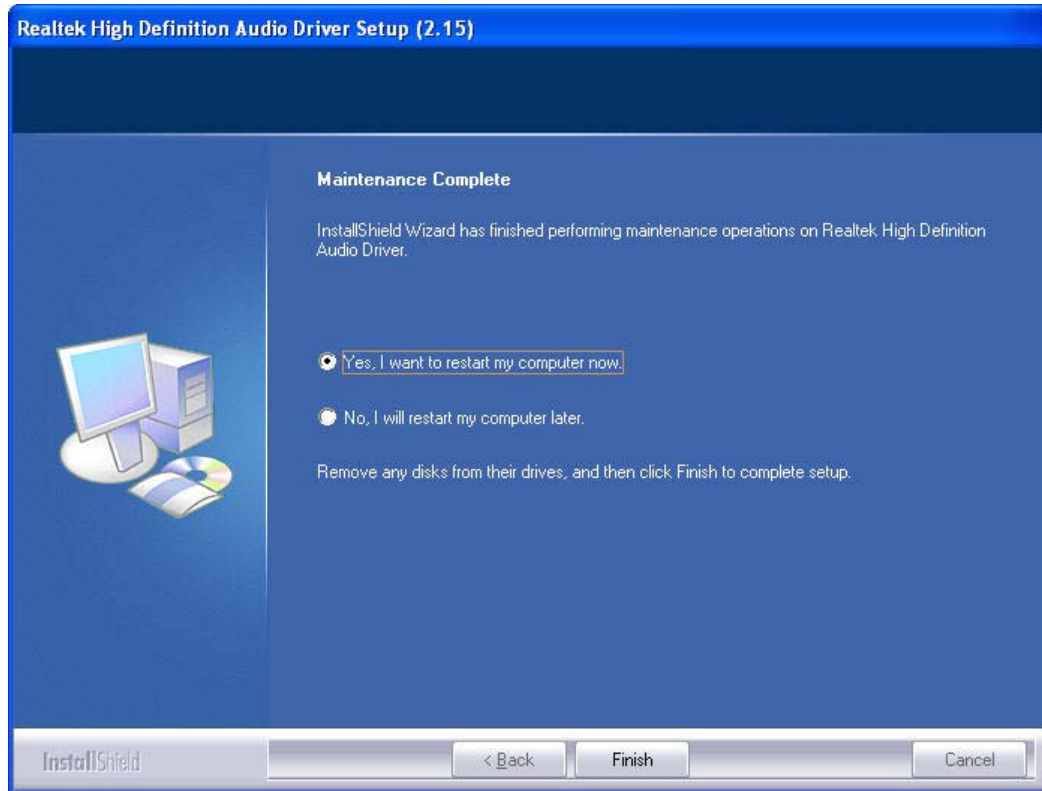

Figure 7-22: HD Audio Driver Installation Complete

Step 8: The confirmation screen shown in **Figure 7-22** allows you to restart the computer immediately after the installation is complete or to restart the computer later. For the settings to take effect the computer must be restarted. Once you have decided when to restart the computer, click the **“FINISH”** button.

7.6 Realtek AC`97 Audio Driver (ALC665) Installation

To install the Realtek AC`97 audio driver, please follow the steps below.

7.6.1 BIOS Setup

- Step 1:** Enter the BIOS setup. To do this, reboot the system and press **DEL** during POST.
- Step 2:** Go to the Southbridge Configuration menu. Set the **Audio Controller** option to [AC`97]. See **Section 6.7.2** for details.
- Step 3:** Press **F10** to save the changes and exit the BIOS setup. The system reboots.

7.6.2 Driver Installation

- Step 1:** Insert the SIS Solution CD that came with the package.
- Step 2:** From the main driver menu, navigate to **X:\4-AUDIO\AC-KIT08R\Windows** (or other appropriate OS). **X:** represents the system CD drive. A new window appears showing the folder contents (**Figure 7-23**).

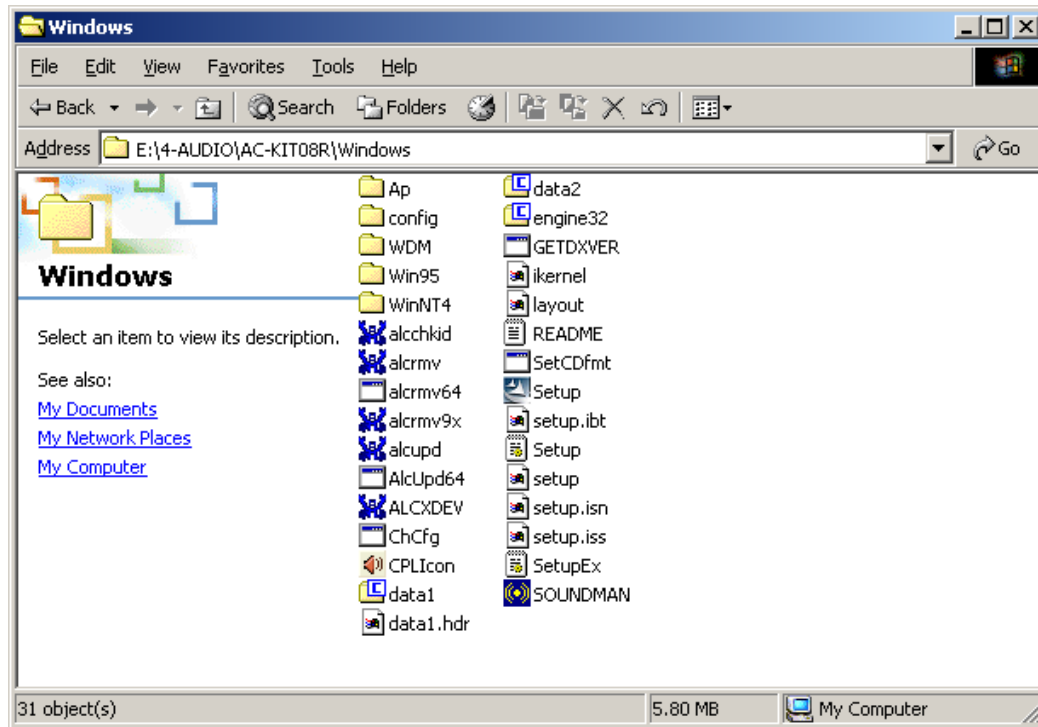

Figure 7-23: CD 4-AUDIO\AC-KIT08R\Windows Folder

Step 3: Double-click the **Setup.exe** file to begin the driver installation process.

Step 4: Once you double click the **Setup** icon, the install shield wizard for the audio driver starts. See **Figure 7-24**.

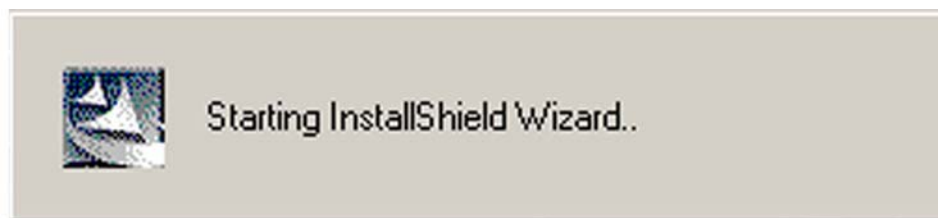

Figure 7-24: AC`97 Audio Driver Install Shield Wizard Starting

Step 5: The Realtek Audio Setup prepares the install shield to guide you through the rest of the setup process. See **Figure 7-21**.

WSB-9452 PICMG 1.0 CPU Card

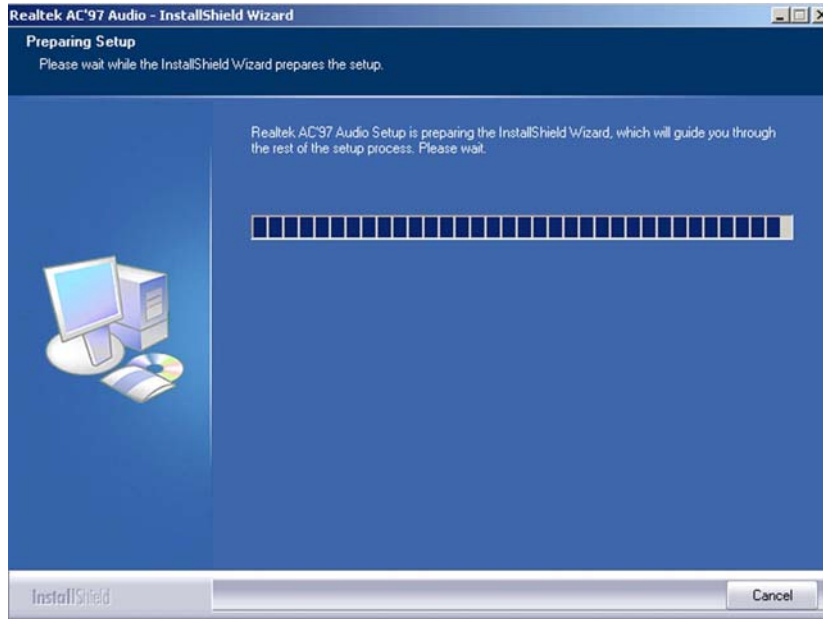

Figure 7-25: AC`97 Audio Driver Setup Preparation

Step 6: After the install shield is prepared, the welcome screen shown in **Figure 7-26** appears. To continue the installation process, click the “**NEXT**” button. The install shield starts to configure the new software as shown in **Figure 7-27**.

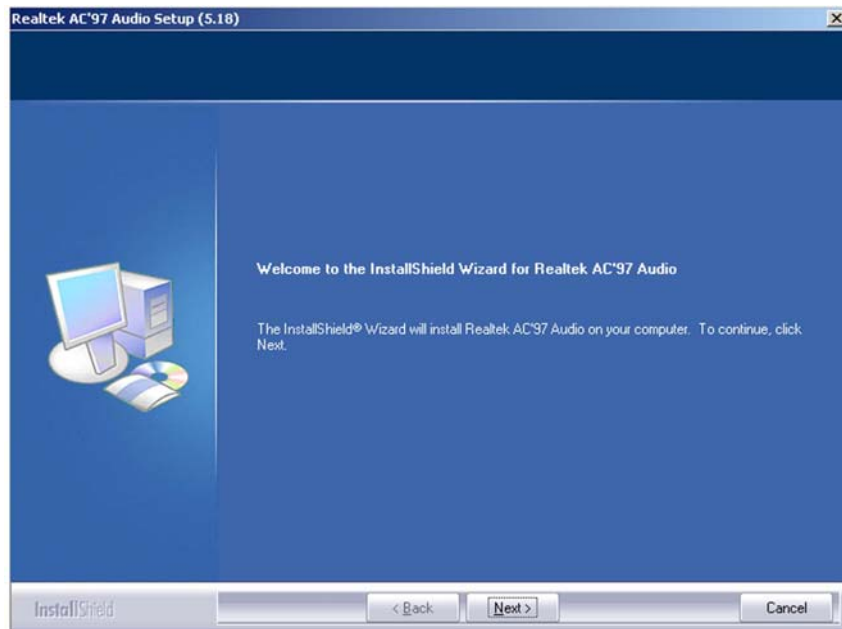

Figure 7-26: AC`97 Audio Driver Welcome Screen

WSB-9452 PICMG 1.0 CPU Card

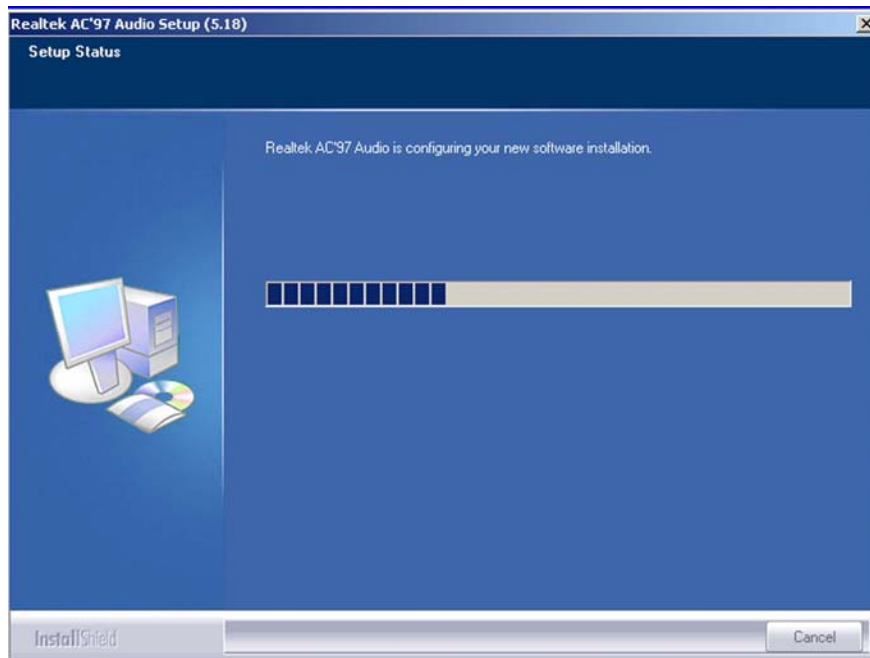

Figure 7-27: AC'97 Audio Driver Software Configuration

Step 7: At this stage the “Digital Signal Not Found” screen appears (Figure 7-28). To continue the installation process, click the “YES” button.



Figure 7-28: AC'97 Audio Driver Digital Signal

WSB-9452 PICMG 1.0 CPU Card

Step 8: After clicking the “YES” button in **Figure 7-28**, the installation of the driver begins (**Figure 7-29**).

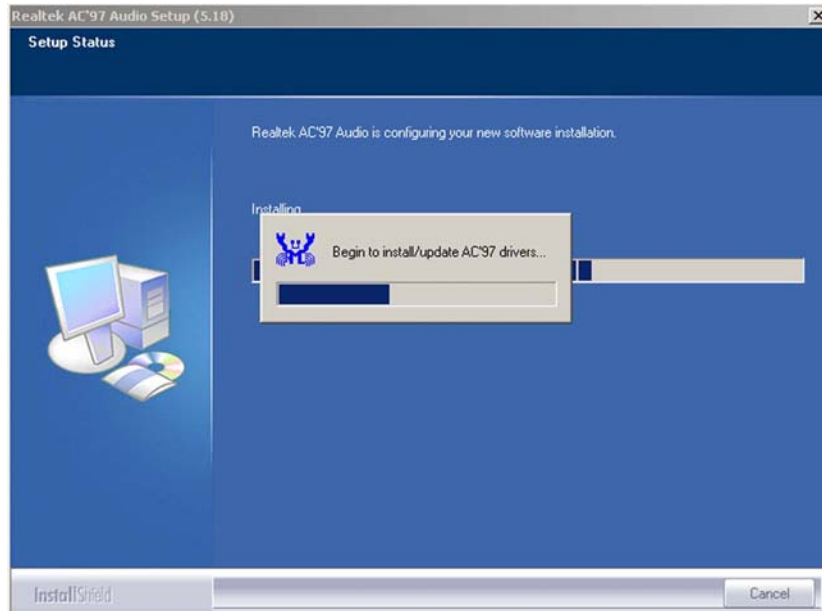

Figure 7-29: AC`97 Audio Driver Installation Begins

Step 9: After the driver installation process is complete, a confirmation screen shown in **Figure 7-30** appears.

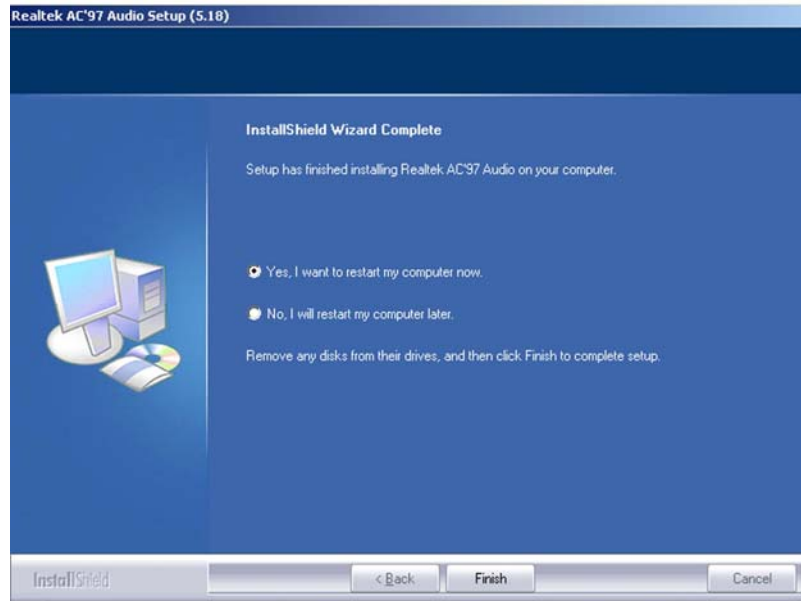

Figure 7-30: AC`97 Audio Driver Installation Complete

Step 10: The confirmation screen shown in **Figure 7-30** allows you to restart the computer immediately after the installation is complete or to restart the computer later. For the settings to take effect the computer must be restarted. Once you have decided when to restart the computer, click the “**FINISH**” button.

Appendix

A

BIOS Configuration Options

A.1 BIOS Configuration Options

Below is a list of BIOS configuration options described in **Chapter 0**.

System Overview	108
Intel(R) SpeedStep(tm) tech. [Automatic]	112
ATA/IDE Configuration [Compatible].....	113
Legacy IDE Channels [SATA Pri, PATA Sec].....	114
IDE Master and IDE Slave	114
Type [Auto].....	115
ZIP	116
LS-120	116
LBA/Large Mode [Auto].....	116
Block (Multi Sector Transfer) [Auto].....	117
PIO Mode [Auto].....	117
DMA Mode [Auto].....	118
S.M.A.R.T [Auto].....	118
32Bit Data Transfer [Enabled]	118
Floppy A/B [1.44 MB 3½”].....	119
On-board Floppy Controller [Enabled]	121
Floppy Drive Swap [Disabled]	121
Serial Port1 Address [3F8/IRQ4]	121
Serial Port1 Mode [Normal].....	122
Serial Port2 Address [2F8/IRQ3]	122
Serial Port2 Mode [Normal].....	122
Parallel Port Address [Disabled].....	123
Parallel Port Mode [Normal].....	123
Parallel Port IRQ [IRQ7].....	124
CPU FAN Mode Setting: [Full On mode]	125
CPU Temp. Limit of OFF	125
CPU Temp. Limit of Start	125
CPU Temp. Limit of Full	125

WSB-9452 PICMG 1.0 CPU Card

CPU Fan Start PWM	125
Slope PWM 1: 0 PWM, 1 PWM (Default), 2 PWM, 4 PWM, 8 PWM, 16 PWM, 32 PWM or 64 PWM	125
CPU Fan PWM Control	125
ACPI Aware O/S [Yes]	127
Suspend mode [Auto]	129
Repost Video on S3 Resume [Yes]	129
Power Management/APM [Enabled].....	130
Restore on AC Power Loss by IO [Last State].....	131
Power Button Mode [On/Off]	131
Resume on Ring [Disabled]	131
Resume on PME# [Disabled]	132
Resume On RTC Alarm [Disabled].....	132
RTC Alarm Date (Days)	132
RTC Alarm Time.....	132
MPS Revision [1.4].....	133
Remote Access [Disabled].....	134
Serial Port Number	135
Serial Port Mode.....	135
Flow Control.....	135
Redirection after BIOS POST.....	135
Terminal Type.....	135
VT-UTF8 Combo Key Support	135
Sredir Memory Display Delay	135
Serial Port Number [COM1]	135
Base Address, IRQ [2F8h,3].....	136
Serial Port Mode [115200 8,n,1].....	136
Flow Control [None].....	136
Redirection After BIOS POST [Always]	137
Terminal Type [ANSI]	137
VT-UTF8 Combo Key Support [Disabled].....	137

Sredir Memory Display Delay [Disabled].....	138
TCG/TPM Support [No].....	139
USB Configuration.....	140
USB Devices Enabled.....	140
USB Function [8 USB Ports].....	141
USB 2.0 Controller [Enabled].....	141
Legacy USB Support [Enabled].....	141
USB2.0 Controller Mode [HiSpeed].....	142
BIOS EHCI Handoff [Enabled]	142
Clear NVRAM [No].....	145
Plug & Play O/S [No].....	146
PCI Latency Timer [64]	146
Allocate IRQ to PCI VGA [Yes]	147
Palette Snooping [Disabled]	147
PCI IDE BusMaster [Enabled]	148
OffBoard PCI/ISA IDE Card [Auto]	148
IRQ# [Available].....	149
DMA Channel# [Available]	150
Reserved Memory Size [Disabled]	150
Quick Boot [Enabled]	152
Quiet Boot [Disabled]	153
AddOn ROM Display Mode [Force BIOS]	153
Bootup Num-Lock [On]	153
PS/2 Mouse Support [Auto]	154
Giga LAN Boot ROM Support [Disabled].....	154
Change Supervisor Password.....	159
Change User Password.....	160
DRAM Frequency [Auto]	162
Configure DRAM Timing by SPD [Enabled]	163
Memory Hole [Disabled].....	163
Boots Graphics Adapter Priority [IGD].....	164

Internal Graphics Mode Select [Enabled, 8MB]	164
DVMT Mode Select [DVMT Mode].....	165
DVMT/FIXED Memory [128MB]	166
Boot Display Device [CRT on Port 0].....	166
Flat Panel Type [640*480].....	167
Local Flat Panel Scaling [Auto].....	167
TV Connector [Auto].....	167
HDTV Output [Auto].....	168
TV Standard [VBIOS-Default].....	169
Audio Controller [AC`97 Audio]	171
OnBoard LAN1 [Auto]	171
On-board LAN2 [Auto].....	171
Mini Card [Auto].....	171
SATA Controller	172
SATA Controller Mode Select.....	172
Save Changes and Exit	173
Discard Changes and Exit	173
Discard Changes.....	174
Load Optimal Defaults.....	174
Load Failsafe Defaults.....	174



Appendix

B

Watchdog Timer



NOTE:

The following discussion applies to DOS environment. It is recommended you contact IEI support or visit our website for specific drivers for more sophisticated operating systems, e.g., Windows and Linux.

The Watchdog Timer is provided to ensure that standalone systems can always recover from catastrophic conditions that cause the CPU to crash. This condition may have occurred by external EMI or a software bug. When the CPU stops working correctly, Watchdog Timer will either perform a hardware reset (cold boot) or a Non-Maskable Interrupt (NMI) to bring the system back to a known state.

A BIOS function call (INT 15H) is used to control the Watchdog Timer:

INT 15H:

AH – 6FH Sub-function:	
AL – 2:	Sets the Watchdog Timer's period.
BL:	Time-out value (Its unit-second is dependent on the item "Watchdog Timer unit select" in CMOS setup).

Table B-1: AH-6FH Sub-function

You have to call sub-function 2 to set the time-out period of Watchdog Timer first. If the time-out value is not zero, the Watchdog Timer will start counting down. While the timer value reaches zero, the system will reset. To ensure that this reset condition does not occur, calling sub-function 2 must periodically refresh the Watchdog Timer. However, the Watchdog timer will be disabled if you set the time-out value to be zero.

A tolerance of at least 10% must be maintained to avoid unknown routines within the operating system (DOS), such as disk I/O that can be very time-consuming.



NOTE:

When exiting a program it is necessary to disable the Watchdog Timer, otherwise the system will reset.

Example program:

; INITIAL TIMER PERIOD COUNTER

;

W_LOOP:

```

MOV    AX, 6F02H    ;setting the time-out value
MOV    BL, 30      ;time-out value is 48 seconds
INT    15H

```

;

; ADD YOUR APPLICATION PROGRAM HERE

;

```

CMP    EXIT_AP, 1    ;is your application over?
JNE    W_LOOP      ;No, restart your application

```

```

MOV    AX, 6F02H    ;disable Watchdog Timer
MOV    BL, 0        ;
INT    15H

```

;

; EXIT ;

Appendix

C

External AC'97 Audio CODEC

C.1 Introduction

The audio functionalities of the WSB-9452 CPU card can be implemented using a separately purchased audio module, the AC-KIT08R-R10. The audio kit is powered by Realtek ALC655/883, a 16-bit, full duplex AC'97 2.3 compatible audio CODEC with 48KHz sampling rate. The audio kit functionalities are interfaced through three (3) phone jack connectors and two (2) pin headers including:

1. A LINE input shared with surround output
2. A MIC input shared with Center and LFE output
3. A LINE output
4. Analog line-level stereo inputs with 5-bit volume control: CDIN1 and AUXIN1.

Both Front_out and Surround_out are equipped with a built-in 50mW/20ohm amplifier. The ALC655 supports host/soft audio from Intel ICHx chipsets as well as audio controller based VIA/SIS/Ali/ATI chipset with bundled Windows series drivers (XP/ME/2000/98/NT), EAX/Direct Sound 3D/I3DL2/A3D compatible sound effect utilities supporting Karaoke, 26 kinds of environment sound emulations with 10-band equalizer, and HRTF 3D positional audio. The audio kit provides an excellent entertainment package sufficient for today's multimedia systems.

WSB-9452 PICMG 1.0 CPU Card

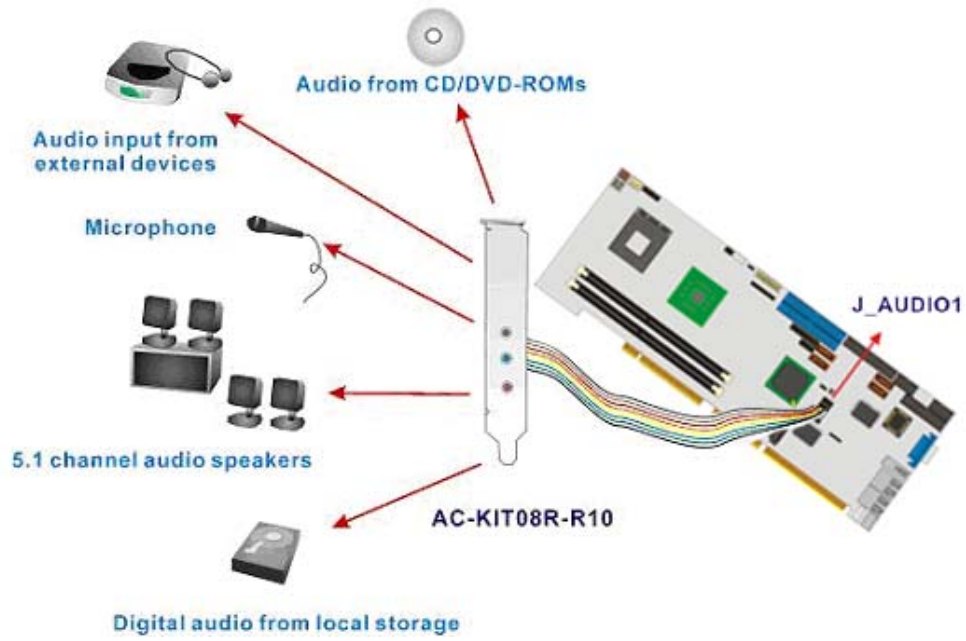

Figure C-1: Audio Functionalities via the Audio Kit

C.2 Physical Connection

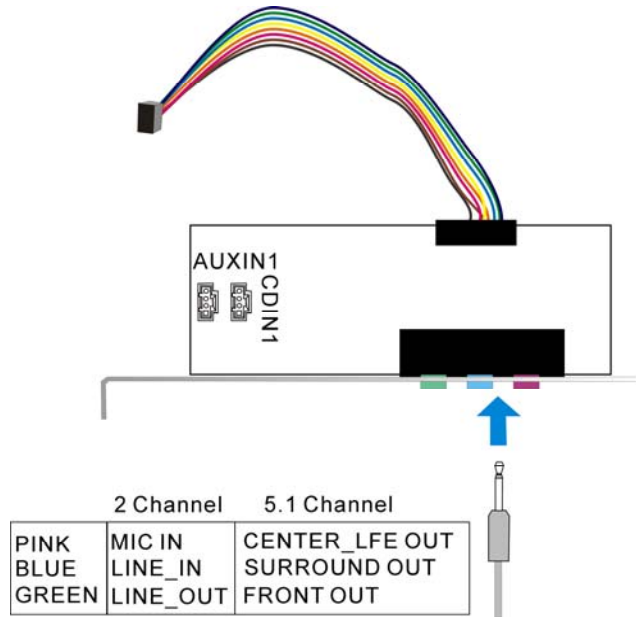

Figure C-2: Audio Kit Connectors

The audio kit comes with a PCI slot bracket for the installation into a PC case or rackmount chassis. Connect the 10-pin header to the J_AUDIO1 header as shown above, and if necessary, connect the CDIN1 and AUXIN1 to optical drives or other audio sources, e.g., an MPEG card, using a 4-pin cable. Note that depending on the devices you connect to, the phone jacks have different functions with different audio installation modes (2 channel or 5.1 channel modes).

C.3 Driver Installation

The driver installation has been described in **Chapter 7**.

After reboot, you should be able to find the sound effect configuration utility in Windows Control Panel (see **Figure C-3**); and if peripheral speakers have been properly connected, hear the sound effects.

WSB-9452 PICMG 1.0 CPU Card

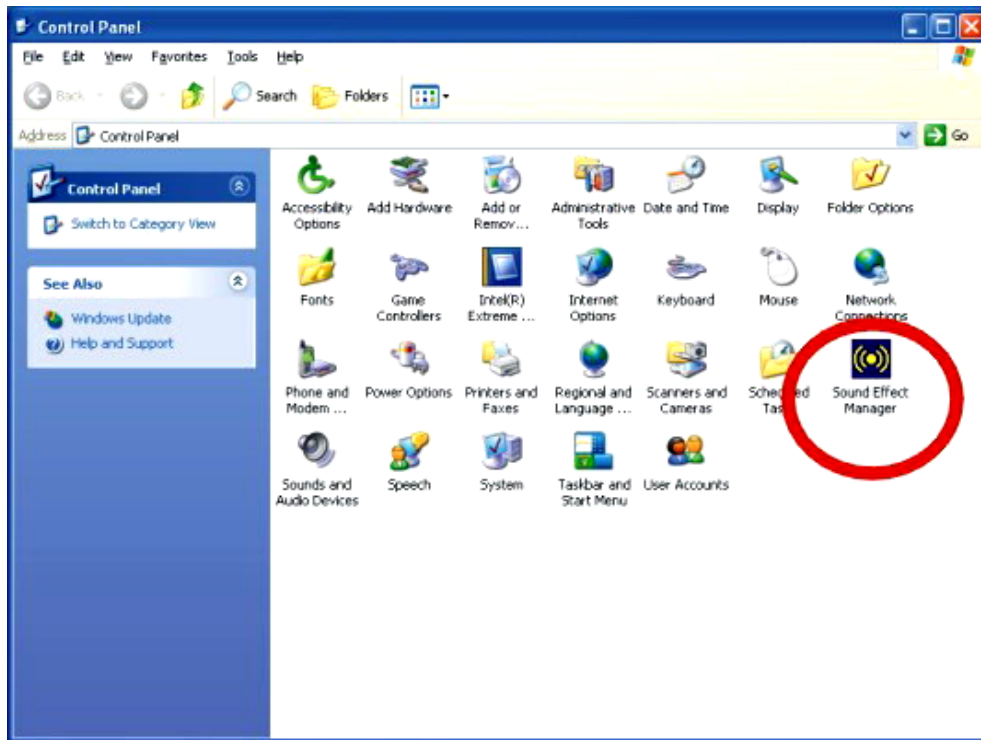

Figure C-3: Sound Effect Manager Icon

C.4 Sound Effect Configuration

After installing the audio CODEC driver, you should be able to use the multi-channel audio features now. Click the audio icon from the Notification Area from system task bar (see **Figure C-5**). The shortcut to the configuration utility is also available through the **Sound Effect Manager** icon in the **Control Panel** (**Figure C-4**).

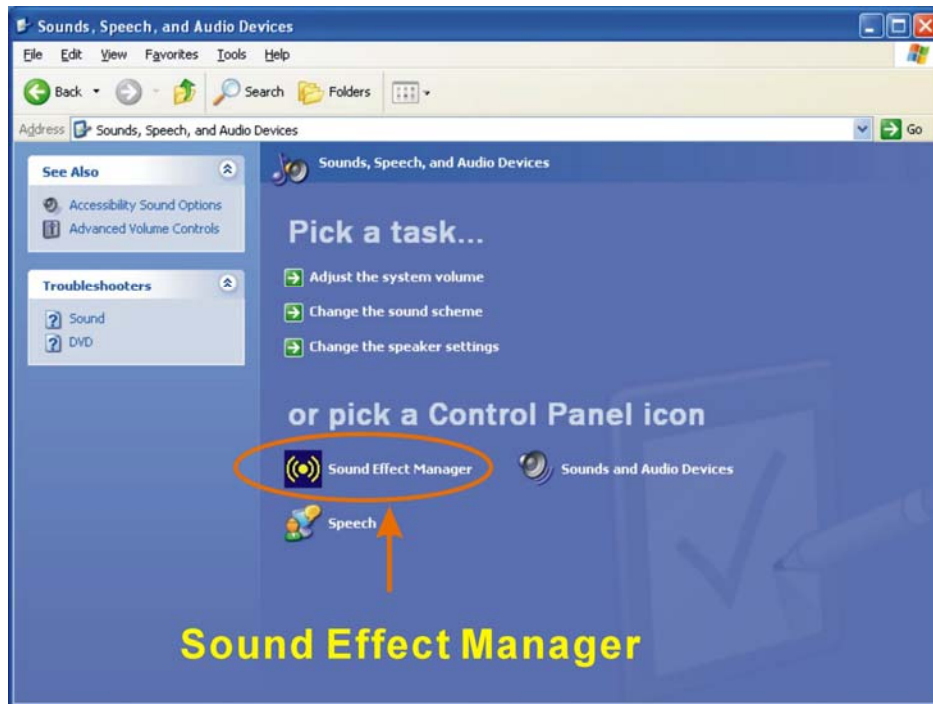

Figure C-4: Sound Effect Manager Icon [Control Panel]

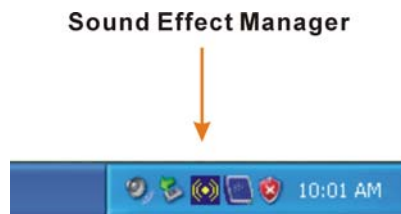

Figure C-5: Sound Effect Manager Icon [Task Bar]

C.5 Sound Effect

You may select a pre-configured sound environment setting with the preset equalizer settings. You may also load an equalizer setting or make a new equalizer setting using the “Load EQ Setting” and “Save Preset” button. (See **Figure C-7**)

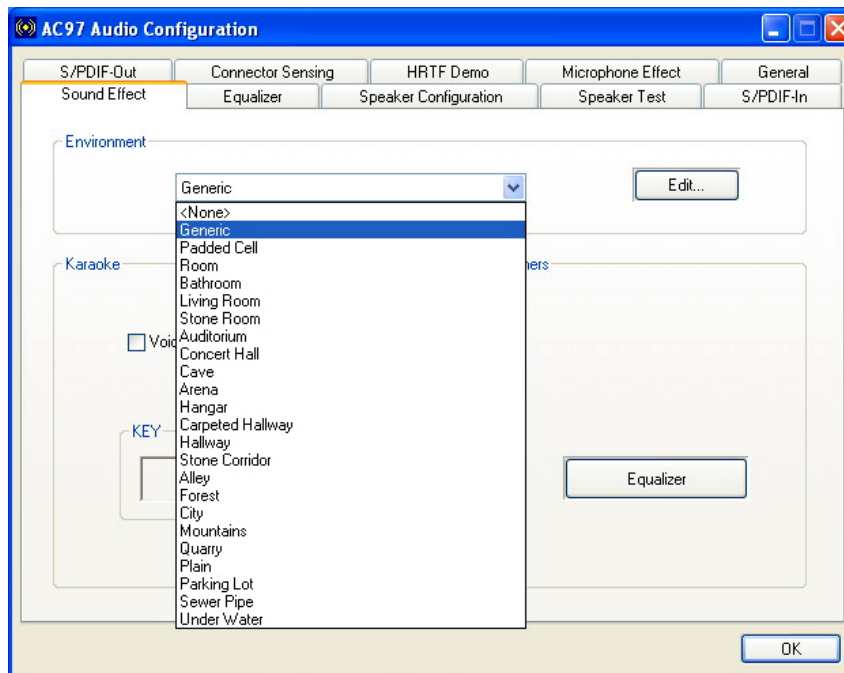

Figure C-6: Setting Sound Effects

C.6 Environment Simulation

This is the default screen whenever the configuration utility is opened.

You may select different sound environment modes by a single click on the Environment pull-down list. There are a total of 23 preset environment modes (see **Figure C-7**). You may also fine-tune the environment setting by clicking the **Edit** button on the right, which displays an editor window. Select a preset mode you want to edit. Select a preset mode, and then select one of the property values from the list below by a single click. Use the scroll bar below to adjust the properties setting. When the adjustment is done, click the Save button to proceed.

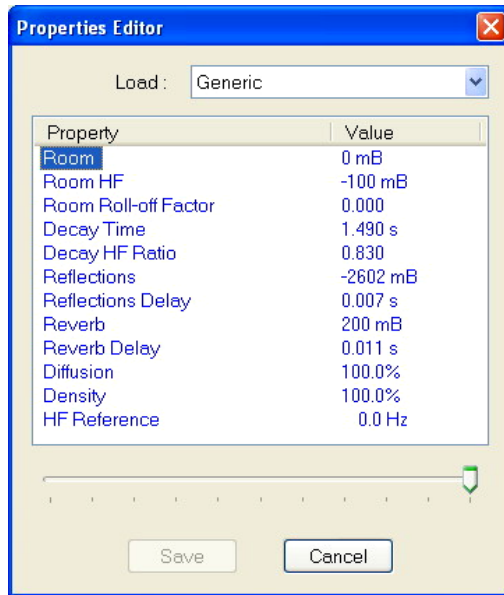

Figure C-7: Sound Effects Properties Editor

C.7 Karaoke Mode

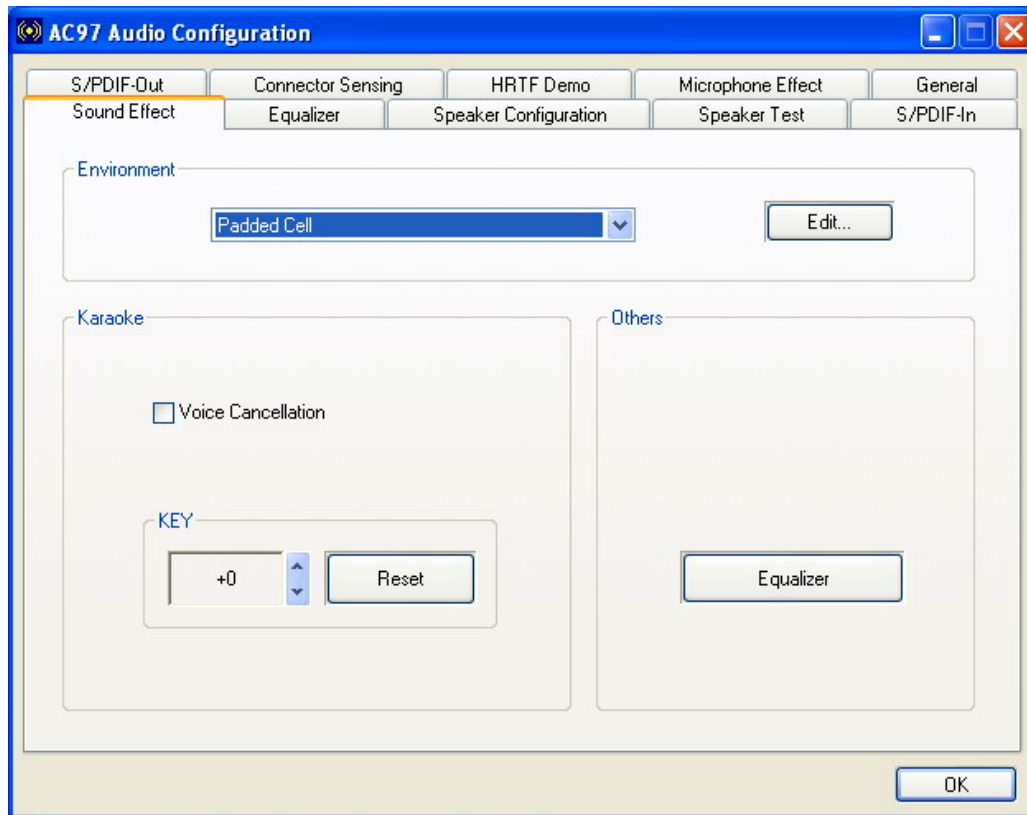

Figure C-8: Karaoke Mode

The Karaoke mode shown in **Figure C-8** allows you to eliminate the vocal of the music you play or adjust the key to accommodate your range.

The configuration options that come with the Karaoke function include:

1. **Voice Cancellation:** This checkbox, when selected, disables the vocal part of the music you play in your computer while the background music remains.
2. **Key adjustment:** Use the Up or Down arrow icons to find a key that fits your vocal range.



NOTE:

The Equalizer button on the default display brings you to the same configuration window as the Equalizer function tab on top of the window.

C.8 Equalizer Selection

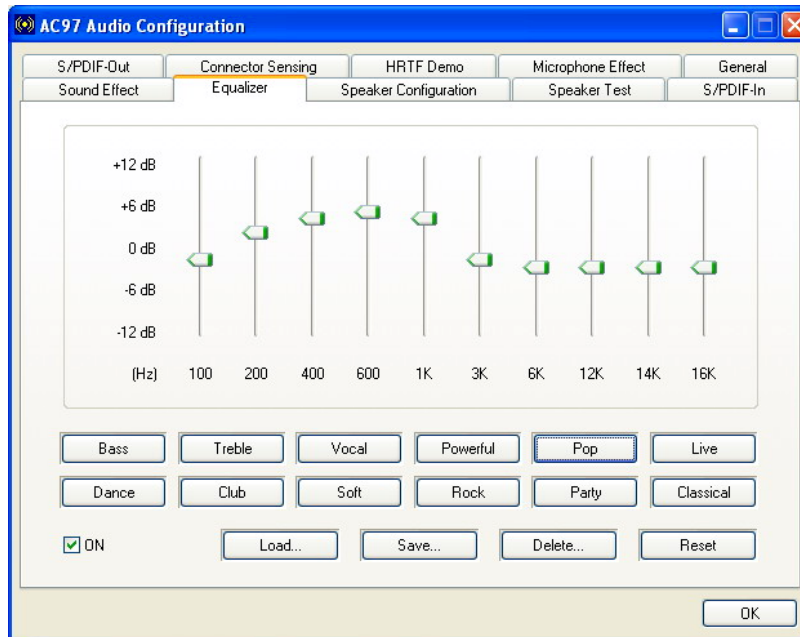

Figure C-9: Equalizer Settings

The equalizer in **Figure C-9** allows users to change sound effect parameters. The default screen shows equalized values. You may also select preset modes from the buttons below. The configurable values include 10 bands of equalizer ranging from 100Hz to 16KHz. Use the scroll bar to fine-tune, and use the **Load**, **Save**, **Delete**, and **Reset** buttons to edit your settings.

C.9 Speaker Configuration

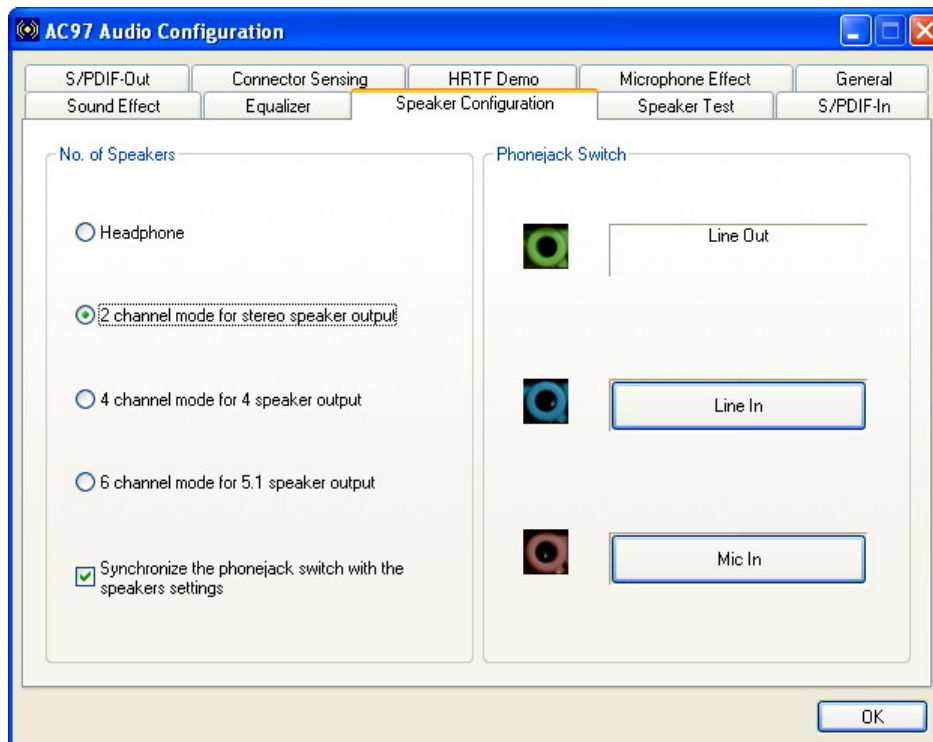

Figure C-10: Speaker Configuration

In this functional window, you can configure your multi-channel speaker settings.

Select the audio configuration from the **No. of Speakers** section on the left by clicking on one of the check circles.

The configurable options are:

1. Headphone
2. Channel mode for stereo speaker output
3. Channel mode for 4 speaker output
4. Channel mode for 5.1 speaker output
5. Synchronize the phonejack switch with speakers settings

Select a speaker configuration by selecting its check circle, and then click **OK** to apply the configuration change.

Connect your speakers to the corresponding phonejacks. It is recommended you write down your configuration, power off the system, and then complete the physical connections.

Select from the **Phonejack Switch** section if you want to re-define the phonejacks. Click the specific phonejack button for several times to change its input/output functionality.

C.10 Speaker Test

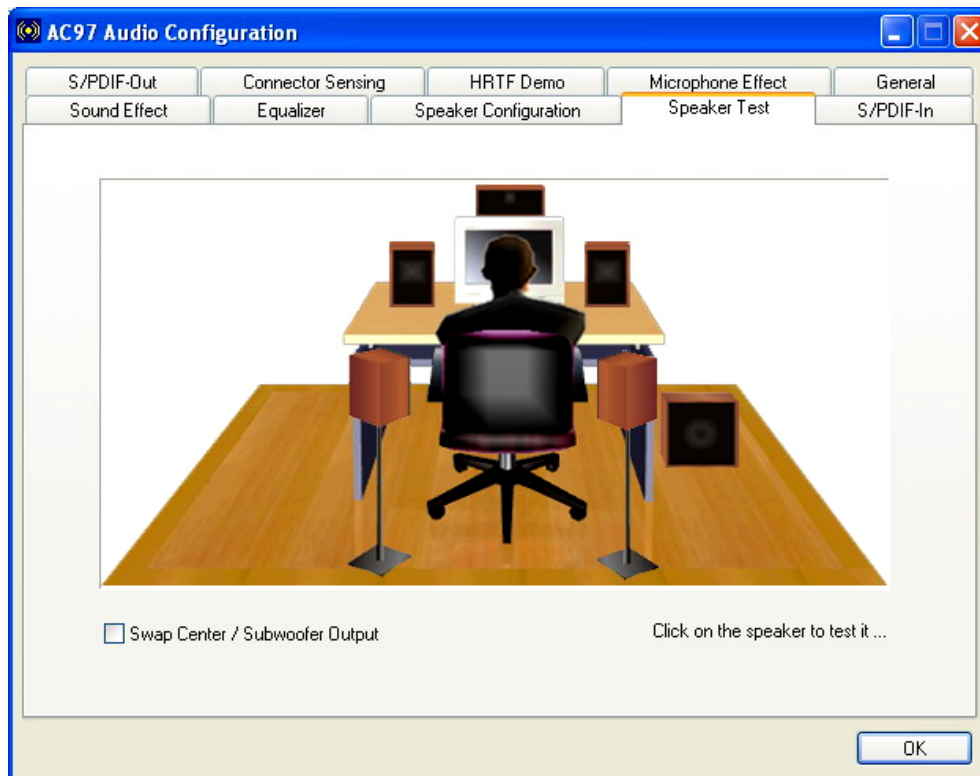

Figure C-11: Audio Configuration

The audio configuration window in **Figure C-11** allows you to test each connected speaker to see if your 4-channel or 6-channel audio operates properly. If any speaker malfunctions, you should then check the cabling or replace the malfunctioning parts.

WSB-9452 PICMG 1.0 CPU Card

Select each specific speaker to test its functionality. The speaker you select will be highlighted and sound should be generated.



NOTE:

1. The test scenario that appears in the **Speaker Test** window corresponds to the number of speakers you selected in the **Sound Effect** window.
 2. You should select and deselect the **Swap Center/Subwoofer Output** check box to see if these two devices properly work.
-

C.11 S/PDIF-In & S/PDIF-Out

These functions are currently not supported.

C.12 Connector Sensing



Figure C-12: Connector Sensing

Realtek ALC655/883 supports Jack Sensing functionality. If an audio device is plugged into the wrong connector, a warning message will display informing users to correct the physical connections.

Click the Start button in **Figure C-12** to start the sensing. Please remember to close all running audio-related programs before executing the sensing operation.

The EZ-Connection screen in **Figure C-13** shows the result of sensing test.

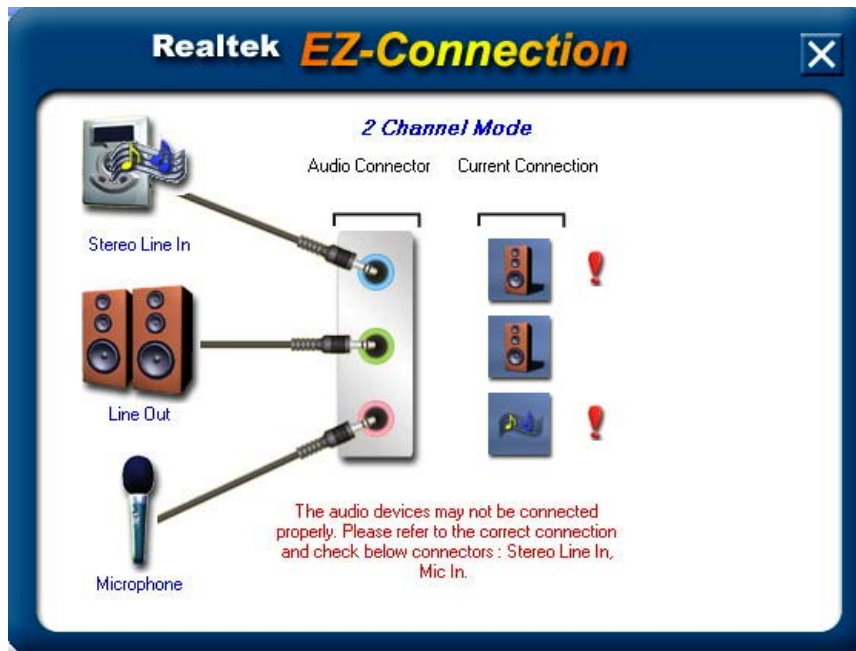

Figure C-13: EX Connection

The “Audio Connector” column shows the settings used in the “Speaker Configuration” window.

The “Current Connection” column shows the types of devices detected during test. If the result does not match the physical connection, an exclamation mark will appear. (See **Figure C-14**)

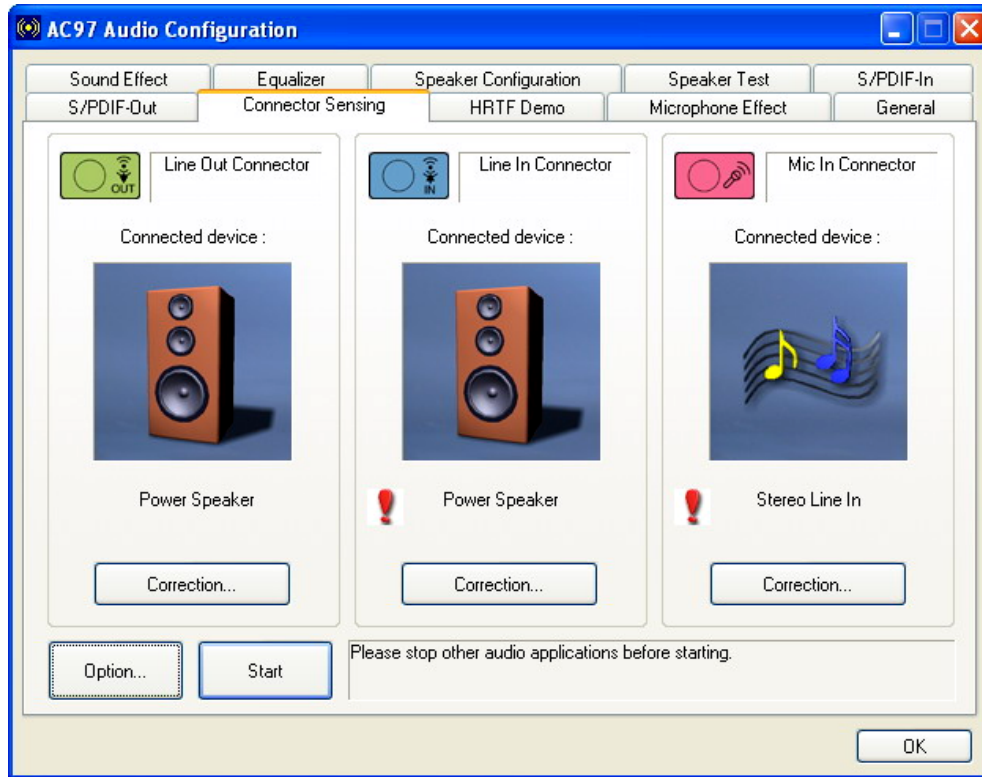

Figure C-14: Connector Sensing Test Result

After closing the EZ-Connector screen, the following window should appear showing the latest connection status.

C.13 HRTF Demo

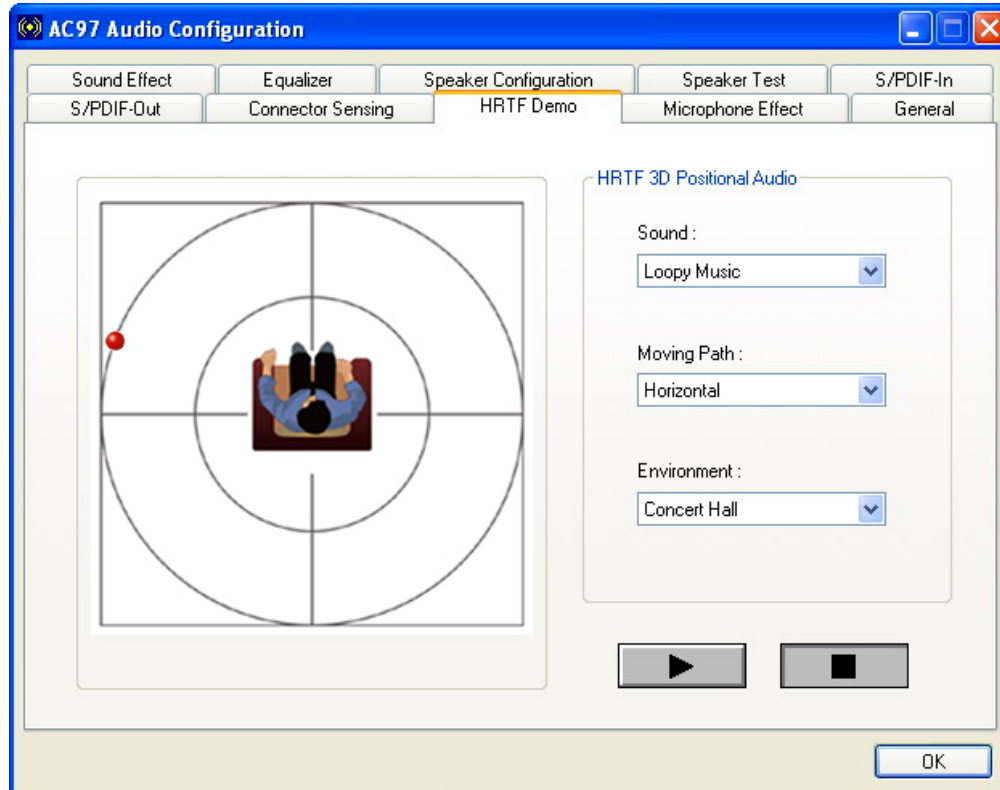

Figure C-15: HRTF Demo

The HRTF window in **Figure C-15** allows you to adjust your HRTF (Head Related Transfer Functions) 3D positional audio before playing 3D applications. Select a preferred **Environment** mode and/or different **Sound** and **Moving Path** settings.

C.14 Microphone Effect

This window provides an option, Noise Suppression. Select its check box to enable this functionality.

C.15 General

The general window in **Figure C-16** provides information about this AC'97 audio configuration utility including **Audio Driver** version, **DirectX** version, **Audio Controller**, and **AC'97 Codec**. You may also change the language of this utility through the **Language** pull-down menu.

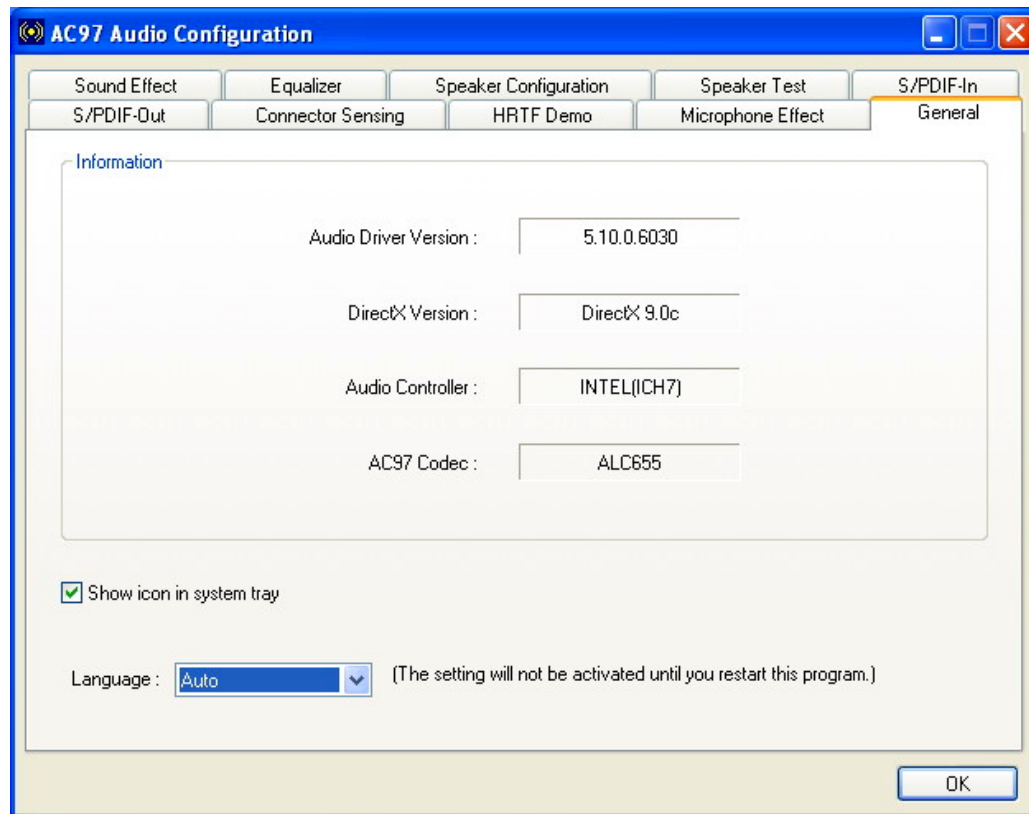

Figure C-16: General

Appendix

D

Jmicron RAID Setup

D.1 Introduction

D.1.1 RAID Support

The Jmicron JMB363 chipset integrated controller in WSB-9452S and WSB-9452SDVI models supports the following RAID configurations on the SATA3 and SATA4 connectors.

- JBOD
- RAID0
- RAID1

D.1.2 What is RAID

RAID, or redundant array of inexpensive disks, is a method of saving data on multiple disks so that if one of the disks is damaged or destroyed, the data on the disks is not lost.

Only the three RAID levels listed above can be implemented on your system

- **JBOD** stands for Just a Bunch Of Disks. This is not a RAID level. If any thing happens to one hard drive, all the information on that drive is lost.
- **RAID0** refers to disk striping. Data is distributed (striped) over multiple disks. This increases the overall disk performance but the data is not redundantly stored and therefore any damage to the system disks will result in a loss of information.
- **RAID1** refers to disk mirroring. The information on one disk is completely mirrored onto a second disk. The effective storage capacity of the hard disks is halved but the data on the disks is safe. If one of the disks is destroyed or damaged in any way the information on that disk is retrievable from the second disk.

D.2 RAID Setup

D.2.1 Introduction

To setup the RAID, the following procedures must be completed.

Step 1: Two SATA drives, preferably with the same model and capacity, must be installed onto the system. Refer to **Section 5.4.5**.

Step 2: The RAID BIOS must be configured.

D.2.2 Install SATA Drives

To implement the on-chip RAID function, two SATA drives must be connected to the system. Use the SATA drive cables that came with the system to connect the SATA drives. Refer to **Section 5.4.5**.

D.2.3 Configure the SATA Controller in BIOS

To configure the RAID BIOS, follow the steps below:

Step 1: Turn on the motherboard and enter the BIOS setup utility. Do this by pressing **DELETE** when the system boots up.

Step 2: Select the **Advanced Settings** menus.

Step 3: Select the **IDE Configuration** sub-menu.

Step 4: In the **IDE Configuration** sub-menu, select the **ATA/IDE Configuration** option. Make sure it is set to the default setting [Compatible]. Keep the default setting of the **Legacy IDE Channels** option [SATA Pri, PATA Sec].

Step 5: Select the **Chipset** menu.

Step 6: Select the **Southbridge** sub-menu.

Step 7: Set the **SATA Controller Mode Select** option to [RAID].

Step 8: Press **F10** to save the changes and exit the BIOS setup utility.

D.2.4 Configure the RAID BIOS

The next step is to configure the RAID BIOS. To do this, follow the steps below.

Step 1: Restart the system.

Step 2: During POST, the system prompts the user to press <CTRL> and <J> to enter the RAID Setup Utility (**Figure D-1**).

```

JMicron Technology Corp.      PCI-to-SATA II / IDE RAID Controller  BIOSv1.06.60
Copyright © 2005 JMicron Technology      http://www.jmicron.com

HDD0:  ST3300622AS                XXXGB  Non-RAID
HDD1:  ST3120813AS                XXXGB  Non-RAID

Press <Ctrl-J> to enter RAID Setup Utility...
```

Figure D-1: Enter the RAID Setup Utility

Step 3: The main RAID Setup Utility menu opens (**Figure D-2**). To move from one window to another, press the **Tab** key. Below is a brief description of each window.

- **Main Menu** – This window lists the different actions you can perform in the RAID Setup Utility.
- **Hard Disk Drive List** – This window lists the SATA disk drives installed and the following information about the disks:
 - Model name
 - Capacity
 - Type/Status (RAID or non-RAID)
- **RAID Disk Drive List** – This window is empty if no RAID volume is configured. If a RAID volume is configured, the following information is displayed:
 - Model name (user-defined RAID volume name)
 - RAID level
 - Capacity
 - Status
 - Member disks' corresponding numbers

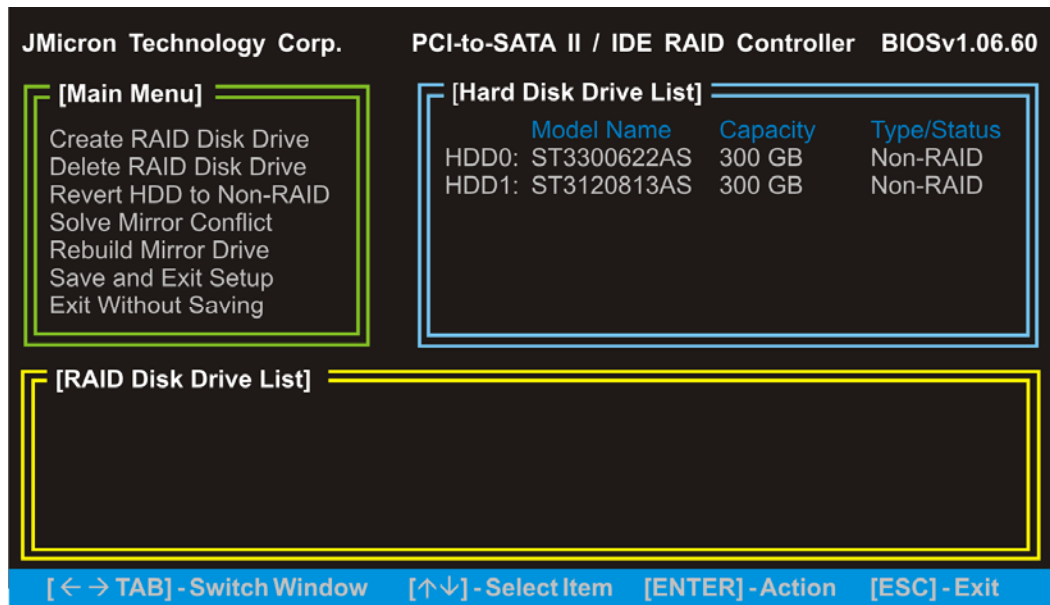

Figure D-2: Enter the RAID Setup Utility

D.2.4.1 Create a RAID volume

Step 1: In the RAID Setup Utility main menu, highlight **Create RAID Disk Drive** (Figure D-3). Press **ENTER**.



Figure D-3: Create RAID Disk Drive

Step 2: The **Create New RAID** window opens. The **Name** item is highlighted (**Figure D-4**). Enter a name made up of one to 16 characters for the RAID volume to be created, then press **ENTER**.

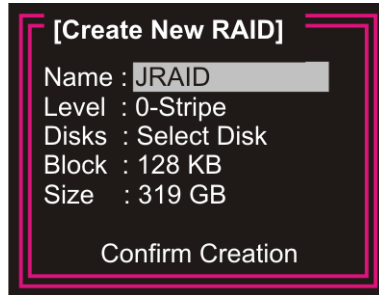

Figure D-4: Create RAID Name

Step 3: The **Level** item is then highlighted (**Figure D-5**). Press the **↑** or **↓** key to select the RAID level to create on the SATA drives, then press **ENTER**. Refer to **Section D.1.1** for supported configurations. Refer to **Section D.1.2** for RAID definitions.

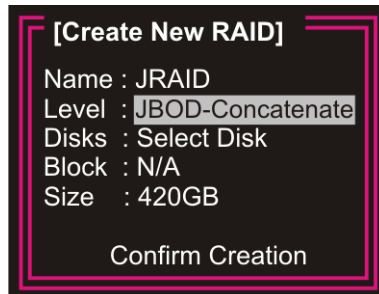
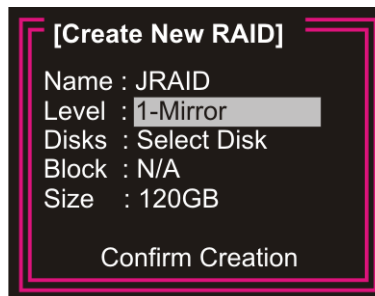
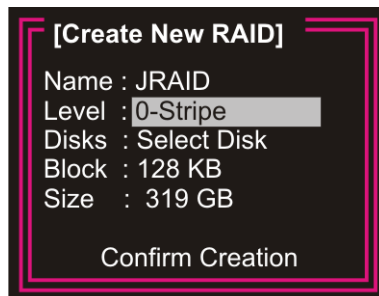

Figure D-5: Set the RAID Level

WSB-9452 PICMG 1.0 CPU Card

Step 4: The utility automatically selects the SATA drives installed. The selected disks are marked with a ► (Figure D-6).

Hard Disk Drive List			
	Model Name	Capacity	Type/Status
►	HDD0: ST3300622AS	300 GB	Non-RAID
►	HDD1: ST3120813AS	300 GB	Non-RAID

Figure D-6: Select disks

Step 5: Set the stripe block size for the RAID 0 set (Figure D-7). This parameter defines the size of the stripe written to each disk. If RAID 1 or JBOD was configured, **N/A** appears after this item. Choose from the following stripe size options:

- 4KB
- 8KB
- 16KB
- 32KB
- 64KB
- 128KB (DEFAULT)

[Create New RAID]

Name : JRAID

Level : 0-Stripe

Disks : Select Disk

Block : 128 KB

Size : 319 GB

Confirm Creation

Figure D-7: Set the stripe block size for RAID 0

Step 6: The **Size** item is then highlighted (**Figure D-8**). Enter the RAID volume size. The default value is the maximum volume size allowed.

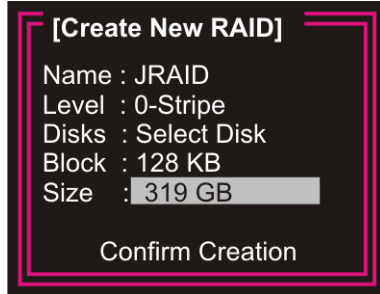

Figure D-8: Set the RAID volume size

Step 7: After the **ENTER** key is pressed, the **Confirm Creation** item is highlighted, and a confirmation message appears (**Figure D-9**). Press **Y** to confirm the creation of the RAID volume.

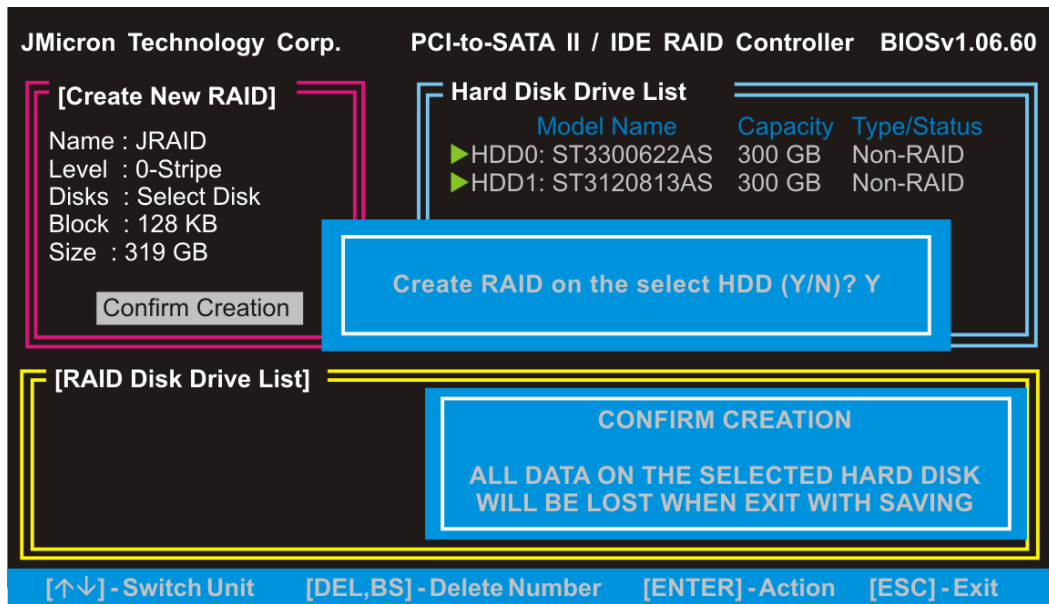

Figure D-9: Confirm creation



WARNING:

Pressing **Y** to confirm creation of the RAID volume destroys all the data in the SATA drives.

Step 8: Information about the created RAID volume appears in the RAID Disk Drive List window (**Figure D-10**).

RAID Disk Drive List					
	Model Name	RAID Level	Capacity	Status	Members (HDDx)
RDD0:	JRAID	0-Stripe	XXXGB	Normal	01

Figure D-10: RAID Disk Drive List

D.2.4.2 Delete a RAID volume

Step 1: In the RAID Setup Utility main menu, highlight **Delete RAID Disk Drive** (Figure D-11). Press **ENTER**.

[Main Menu]
Create RAID Disk Drive
Delete RAID Disk Drive
Revert HDD to Non-RAID
Solve Mirror Conflict
Rebuild Mirror Drive
Save and Exit Setup
Exit Without Saving

Figure D-11: Delete RAID Disk Drive

Step 2: The RAID volume in the RAID Disk Drive List is highlighted (**Figure D-12**).

Model Name	RAID Level	Capacity	Status	Members (HDDx)
RDD0: JRAID	0-Stripe	XXXGB	Normal	01

Figure D-12: RAID volume

Step 3: Press the space bar to select the RAID volume. The selected RAID volume is marked with a ►. Press the **Delete** key to delete the RAID volume.

Step 4: A confirmation message appears (**Figure D-13**). Press **Y** to confirm the deletion of the RAID volume.

JMicron Technology Corp. PCI-to-SATA II / IDE RAID Controller BIOSv1.06.60

[Main Menu]

- Create RAID Disk Drive
- Delete RAID Disk Drive
- Revert HDD to Non-RAID
- Solve Mirror Conflict
- Rebuild Mirror Drive
- Save and Exit
- Exit Without Save

[Hard Disk Drive List]

Model Name	Capacity	Type/Status
► HDD0: ST3300622AS	XXXGB	RAID Inside
► HDD1: ST3120813AS	XXXGB	RAID Inside

**ALL DATA ON THE RAID WILL BE LOST!!
ARE YOU SURE TO DELETE (Y/N)? Y**

[RAID Disk Drive List]

Model Name	RAID Level	Capacity	Status	Members (HDDx)
► RDD0: JRAID	0-Stripe	XXXGB	Normal	01

[↑↓] - Select RAID
 [SPACE] -Mark Delete
 [DEL] - Confirm
 [ESC] -Abort

Figure D-13: Delete RAID volume



WARNING:

Pressing **Y** to confirm deletion of the RAID volume converts the SATA drives to non-RAID and destroys all the data in the drives.

D.2.4.3 Revert an HDD to Non-RAID

An HDD that had been part of another RAID volume may still be used as a member of the RAID volume to be created. The HDD must first be reverted to non-RAID. Follow these steps to revert an HDD to non-RAID.



WARNING:

Reverting an HDD to non-RAID destroys all the data and previous RAID configurations in the HDD.

Step 5: In the RAID Setup Utility main menu, highlight **Revert HDD to Non-RAID** (Figure D-14). Press **ENTER**.



Figure D-14: Revert HDD to non-RAID

Step 1: Press the ↑ or ↓ key to select the HDD to be reverted to non-RAID, then press the spacebar to mark the HDD. The selected HDD is marked with a ►.

Step 2: A confirmation message appears (Figure D-15). Press Y to confirm the action.

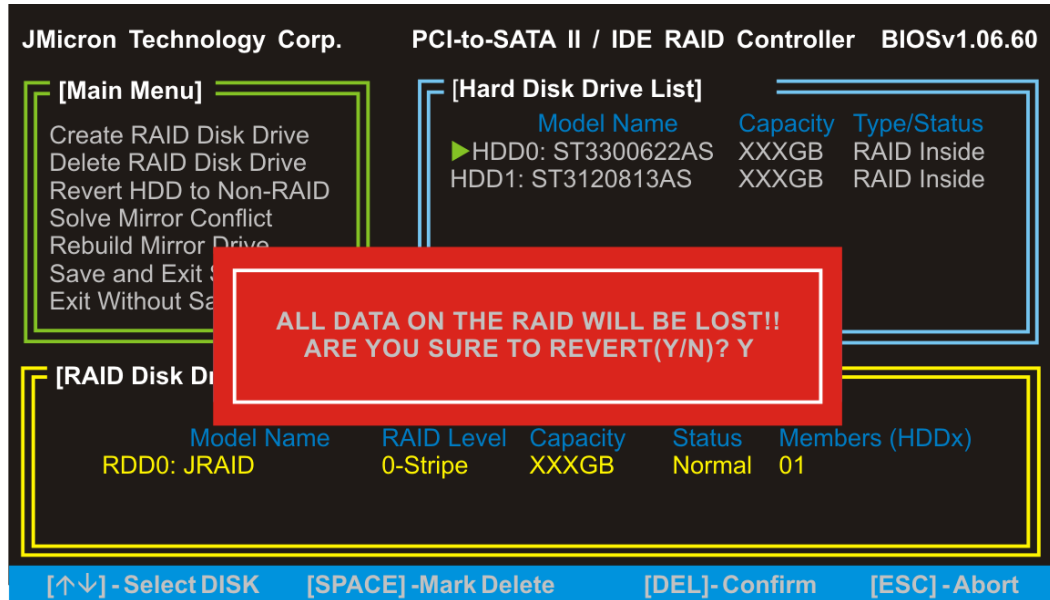

Figure D-15: Confirm revert HDD to non-RAID

Step 3: The reverted HDD is now listed as non-RAID (Figure D-16).

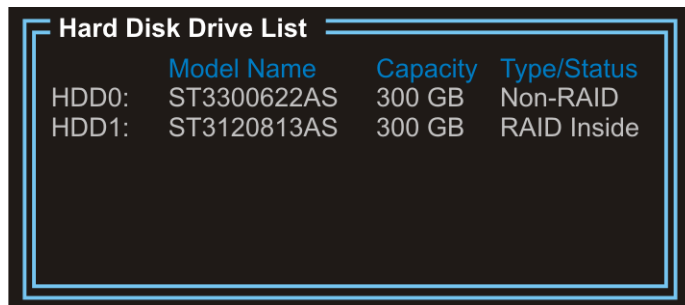

Figure D-16: Reverted HDD

D.2.4.4 Solve Mirror Conflict

A mirror conflict occurs when an HDD in a RAID 1 volume is unplugged from the system, then plugged in again. The system is unable to identify the source disk from which data will be mirrored. Use the **Solve Mirror Conflict** option to set the source disk and rebuild the mirror drive.

Step 1: In the RAID Setup Utility main menu, highlight Solve Mirror Conflict (Figure D-17). Press **ENTER**.



Figure D-17: Solve Mirror Conflict

Step 2: Press the **↑** or **↓** key to select the source disk, then press the spacebar to mark the HDD. The selected HDD is marked with a **▶**.

Step 3: Press the **Tab** key to go to the RAID Disk Drive list window.

Step 4: Press the spacebar to mark the RAID volume to be rebuilt.

Step 5: Press **ENTER** key to begin the rebuild process. A progress bar appears at the bottom of the screen to indicate the status of the rebuild process.

D.2.4.5 Rebuild Mirror Drive

A RAID 1 volume is broken when a member HDD fails. Use the **Rebuild Mirror** option to rebuild a RAID 1 volume after the faulty HDD is replaced.

Step 1: In the RAID Setup Utility main menu, highlight **Rebuild Mirror Drive** (Figure D-18). Press **ENTER**.

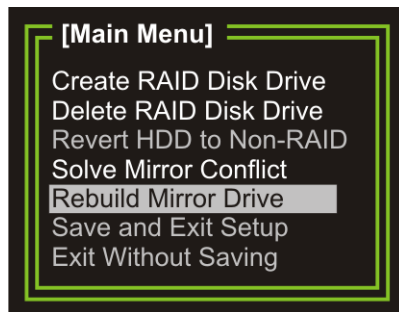

Figure D-18: Rebuild Mirror Drive

Step 2: Press the **↑** or **↓** key to select the source disk, then press the spacebar to mark the HDD. The selected HDD is marked with a **▶**.

Step 3: Press the **Tab** key to go to the RAID Disk Drive list window.

Step 4: Press the spacebar to mark the RAID volume to be rebuilt.

Step 5: Press **ENTER** to begin the rebuild process. A progress bar appears at the bottom of the screen to indicate the status of the rebuild process.

D.2.4.6 Save and Exit Setup

After the RAID configuration is complete, save the changes and exit the RAID configuration utility.

Step 1: In the RAID Setup Utility main menu, highlight **Save and Exit Setup** to effect all changes made (**Figure D-19**), then press **ENTER**.



Figure D-19: Save and Exit Setup

D.2.4.7 Exit without Saving

Step 1: To exit the RAID Setup Utility without saving the changes made, highlight **Exit without Saving** (**Figure D-20**), then press **ENTER**.



Figure D-20: Exit without Saving

D.2.5 Install the OS

Install the OS onto the SATA drives. To do this, follow the steps below.

Step 1: Insert the OS installation CD into the CD drive attached to the IDE device.

Step 2: Restart the system.

Step 3: When prompted, press **F6** to install the RAID controller device. Next, press **F2** to continue the installation.

Step 4: A message informs the user the OS is unable to determine the mass storage device installed on the system. At this point, insert the FDD with the copied RAID driver files into the FDD drive. The OS accesses the SATA drives through this disk.

Step 5: Next, select the driver for the OS being installed into the system. Once selected, press **ENTER**.

Step 6: The OS and the RAID drivers are then installed into the system. The SATA drives are configured as RAID drives as stipulated in the above selection.

The OS continues to be installed and the RAID on the SATA drives configured.

Appendix

E

Hazardous Materials Disclosure

E.1 Hazardous Material Disclosure Table for IPB Products Certified as RoHS Compliant Under 2002/95/EC Without Mercury

The details provided in this appendix are to ensure that the product is compliant with the Peoples Republic of China (China) RoHS standards. The table below acknowledges the presences of small quantities of certain materials in the product, and is applicable to China RoHS only.

A label will be placed on each product to indicate the estimated “Environmentally Friendly Use Period” (EFUP). This is an estimate of the number of years that these substances would “not leak out or undergo abrupt change.” This product may contain replaceable sub-assemblies/components which have a shorter EFUP such as batteries and lamps. These components will be separately marked.

Please refer to the table on the next page.

WSB-9452 PICMG 1.0 CPU Card

Part Name	Toxic or Hazardous Substances and Elements					
	Lead (Pb)	Mercury (Hg)	Cadmium (Cd)	Hexavalent Chromium (CR(VI))	Polybrominated Biphenyls (PBB)	Polybrominated Diphenyl Ethers (PBDE)
Housing	X	O	O	O	O	X
Display	X	O	O	O	O	X
Printed Circuit Board	X	O	O	O	O	X
Metal Fasteners	X	O	O	O	O	O
Cable Assembly	X	O	O	O	O	X
Fan Assembly	X	O	O	O	O	X
Power Supply Assemblies	X	O	O	O	O	X
Battery	O	O	O	O	O	O

O: This toxic or hazardous substance is contained in all of the homogeneous materials for the part is below the limit requirement in SJ/T11363-2006

X: This toxic or hazardous substance is contained in at least one of the homogeneous materials for this part is above the limit requirement in SJ/T11363-2006

此附件旨在确保本产品符合中国 RoHS 标准。以下表格标示此产品中某有毒物质的含量符合中国 RoHS 标准规定的限量要求。

本产品上会附有“环境友好使用期限”的标签，此期限是估算这些物质“不会有泄漏或突变”的年限。本产品可能包含有较短的环境友好使用期限的可替换元件，像是电池或灯管，这些元件将会单独标示出来。

部件名称	有毒有害物质或元素					
	铅 (Pb)	汞 (Hg)	镉 (Cd)	六价铬 (CR(VI))	多溴联苯 (PBB)	多溴二苯醚 (PBDE)
壳体	X	○	○	○	○	X
显示	X	○	○	○	○	X
印刷电路板	X	○	○	○	○	X
金属螺帽	X	○	○	○	○	○
电缆组装	X	○	○	○	○	X
风扇组装	X	○	○	○	○	X
电力供应组装	X	○	○	○	○	X
电池	○	○	○	○	○	○

○: 表示该有毒有害物质在该部件所有物质材料中的含量均在 SJ/T11363-2006 标准规定的限量要求以下。
X: 表示该有毒有害物质至少在该部件的某一均质材料中的含量超出 SJ/T11363-2006 标准规定的限量要求。

Index

A

AMI BIOS	106
anti-static precautions	26
anti-static pad	26
anti-static wristband	26
handling	26
self-grounding	26
AT power select jumper	97
location	98
settings	98

C

cables	
ATA 66/100 flat cable	27
dual port USB	28
dual RS-232	27
SATA drive	28
SATA drive power	28
Celeron® M CPU	12
Chipsets	
Intel® 945GM	12
Intel® ICH7-M	12
clear CMOS jumper	
location	99

D

Display	
DVI	15
VGA	15
D-SUB	104

E

electrostatic discharge	26
External Peripheral InterfaceConnectors	
LAN	71
Mini-DIN 6 PS/2	72
USB	73
VGA	74

G

GbE Ethernet	
BCM5787	18
Graphics Support	
Intel® GMA 950	14

I

IDE2, 5, 7, 13, 18, 19, 32, 49, 50, 90, 91, 109, 112, 113, 114, 115, 116, 117, 118, 148, 149, 172, 233, 246	
Intel® 945GM	6, 12, 14
Intel® Celeron® D	2, 10
Intel® Core™ Duo	2, 3, 6
Intel® Core™ Solo	2, 3, 6, 10, 11
Intel® Core™ 2 Duo	2, 3, 6, 10
Intel® ICH7-M	6, 12, 13, 22
Internal Peripheral Connectors	
ATX-12V Power Source	34
Audio Module	36
Backplane to Mainboard Power	37
Battery Connector	39
COM	61
CPU Fan	40

WSB-9452 PICMG 1.0 CPU Card

Digital Input/Output (DIO)	42	LVDS voltage selection jumper	
DVI	43	location	101
FDD Connector	45	M	
Front Panel	47	Memory support	
IDE	49	DDR2	17
Inverter	50	P	
IrDA Interface	52	PCI Express® Mini Card	3, 5
Keyboard	53	PICMG 1.0	2, 3
LVDS	55	power supply	
Parallel Port	56	AT power select jumper	97
PCI Express Mini Card	58	R	
SATA	63	RAID	232
TPM	65	RJ-45	72
TV Out	67	RoHS	3
USB	69	S	
J		SATA II	2, 3, 6, 18, 19, 20, 63, 92
Jmicron JMB363	232	Socket 478 CPU Installation	81
jumper		U	
AT power select	97	unpacking	26
LCD voltage selection	102	unpacking checklist	27
Jumpers		unpacking precautions	26
Clear CMOS	98	W	
LVDS LCD Voltage Selection	100	Watchdog Timer	211
L			
LCD display	102		
voltage select	102		
LCD voltage selection jumper	102		
location	103		
settings	102		