



MODEL:

SHIELD-156/185/215

Panel PC equips Intel® Amston Lake processor, Preinstalled with 8GB So-DIMM DDR5, PCAP touch, 304 Stainless Steel Chassis, With waterproof connectors Full Body IP69K, DC 10~28V Input.

User Manual

Revision

Date	Version	Changes
February 12, 2026	1.00	Initial release



Safety Instructions

- en** Warning! Read the user manual before connecting the system to the power source.
 - de** Vorsicht! Bitte lesen Sie die Bedienungsanleitung, bevor Sie das System an eine Stromquelle anschließen.
 - fr** Attention! Avant de brancher le système à la source d'alimentation, consultez le mode d'emploi.
 - it** Avvertenza! Consultare il manuale utente prima di collegare il sistema all'alimentatore.
 - es** Atención! Lea atentamente este manual del usuario antes de operar la fuente de alimentación.
 - zh** 警告! 在將系統連接到電源之前, 請仔細閱讀使用手冊。
 - cn** 警告! 在將系統連接到電源之前, 請仔細閱讀使用手冊。
-

- en** Warning! To prevent the system from overheating, do not operate it in an area that exceeds the maximum operating temperature described in the user manual.
 - de** Vorsicht! Um eine Überhitzung des Systems zu vermeiden, betreiben Sie es ausschließlich im zulässigen Betriebstemperaturbereich. Dieser ist in der Bedienungsanleitung vermerkt.
 - fr** Attention! Pour éviter la surchauffe du système, ne l'utilisez pas dans une zone dont la température dépasse les limites décrits dans le mode d'emploi.
 - it** Avvertenza! Per evitare che il sistema si surriscaldi, non utilizzarlo in aree che superino la temperatura massima d'esercizio descritta nel manuale utente.
 - es** Atención! Para evitar el excesivo calentamiento del sistema, no opere en las condiciones de temperatura superior a lo recomendado en este manual del usuario.
 - zh** 警告! 為防止系統過熱, 不要在超過使用手冊上記載的產品工作溫度範圍之外操作此系統。
 - cn** 警告! 為防止系統過熱, 不要在超過使用手冊上記載的產品工作溫度範圍之外操作此系統。
-

- en** Warning! Use only the adapter and power cord approved for this system. Use of another type of adapter may risk fire or explosion. Please refer to the user manual for the power adapter specifications.
- de** Vorsicht! Nur zugelassene Netzteile und Netzkabel dürfen verwendet werden. Die Benutzung von anderen Netzteilen kann einen Brand oder eine Explosion zur Folge haben. Prüfen Sie die jeweiligen Spezifikationen in der Bedienungsanleitung.
- fr** Attention! Utilisez exclusivement le câble d'alimentation et l'adaptateur homologués pour ce système. L'utilisation d'un autre type d'adaptateur risquerait de provoquer un incendie ou une explosion. Veuillez référer au mode d'emploi pour les spécifications de l'adaptateur d'alimentation.
- it** Avvertenza! Utilizzare solo l'adattatore e il cavo di alimentazione approvati per questo sistema. L'uso di un altro tipo di adattatore può causare rischio d'incendio o esplosione. Si prega di fare riferimento al manuale utente per le specifiche sull'alimentazione.
- es** Atención! Utilice solamente el adaptador de corriente alterna (CA) con Marcas Conformidad otorgadas. Cualquier otro adaptador no otorgado aumenta el riesgo de explosión o incendio. Por favor consulte el manual del usuario para las especificaciones del adaptador de alimentación.
- zh** 警告! 只能使用經過認證、適用於本系統的電源變壓器與電源線。使用不適用的電源變壓器將可能導致火災或爆炸。電源變壓器規格請參考使用手冊。
- cn** 警告! 只能使用经过认证, 适用于本系统的电源适配器与电源线。使用不适用的电源适配器将可能导致火灾或爆炸。电源适配器规格请参考使用手册。

-
- en** Warning! Ultimate disposal of this product should be handled according to all national laws and regulations.
- de** Vorsicht! Die Entsorgung dieses Produkts sollte gemäß allen Bestimmungen und Gesetzen des Landes erfolgen.
- fr** Attention! La mise au rebut ou le recyclage de ce produit sont généralement soumis aux lois et/ou directives de respect de l'environnement. Renseignez-vous auprès de l'organisme compétent.
- it** Avvertenza! Lo smaltimento di questo prodotto deve essere eseguito secondo le leggi e i regolamenti locali.
- es** Atención! La disposición final de residuos de este producto se debe cumplir con las normativas y leyes del país.
- zh** 警告! 本產品的廢棄處理應根據該國家的法律和規章進行。
- cn** 警告! 本产品的废弃处理应根据该国家的法律和规章进行。
-

Copyright

COPYRIGHT NOTICE

The information in this document is subject to change without prior notice in order to improve reliability, design and function and does not represent a commitment on the part of the manufacturer.

In no event will the manufacturer be liable for direct, indirect, special, incidental, or consequential damages arising out of the use or inability to use the product or documentation, even if advised of the possibility of such damages.

This document contains proprietary information protected by copyright. All rights are reserved. No part of this manual may be reproduced by any mechanical, electronic, or other means in any form without prior written permission of the manufacturer.

TRADEMARKS

All registered trademarks and product names mentioned herein are used for identification purposes only and may be trademarks and/or registered trademarks of their respective owners.

Manual Conventions



WARNING

Warnings appear where overlooked details may cause damage to the equipment or result in personal injury. Warnings should be taken seriously.



CAUTION

Cautionary messages should be heeded to help reduce the chance of losing data or damaging the product.



NOTE

These messages inform the reader of essential but non-critical information. These messages should be read carefully as any directions or instructions contained therein can help avoid making mistakes.



HOT SURFACE

This symbol indicates a hot surface that should not be touched without taking care.

Table of Contents

1 INTRODUCTION.....	15
1.1 OVERVIEW.....	16
1.2 MODEL VARIATIONS	16
1.3 FEATURES.....	17
1.4 FRONT PANEL.....	17
1.5 REAR PANEL	18
1.6 SYSTEM SPECIFICATIONS.....	19
1.7 DIMENSIONS.....	23
1.7.1 SHIELD-156 Dimensions.....	23
1.7.2 SHIELD-185 Dimensions.....	25
1.7.3 SHIELD-215 Dimensions.....	26
2 PACKING.....	27
2.1 ANTI-UNPACKING	28
2.2 PACKING LIST	29
2.3 OPTIONAL ITEMS.....	30
3 INSTALLATION	31
3.1 ANTI-STATIC PRECAUTIONS.....	32
3.2 INSTALLATION PRECAUTIONS.....	32
3.3 INSTALLATION AND CONFIGURATION STEPS	33
3.4 REMOVING THE BACK COVER	33
3.5 M.2 MODULE INSTALLATION.....	34
3.6 CLEAR CMOS.....	36
3.7 AT/ATX MODE SELECTION.....	36
3.7.1 AT Power Mode.....	37
3.7.2 ATX Power Mode.....	37
3.8 MOUNTING THE SYSTEM	38
3.8.1 YOKE Mounting.....	38
3.8.2 Arm Mounting	39
3.8.3 Stand Mounting.....	40

3.9 POWERING ON THE SYSTEM.....	41
3.10 SOFTWARE INSTALLATION	42
3.10.1 Driver Download	43
4 SYSTEM MAINTENANCE	45
4.1 SYSTEM MAINTENANCE INTRODUCTION	46
4.2 ANTI-STATIC PRECAUTIONS.....	46
4.3 TURN OFF THE POWER.....	47
4.4 REINSTALLING THE COVER.....	47
5 CONNECTORS	48
5.1 PERIPHERAL INTERFACE CONNECTORS.....	49
5.2 INTERNAL PERIPHERAL CONNECTORS	50
5.2.1 ME Override Connector (ME_FLASH1).....	50
5.2.2 LVDS Connector (LVDS1)	51
5.2.3 INVI Connector (INVI).....	51
5.2.4 LVDS1 Voltage Selection (J_PW1)	51
5.2.5 I ² C Connector (I2C1).....	52
5.2.6 USB Hub to Connector (USB1, TH_USB1, CAM_USB1).....	52
5.2.7 Power Button and LED Indicators (PWR_BTN1, CN1).....	53
5.2.8 Fan Connector (CPU_FAN1, CPU_FAN2)	53
5.2.9 Flash SPI ROM Connector (JBIOS1).....	53
5.2.10 SPI TPM Card Connector (CN2).....	54
5.2.11 M.2 E Key Slot (M2_A1)	54
5.2.12 M.2 M Key Slot (M2_M1, M2_M2)	55
5.2.13 M.2 B Key Slot (M2_B1).....	58
5.2.14 USB 3.0 to SFP Connector (J4).....	59
5.2.15 Power Connector (DCIN1).....	60
5.3 JUMPER SETTING.....	60
5.3.1 Clear CMOS Button (J_CMOS1).....	60
5.3.2 Auto Power Button Setting (J_ATX_AT1).....	60
5.3.3 RESET BTN (RST_BTN1).....	61
5.4 LVDS PANEL RESOLUTION SELECTION (SW1)	61
5.5 EXTERNAL INTERFACE PANEL CONNECTORS.....	61
5.5.1 COM1 RS-232 M12 Connector (COM1_M12).....	62

5.5.2	COM2 RS-232/422/485 M12 Connector (COM2_M12)	62
5.5.3	LAN1 M12 Connector (LAN1_M12)	63
5.5.4	LAN2 M12 Connector (LAN2_M12)	63
5.5.5	DIO M12 Connector (DIO_M12)	63
5.5.6	CAN M12 Connector (CAN_M12)	64
5.5.7	USB2.0 M12 Connector (USB20_M12)	64
5.5.8	USB3.0 M20 Connector (USB30_M12)	64
5.5.9	HDMI M20 Connector (HDMI_M12)	65
6	BIOS	66
6.1	INTRODUCTION	67
6.1.1	Starting Setup	67
6.1.2	Using Setup	68
6.1.3	Keyboard Navigation	68
6.1.3.1	Touch Navigation	70
6.1.4	Getting Help	71
6.1.5	Unable to Reboot after Configuration Changes	71
6.1.6	BIOS Menu Bar	71
6.2	MAIN	72
6.3	ADVANCED	74
6.3.1	CPU Configuration	76
6.3.2	Trusted Computing	79
6.3.3	iEi One Key Recovery 2	81
6.3.4	RTC Wake Settings	81
6.3.5	IT5571 Super IO Configuration	82
6.3.5.1	Serial Port 1 Configuration	83
6.3.5.2	Serial Port 2 Configuration	84
6.3.6	EC IT5571 H/W Monitor	86
6.3.6.1	Smart Fan Mode Configuration	87
6.3.7	Serial Port Console Redirection	89
6.3.7.1	Console Redirection Settings	90
6.3.8	NVMe Configuration (Optional)	93
6.3.9	SDIO Configuration	93
6.4	CHIPSET	95
6.4.1	System Agent (SA) Configuration	95

6.4.1.1 Memory Configuration	95
6.4.1.2 Graphics Configuration.....	96
6.4.1.3 VT-d	98
6.4.2 PCH-IO Configuration	99
6.4.2.1 PCI Express Configuration	102
6.4.2.2 M2_B1	102
6.4.2.3 M2_A1	104
6.4.2.4 M2_M2	105
6.4.2.5 M2_M1	106
6.4.2.6 SATA Configuration.....	107
6.4.2.7 HD Audio Configuration.....	108
6.4.2.8 SCS Configuration	109
6.5 SECURITY.....	111
6.6 BOOT.....	113
6.6.1 Boot Configuration	113
6.7 SAVE & EXIT	114
A REGULATORY COMPLIANCE	116
B SAFETY PRECAUTIONS	121
B.1 SAFETY PRECAUTIONS.....	122
B.1.1 General Safety Precautions	122
B.1.2 Anti-static Precautions	123
B.1.3 Product Disposal	124
B.2 MAINTENANCE AND CLEANING PRECAUTIONS	125
B.2.1 Maintenance and Cleaning.....	125
B.2.2 Cleaning Tools.....	126
C WATCHDOG TIMER	127
D HAZARDOUS MATERIALS DISCLOSURE	130
D.1.1 RoHS II Directive (2015/863/EU).....	131
D.1.2 China RoHS.....	132

List of Figures

Figure 1-1: SHIELD-156/185/215 Panel PC	16
Figure 1-2: Front View	18
Figure 1-3: Rear View	18
Figure 1-4: Rear Bottom Panel	19
Figure 1-5: SHIELD-156 Dimensions (mm)	24
Figure 1-6: SHIELD-185 Dimensions (mm)	25
Figure 1-7: SHIELD-215 Dimensions (mm)	26
Figure 3-1: Back Cover Retention Screws	34
Figure 3-2: Remove the Back Cover	34
Figure 3-3: M.2 Module Slot Location	35
Figure 3-4: M.2 Module Installation	36
Figure 3-5: Clear CMOS Button Location	36
Figure 3-6: AT/ATX Switch Location	37
Figure 3-7: Yoke-mounting Bracket	38
Figure 3-8: Arm Mounting Retention Screw Holes	39
Figure 3-9: Arm Mounting	40
Figure 3-10: Stand Mounting (Stand-Cxx)	41
Figure 3-11: Power Button	42
Figure 3-12: IEI Resource Download Center	42
Figure 5-1: Main Board Layout Diagram (Front Side)	49
Figure 5-2: I/O Board Layout Diagram	49
Figure 6-1: BIOS Starting Menu	68
Figure 6-2: On-screen Navigation Keys	70
Figure 6-3: BIOS Main (1/3)	72
Figure 6-4: BIOS Main (2/3)	73
Figure 6-5: BIOS Main (3/3)	73
Figure 6-6: BIOS Advanced	75
Figure 6-7: CPU Configuration (1/2)	76
Figure 6-8: CPU Configuration (2/2)	77
Figure 6-9: Trusted Computing	79
Figure 6-10: iEi One Key Recovery 2	81

Figure 6-11: RTC Wake Settings	82
Figure 6-12: IT5571 Super IO Configuration	83
Figure 6-13: Serial Port 1 Configuration.....	84
Figure 6-14: Serial Port 2 Configuration.....	85
Figure 6-15: EC IT5571 H/W Monitor	86
Figure 6-16: Smart Fan Mode Configuration (1/2)	87
Figure 6-17: Smart Fan Mode Configuration (2/2)	88
Figure 6-18: Serial Port Console Redirection	90
Figure 6-19: Console Redirection Settings	91
Figure 6-20: NVMe Configuration	93
Figure 6-21: SDIO Configuration	94
Figure 6-22: System Agent (SA) Configuration	95
Figure 6-23: Memory Configuration.....	96
Figure 6-24: Graphics Configuration	97
Figure 6-25: VT-d.....	99
Figure 6-26: PCH-IO Configuration (1/2).....	99
Figure 6-27: PCH-IO Configuration (2/2).....	100
Figure 6-28 PCI Express Configuration.....	102
Figure 6-29: M2_B1	103
Figure 6-30: M2_A1	104
Figure 6-31: M2_M2.....	105
Figure 6-32: M2_M1.....	106
Figure 6-33: SATA Configuration	107
Figure 6-34: HD Audio Configuration	108
Figure 6-35: SCS Configuration	109
Figure 6-36: Security (1/2).....	111
Figure 6-37: Security (2/2).....	112
Figure 6-38: Boot	113
Figure 6-39: Save & Exit.....	114

List of Tables

Table 1-1: Model Variation	17
Table 1-2: System Specifications (1/2)	21
Table 1-3: System Specifications (2/2)	23
Table 5-1: Peripheral Interface Connectors	50
Table 5-2: ME Override Connector (ME_FLASH1) Pinouts	50
Table 5-3: LVDS Connector (LVDS1) Pinouts	51
Table 5-4: INV1 Connector (INV1) Pinouts	51
Table 5-5: LVDS1 Voltage Selection Pinouts	52
Table 5-6: I ² C Connector (I2C1) Pinouts	52
Table 5-7: USB Hub to Connector (USB1) Pinouts	52
Table 5-8: USB Hub to Connector (TH_USB1) Pinouts	52
Table 5-9: USB Hub to Connector (CAM_USB1) Pinouts	52
Table 5-10: Power Button and LED Indicators (PWR_BTN1) Pinouts	53
Table 5-11: Power Button and LED Indicators (CN1) Pinouts	53
Table 5-12: Fan Connector (CPU_FAN1, CPU_FAN2) Pinouts	53
Table 5-13: Flash SPI ROM Connector (JBIOS1) Pinouts	53
Table 5-14: SPI TPM Card Connector (CN2) Pinouts	54
Table 5-15: M.2 E Key Slot (M2_A1) Pinouts	55
Table 5-16: M.2 M Key Slot (M2_M1) Pinouts	57
Table 5-17: M.2 M Key Slot (M2_M2) Pinouts	58
Table 5-18: M.2 B Key Slot (M2_B1) Pinouts	59
Table 5-19: USB 3.0 to SFP Connector (J4) Pinouts	59
Table 5-20: Power Connector (DCIN1) Pinouts	60
Table 5-21: Jumper Setting	60
Table 5-22: Auto Power Button Setting (J_ATX_AT1)	60
Table 5-23: Backlight Enable Selection (J_BL_EN)	61
Table 5-24: LVDS Resolution Selection (SW1) Settings	61
Table 5-25: External Interface Panel Connectors	62
Table 5-26: COM1 RS-232 M12 Connector (COM1_M12) Pinouts	62
Table 5-27: COM2 RS-232/422/485 M12 Connector (COM2_M12) Pinouts	62
Table 5-28: LAN1 M12 Connector (LAN1_M12) Pinouts	63

Table 5-29: LAN2 M12 Connector (LAN2_M12) Pinouts	63
Table 5-30: DIO M12 Connector (DIO_M12) Pinouts	63
Table 5-31: CAN M12 Connector (CAN_M12) Pinouts	64
Table 5-32: USB2.0 M12 Connector (USB20_M12) Pinouts	64
Table 5-33: USB3.0 M20 Connector (USB30_M12) Pinouts	64
Table 5-34: HDMI M20 Connector (HDMI_M12) Pinouts.....	65
Table 6-1: BIOS Navigation Keys	69
Table 6-2: BIOS On-screen Navigation Keys	70

Chapter

1

Introduction

1.1 Overview



Figure 1-1: SHIELD-156/185/215 Panel PC

The SHIELD-156/185/215 is an Intel® Amston Lake Processor panel PC with a rich variety of functions and peripherals.

The Intel® Amston Lake Processor is a SoC (System-on-Chip) that ensures optimal memory, graphics, and peripheral I/O support. The system comes with 8GB DDR5 RAM ensuring smooth data throughputs with reduced bottlenecks and fast system access.

Two 2.5Gbps LAN and one 1Gbps LAN ensure simplified connectivity to a variety of external peripheral devices. And it also has one CANBUS with 2.0KV isolation.

1.2 Model Variations

The model number and model variation are listed below.

Model	Size	CPU
SHIELD-156-R3C-R10	15.6"	Intel® Atom x7433RE
SHIELD-185-R3C-R10	18.5"	
SHIELD-215-R3C-R10	21.5"	

SHIELD-156/185/215

SHIELD-156-R4C-R10	15.6"	Amston Lake X7835RE
SHIELD-185-R4C-R10	18.5"	
SHIELD-215-R4C-R10	21.5"	

Table 1-1: Model Variation

1.3 Features

The SHIELD-156/185/215 features are listed below:

- Intel® Amston Lake Processor
- High-Speed Transmission Optical Fiber Module
- Corrosion-resistant waterproof 304 stainless-steel housing
- Equipped with DDR5 memory for higher bandwidth and lower power consumption
- Durable PCAP touchscreen designed for reliable operation in harsh environments
- Multiple onboard interfaces support high-speed storage and module expansion
- Full body IP69K

1.4 Front Panel

The front side of the SHIELD-156/185/215 is a panel LCD touchscreen (**Figure 1-2**).



Figure 1-2: Front View

1.5 Rear Panel

The rear panel provides access to retention screw holes that support VESA 100 mounting. See **Figure 1-3**.

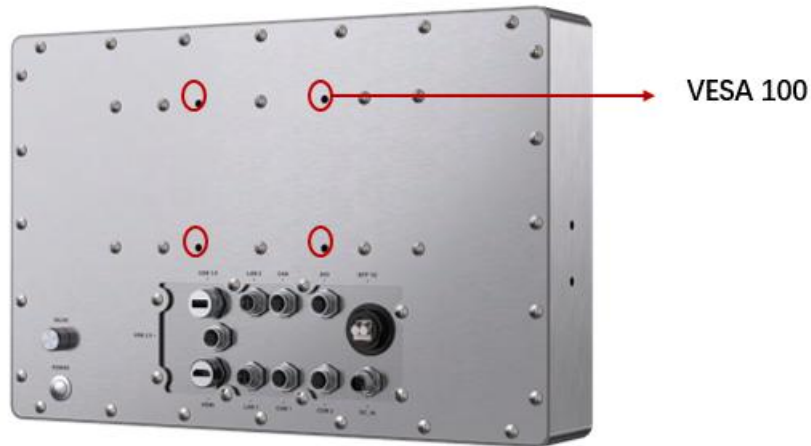

Figure 1-3: Rear View

The rear panel of the SHIELD-156/185/215 has the following connectors and switches.

SHIELD-156/185/215

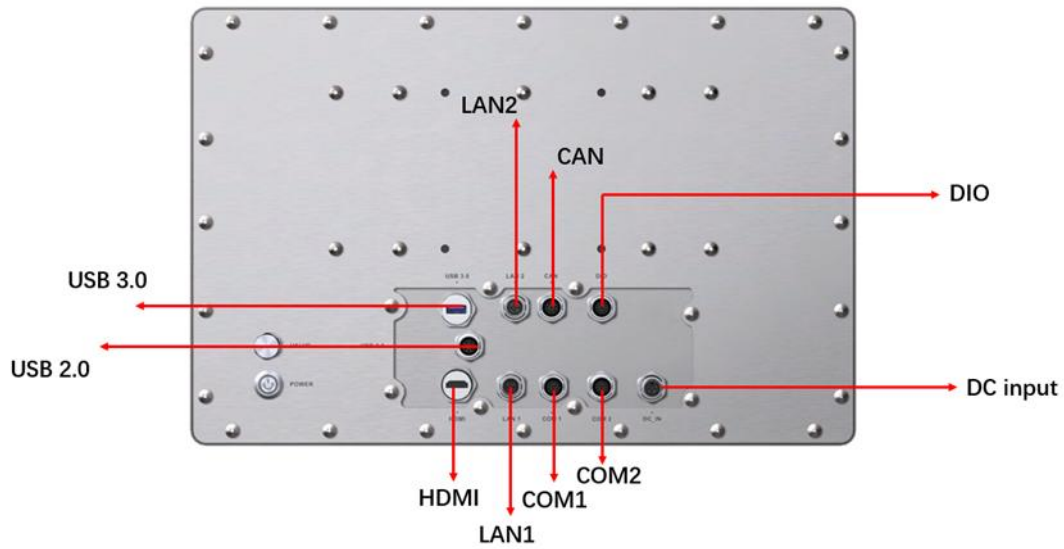

Figure 1-4: Rear Bottom Panel

1.6 System Specifications

The technical specifications for the SHIELD-156/185/215 systems are listed in **Table 1-2** & **Table 1-3**.

Specification	SHIELD-156-R3C-R10	SHIELD-185-R3C-R10	SHIELD-215-R3C-R10
LCD Size	15.6" (16:9)	18.5" (16:9)	21.5" (16:9)
Max. Resolution	1920 x 1080	1920 x 1080	1920 x 1080
Brightness (cd/m ²)	450	500	500
LCD Color	16.2M	16.7M	16.7M
Pixel Pitch (mm)	0.179 (H) x 0.179 (V)	0.213 (H) x 0.213 (V)	0.248 (H) x 0.248 (V)
Contrast Ratio	800:1	1000:1	1000:1
Viewing Angle (H-V)	178°/178°	178°/178°	178°/178°
Backlight MTBF	50000 hours	50000 hours	50000 hours
Touchscreen	Multi-point projected capacitive type		

	(anti-UV / anti-glare coating, support gloves) Surface hardness: $\geq 7H$	
Touch Controller	Projected capacitive type: ILI2520	Projected capacitive type: ILI2521
CPU (SoC)	Intel Atom® x7433RE Processor 6M Cache, up to 3.40 GHz / TDP 9w	
RAM	1 x SO-DIMM DDR5-4800 up to 16GB (pre-installed 8GB)	
Ethernet	2 x 2.5GbE LAN via Intel I226-IT	
Storage	1 x M-Key 2280 (PCIe Gen3 x2) for M.2 SSD 1 x 128GB eMMC (optional)*	
Expansion	1 x M.2 M-Key 2242/2280 (PCIe Gen3 x1 + SATA) 1 x M.2 B-Key 3052/3080 (PCIe Gen3 x1 + USB 3.0 x1) 1 x NANO-SIM 1 x M.2 A-key 2230 (PCIe Gen3 x1 + USB 2.0 x1)	
Camera	1 x Camera (Wide-viewing angle)	
I/O Interface	M12 Waterproof Connector for 2 x RJ-45 2.5GbE LAN M12 Waterproof Connector for 1 x RS-232(with 2.0 kV isolation) M12 Waterproof Connector for 1 x RS-232/422/485(with 2.0 kV isolation) M12 Waterproof Connector for 1 x CANBUS (with 2.0 kV isolation) M12 Waterproof Connector for 1 x 8bit DIO (Isolator) (with 1.6 KV isolation) with SMBus M12 Waterproof Connector for 1 x USB2.0 M20 Waterproof Connector for 1 x USB3.0 M20 Waterproof Connector for 1 x HDMI 1.4b Waterproof Connector for Power switch M12 Waterproof Connector for DC Input Power	

SHIELD-156/185/215

Construction	304 Stainless Steel Chassis
Mounting	VESA Mount 100 x 100 and Pole mount and YOKE
Operating Temperature	-30°C~55°C@50%RH
Storage Temperature	-40°C~70°C
Humidity	10 to 90%RH @ 40°C, non-condensing
IP Level	Full body IP69K
Safety/EMC	CE/FCC
Power Input	DC 10~28V
OS	Windows 10/11 IoT Enterprise 64-bit Linux

Table 1-2: System Specifications (1/2)

Specification	SHIELD-156-R4C-R10	SHIELD-185-R4C-R10	SHIELD-215-R4C-R10
LCD Size	15.6" (16:9)	18.5" (16:9)	21.5" (16:9)
Max. Resolution	1920 x 1080	1920 x 1080	1920 x 1080
Brightness (cd/m²)	450	500	500
LCD Color	16.2M	16.7M	16.7M
Pixel Pitch (mm)	0.179 (H) x 0.179 (V)	0.213 (H) x 0.213 (V)	0.248 (H) x 0.248 (V)
Contrast Ratio	800:1	1000:1	1000:1
Viewing Angle (H-V)	178°/178°	178°/178°	178°/178°
Backlight MTBF	50000 hours	50000 hours	50000 hours
Touchscreen	Multi-point projected capacitive type (anti-UV / anti-glare coating, support gloves) Surface hardness: ≥7H		
Touch Controller	Projected capacitive type:	Projected capacitive type: ILI2521	

	ILI2520
CPU (SoC)	Intel Atom® x7835RE Processor 6M Cache, up to 3.40 GHz / TDP 12w
RAM	1 x SO-DIMM DDR5-4800 up to 16GB (pre-installed 8GB)
Ethernet	2 x 2.5GbE LAN via Intel I226-IT
Storage	1 x M-Key 2280 (PCIe Gen3 x2) for M.2 SSD 1 x 128GB eMMC (optional)*
Expansion	1 x M.2 M-Key 2242/2280 (PCIe Gen3 x1 + SATA) 1 x M.2 B-Key 3052/3080 (PCIe Gen3 x1 + USB 3.0 x1) 1 x NANO-SIM 1 x M.2 A-key 2230 (PCIe Gen3 x1 + USB 2.0 x1)
Camera	1 x Camera (Wide-viewing angle)
I/O Interface	M12 Waterproof Connector for 2 x RJ-45 2.5GbE LAN M12 Waterproof Connector for 1 x RS-232(with 2.0 kV isolation) M12 Waterproof Connector for 1 x RS-232/422/485(with 2.0 kV isolation) M12 Waterproof Connector for 1 x CANBUS (with 2.0 kV isolation) M12 Waterproof Connector for 1 x 8bit DIO (Isolator) (with 1.6 KV isolation) with SMBus M12 Waterproof Connector for 1 x USB2.0 M20 Waterproof Connector for 1 x USB3.0 M20 Waterproof Connector for 1 x HDMI 1.4b Waterproof Connector for Power switch M12 Waterproof Connector for DC Input Power
Construction	304 Stainless Steel Chassis
Mounting	VESA Mount 100 x 100 and Pole mount and YOKE
Operating Temperature	-30°C~55°C@50%RH

SHIELD-156/185/215

Storage Temperature	-40°C~70°C
Humidity	10 to 90%RH @ 40°C, non-condensing
IP Level	Full body IP69K
Safety/EMC	CE/FCC
Power Input	DC 10~28V
OS	Windows 10/11 IoT Enterprise 64-bit Linux

Table 1-3: System Specifications (2/2)

1.7 Dimensions

The SHIELD-156/185/215 dimensions are shown below.

1.7.1 SHIELD-156 Dimensions

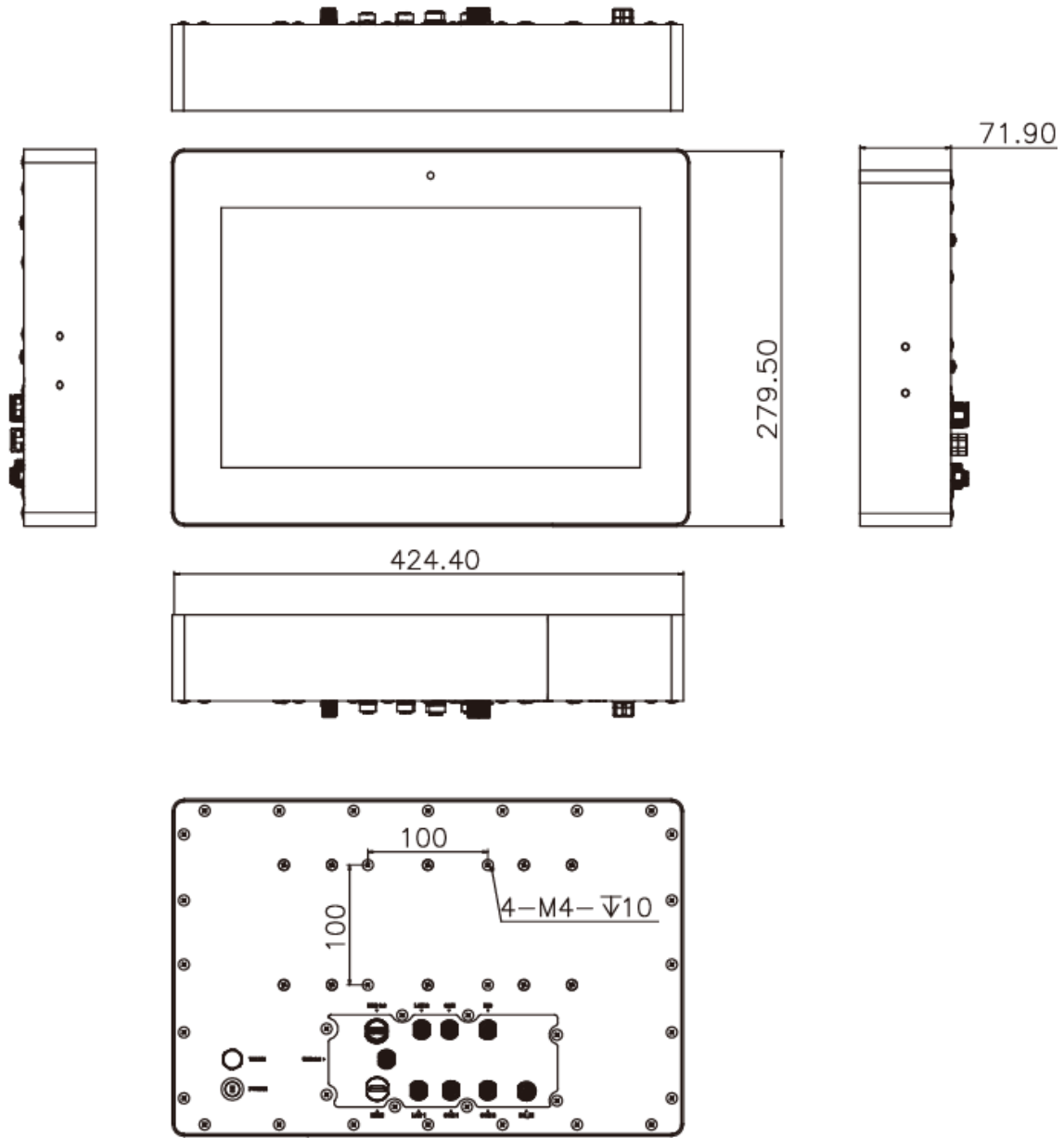

Figure 1-5: SHIELD-156 Dimensions (mm)

SHIELD-156/185/215

1.7.2 SHIELD-185 Dimensions

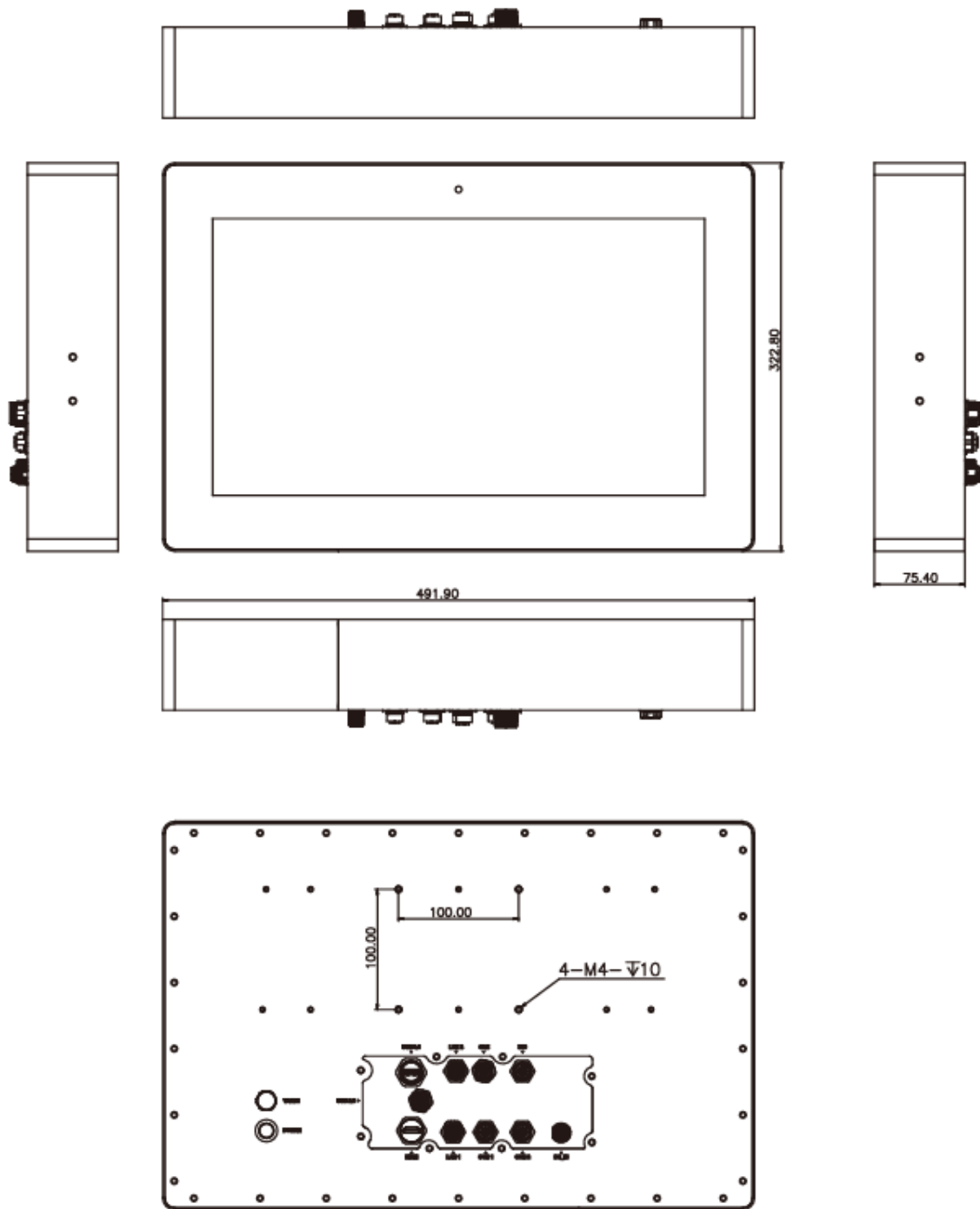

Figure 1-6: SHIELD-185 Dimensions (mm)

1.7.3 SHIELD-215 Dimensions

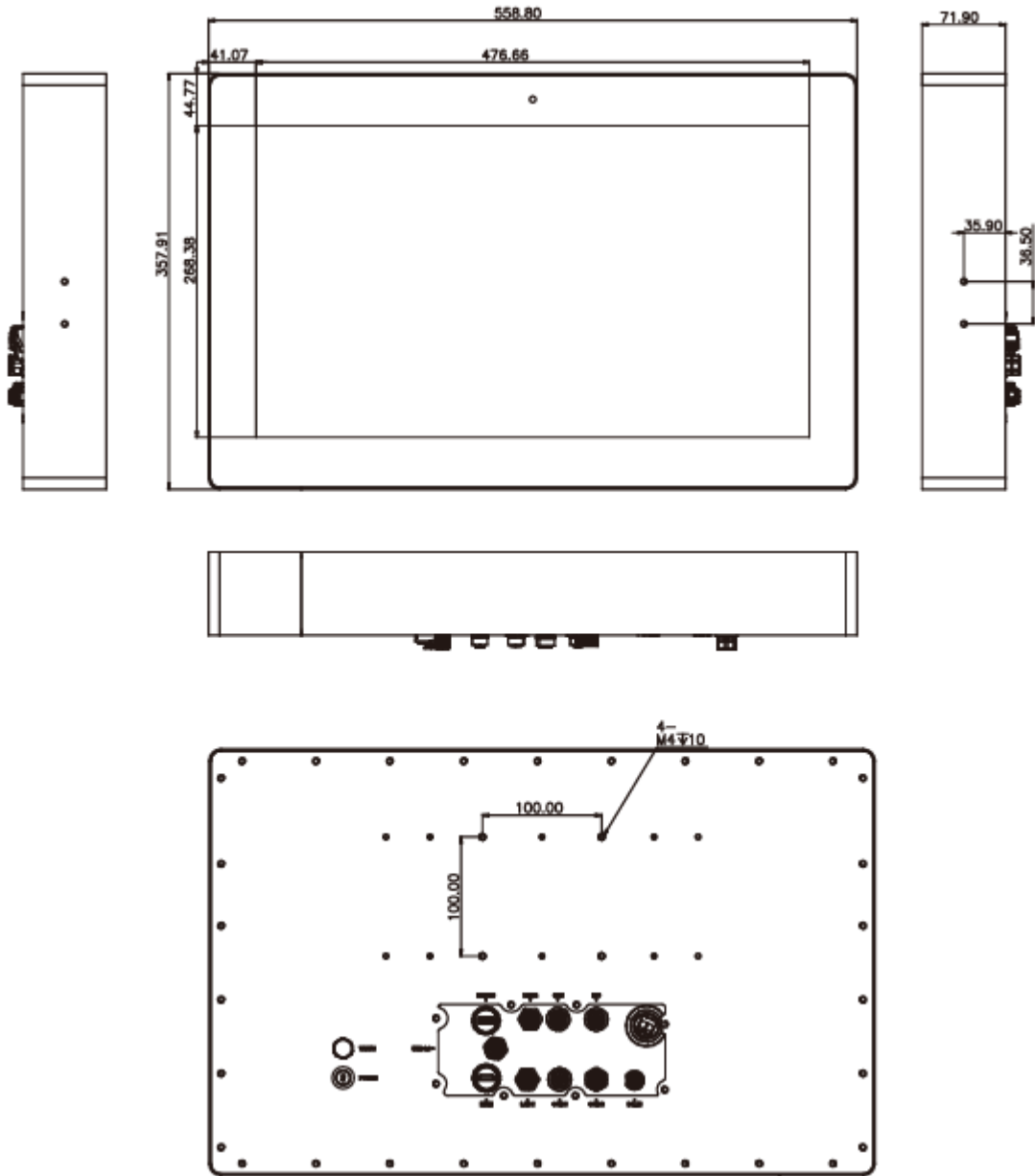

Figure 1-7: SHIELD-215 Dimensions (mm)

Chapter

2

Packing

2.1 Anti-Unpacking

To unpack the panel PC, follow the steps below:



WARNING!

The front side LCD screen has a protective plastic cover stuck to the screen. Only remove the plastic cover after the panel PC has been properly installed. This ensures the screen is protected during the installation process.

Step 1: Open the box.

Step 2: Lift the monitor out of the boxes.

Step 3: Remove both polystyrene ends, one from each side.

Step 4: Pull the plastic cover off the panel PC.

Step 5: Make sure all the components listed in the packing list are present.

SHIELD-156/185/215**2.2 Packing List****NOTE:**

If any of the components listed in the checklist below are missing, do not proceed with the installation. Contact the IEI reseller or vendor the SHIELD-156/185/215 was purchased from or contact an IEI sales representative directly by sending an email to sales@ieiworld.com.

The SHIELD-156/185/215 panel PC is shipped with the following components:

Quantity	Item
1	SHIELD-156/185/215 panel PC
1	Power Cable
1	USB 2.0 Cable (M12 to USB Type-A)
1	LAN Cable (M12 to RJ45 female)

2.3 Optional Items

The following are optional components which may be separately purchased:

Item and Part Number
LAN Cable
USB2.0 Cable (M12 to USB Type-A female X2)
DIO Cable (M12 to HDB15 Male)
COM Cable (M12 to DB9 Male)
CAN Cable (M12 to DB9 Male)
USB3.0 Cable (Waterproof Type-A Male to USB Type-A female)
HDMI CABLE (waterproof Type-A Male to HDMI Type-A female)
YOKE MOUNT
SCREW
Optical Fiber Module

If any of these items are missing or damaged, contact the distributor or sales representative immediately.

Chapter

3

Installation

3.1 Anti-static Precautions

**WARNING:**

Failure to take ESD precautions during the maintenance of the SHIELD-156/185/215 may result in permanent damage to the SHIELD-156/185/215 and severe injury to the user.

Electrostatic discharge (ESD) can cause serious damage to electronic components, including the SHIELD-156/185/215. Dry climates are especially susceptible to ESD. It is therefore critical that whenever SHIELD-156/185/215 is accessed internally, or any other electrical component is handled, the following anti-static precautions are strictly adhered to.

- **Wear an anti-static wristband:** Wearing a simple anti-static wristband can help to prevent ESD from damaging the board.
- **Self-grounding:** Before handling the board, touch any grounded conducting material. During the time the board is handled, frequently touch any conducting materials that are connected to the ground.
- **Use an anti-static pad:** When configuring the SHIELD-156/185/215, place it on an anti-static pad. This reduces the possibility of ESD damaging the SHIELD-156/185/215.
- **Only handle the edges of the PCB:** When handling the PCB, hold the PCB by the edges.

3.2 Installation Precautions

When installing the panel PC, please follow the precautions listed below:

- **Power turned off:** When installing the panel PC, make sure the power is off. Failing to turn off the power may cause severe injury to the body and/or damage to the system.
- **Certified Engineers:** Never open the equipment. For safety reasons, the equipment should be opened only by qualified skilled person. Only certified engineers should install and modify onboard functionalities.

SHIELD-156/185/215

- **Anti-static Discharge:** If a user opens the rear panel of the panel PC, to configure the jumpers or plug in added peripheral devices, ground themselves first and wear an anti-static wristband.

3.3 Installation and Configuration Steps

The following installation steps must be followed.

Step 1: Unpack the panel PC.

Step 2: Install a M.2 module.

Step 3: Configure the system.

Step 4: Connect peripheral devices to the panel PC.

Step 5: Mount the panel PC.

3.4 Removing the Back Cover



WARNING:

Before any internal installation procedures are carried out on the system, make sure the system is turned off and cooled down for 15 minutes. Failing to turn off the system before opening it can cause permanent damage to the system and serious or fatal injury to the user.

To access the SHIELD-156/185/215 internally the back cover must be removed. To remove the back cover, please follow the steps below.

Step 1: Remove all retention screws from the back cover (**Figure 3-1**).

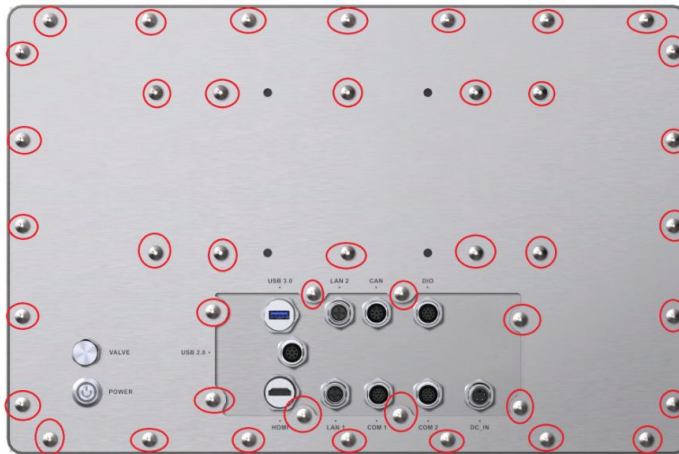

Figure 3-1: Back Cover Retention Screws

Step 2: Gently lift the rear cover upwards to separate it. Pay attention to the switch wire interface. Unplug the switch wire and remove the rear cover. See **Figure 3-2**.

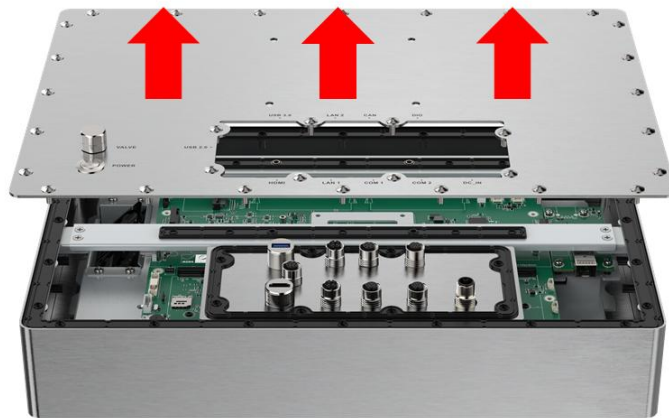

Figure 3-2: Remove the Back Cover

3.5 M.2 Module Installation

To install a M.2 module into the SHIELD-156/185/215, please follow the steps below:

SHIELD-156/185/215

- Step 1:** Remove the back cover. See **Section 3.4** above.
- Step 2:** Locate the M.2 card slot. Remove the preinstalled retention screw on the standoff of the M.2 card slot as shown in **Figure 3-3**.

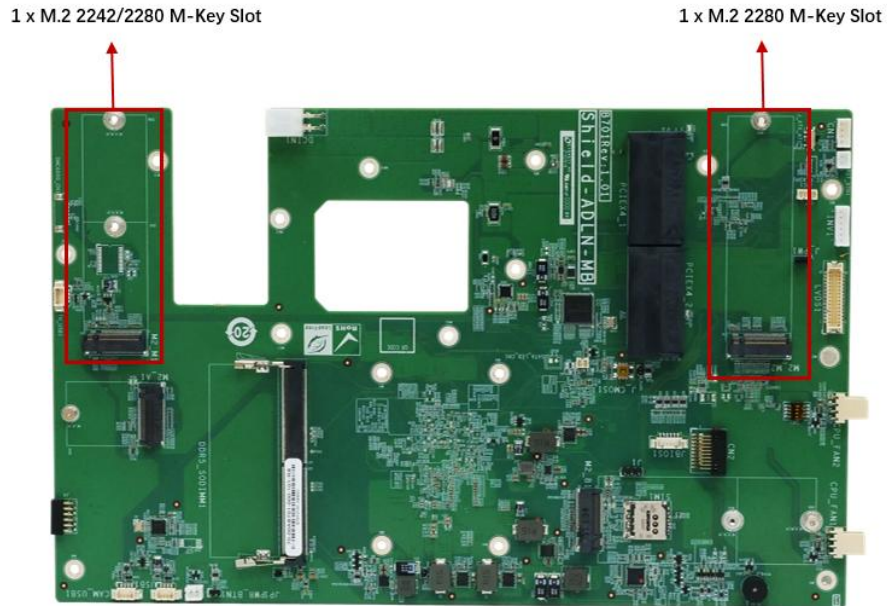

Figure 3-3: M.2 Module Slot Location

- Step 3:** Line up the notch on the M.2 module with the notch on the connector. Slide the M.2 module into the socket at an angle of about 20°.
- Step 4:** Secure the M.2 module with the retention screw. Push the other end of the M.2 module down and secure the module with the previously removed retention screw (**Figure 3-4**).

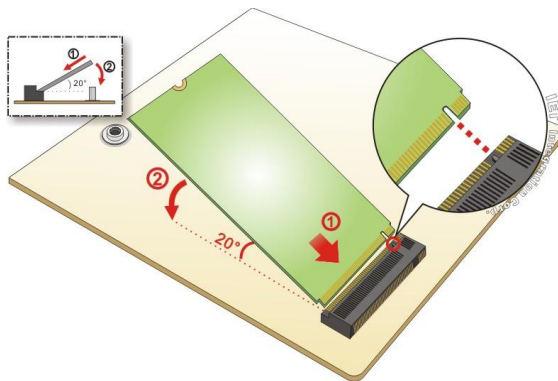

Figure 3-4: M.2 Module Installation

Step 5: Connect the switch wire, close the rear cover, and secure it with the fixing screws.

3.6 Clear CMOS

If the SHIELD-156/185/215 fails to boot due to improper BIOS settings, the clear CMOS jumper clears the CMOS data and resets the system BIOS information. To do this, push the clear CMOS button for three seconds, then restart the system. The clear CMOS button location is shown in **Figure 3-5**.

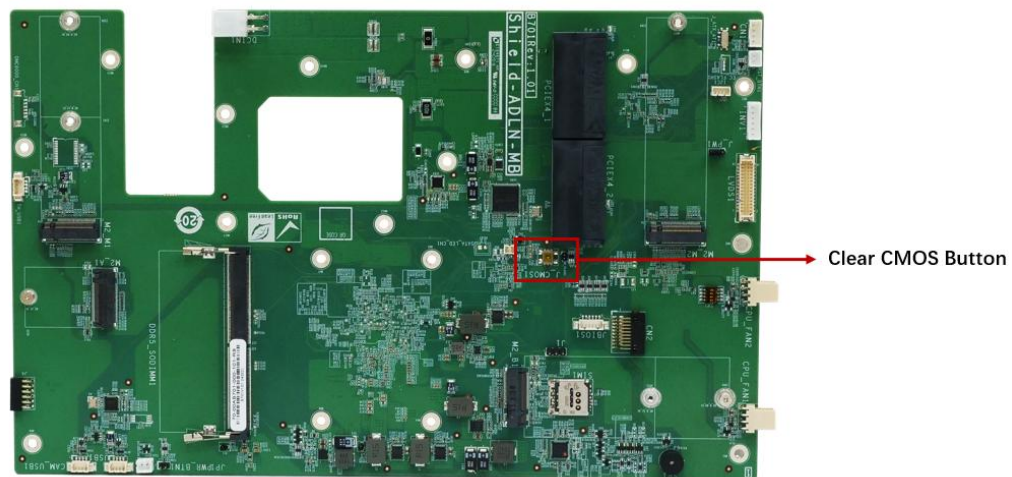

Figure 3-5: Clear CMOS Button Location

3.7 AT/ATX Mode Selection

AT or ATX power mode can be used on the SHIELD-156/185/215. The selection is made through an AT/ATX switch located on the bottom panel (**Figure 3-6**).

SHIELD-156/185/215

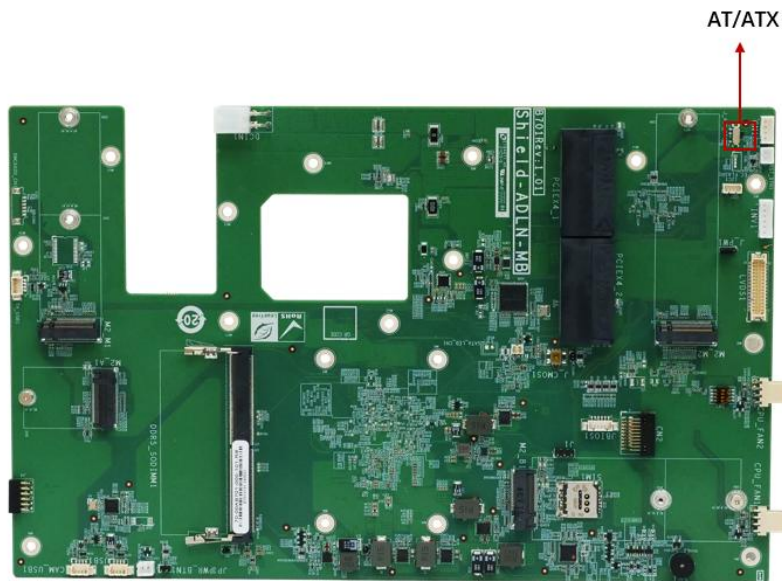

Figure 3-6: AT/ATX Switch Location

3.7.1 AT Power Mode

With the AT mode selected, the power is controlled by a central power unit rather than a power switch. The SHIELD-156/185/215 panel PC turns on automatically when the power is connected. The AT mode benefits a production line to control multiple panel PCs from a central management center and other applications including:

- ATM
- Self-service kiosk
- Plant environment monitoring system
- Factory automation platform
- Manufacturing shop flow

3.7.2 ATX Power Mode

With the ATX mode selected, the SHIELD-156/185/215 panel PC goes in a standby mode when it is turned off. The panel PC can be easily turned on via network or a power switch in standby mode. Remote power control is perfect for advertising applications since the broadcasting time for each panel PC can be set individually and controlled remotely. Other possible application includes:

- Security surveillance
- Point-of-Sale (POS)
- Advertising terminal

3.8 Mounting the System

The methods of mounting the SHIELD-156/185/215 are listed below.

- YOKE mounting
- Arm mounting
- Stand mounting

The mounting methods are described below.

3.8.1 YOKE Mounting



Figure 3-7: Yoke-mounting Bracket

SHIELD-156/185/215

3.8.2 Arm Mounting

The SHIELD-156/185/215 is VESA (Video Electronics Standards Association) compliant and can be mounted on an arm with a 100 mm interface pad. To mount the SHIELD-156/185/215 on an arm, please follow the steps below.

Step 1: The arm is not provided by our company. Please correctly mount the arm onto the surface it uses as a base. To do this, refer to the installation documentation that came with the mounting arm.



NOTE:

When purchasing the arm please ensure that it is VESA compliant and that the arm has a 100 mm interface pad. If the mounting arm is not VESA compliant it cannot be used to support the SHIELD-156/185/215 panel PC.

Step 2: Once the mounting arm has been firmly attached to the surface, lift the panel PC onto the interface pad of the mounting arm.

Step 3: Align the retention screw holes on the mounting arm interface with those in the panel PC (**Figure 3-8**).

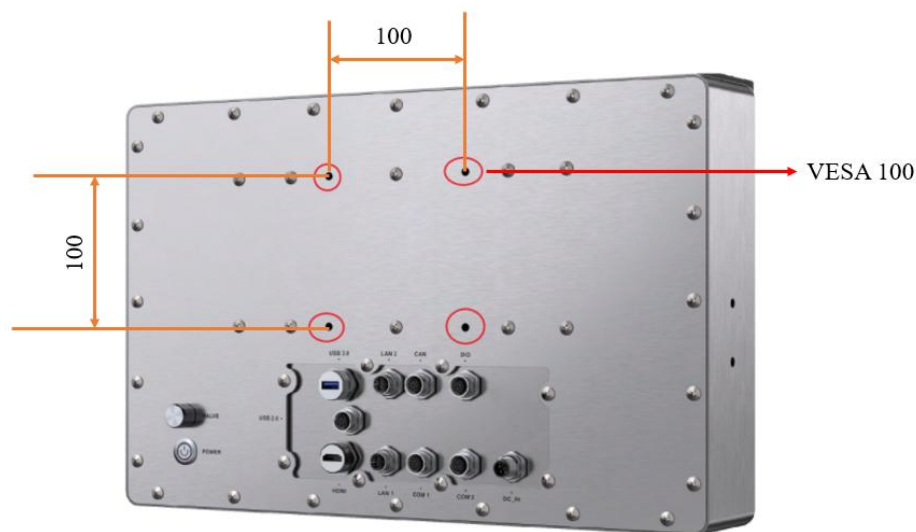

Figure 3-8: Arm Mounting Retention Screw Holes

Step 4: Secure the SHIELD-156/185/215 to the interface pad by inserting four retention screws through the mounting arm interface pad and into the SHIELD-156/185/215.

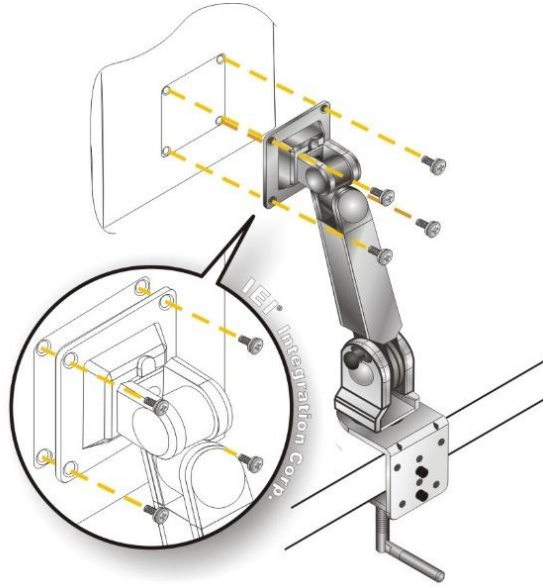

Figure 3-9: Arm Mounting

3.8.3 Stand Mounting

To mount the SHIELD-156/185/215 using the stand mounting kit (Not available), please follow the steps below.

- Step 1:** Locate the screw holes on the rear of the SHIELD-156/185/215. This is where the bracket will be attached.
- Step 2:** Align the bracket with the screw holes.
- Step 3:** To secure the bracket to the SHIELD-156/185/215 insert the retention screws into the screw holes and tighten them.

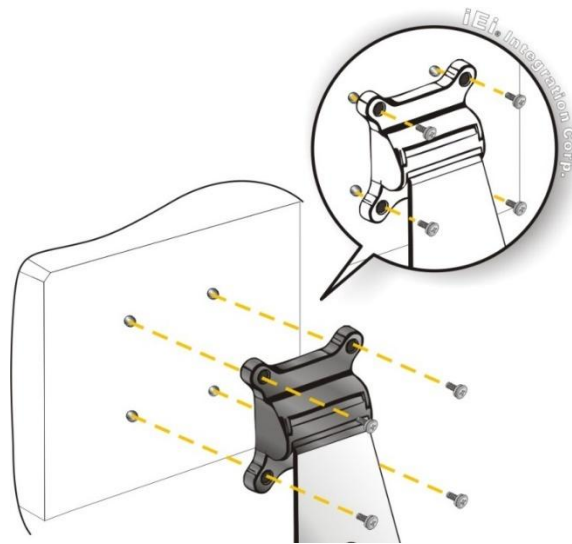

Figure 3-10: Stand Mounting (Stand-Cxx)

3.9 Powering on the System



WARNING:

To reduce potential safety issues, only the power adapter provided with the product, a replacement power adapter provided by IEI, or a power adapter purchased as an accessory from IEI should be used with the product.

To power on the system, follow the steps below:

- Step 1:** Connect the power cord to the power adapter. Connect the other end of the power cord to a power source. Ensure to connect the power cord to a socket-outlet with earthing connection.
- Step 2:** Connect the power adapter to the power connector of the SHIELD-156/185/215. The power LED turns on in amber.
- Step 3:** Locate the power button on the I/O panel.

Step 4: Hold down the power button until the power LED on the front panel turns to green.



Power Button

Figure 3-11: Power Button

3.10 Software Installation

All the drivers for the SHIELD-156/185/215 are available on IEI Resource Download Center (<https://download.ieiworld.com>). Type SHIELD-156/185/215 and press Enter to find all the relevant software, utilities, and documentation.

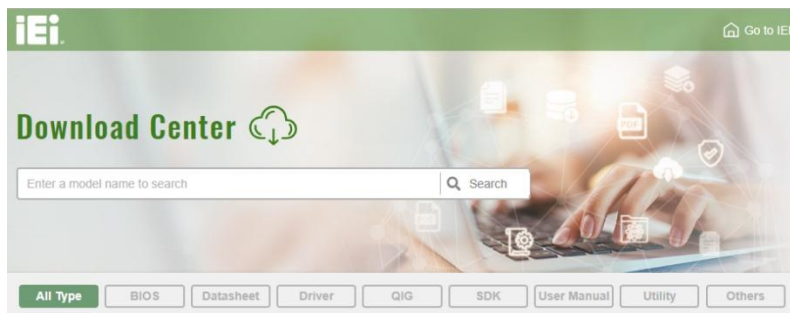

Figure 3-12: IEI Resource Download Center

SHIELD-156/185/215

3.10.1 Driver Download

To download drivers from IEI Resource Download Center, follow the steps below.

Step 1: Go to <https://download.ieiworld.com>. Type SHIELD-156/185/215 and press Enter.

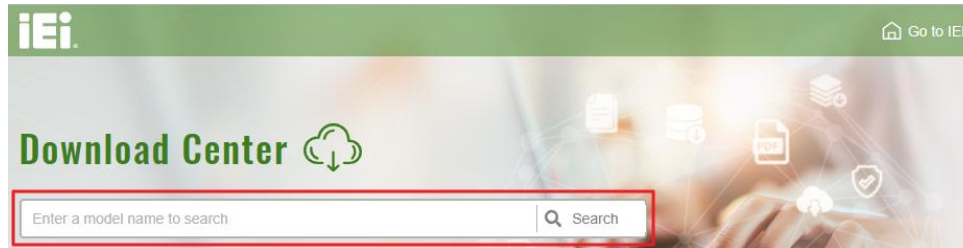

Step 2: All product-related software, utilities, and documentation will be listed. You can choose **Driver** to filter the result.

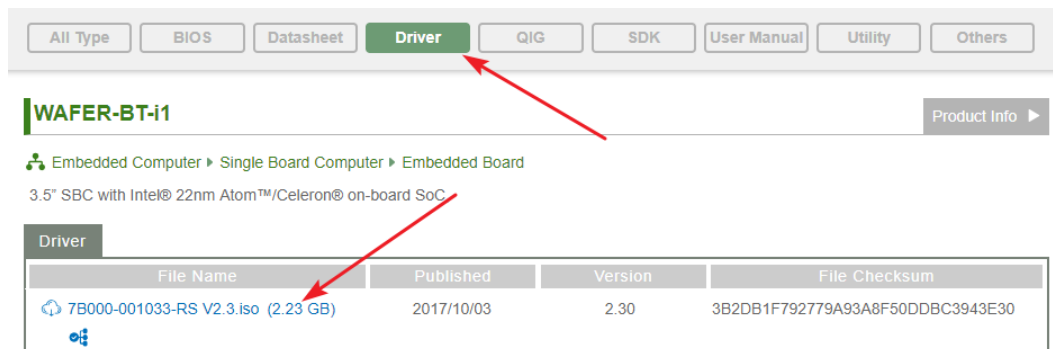

WAFER-BT-i1 Product Info ▶

Embedded Computer ▶ Single Board Computer ▶ Embedded Board

3.5" SBC with Intel® 22nm Atom™/Celeron® on-board SoC

Driver

File Name	Published	Version	File Checksum
7B000-001033-RS V2.3.iso (2.23 GB)	2017/10/03	2.30	3B2DB1F792779A93A8F50DDBC3943E30

Step 3: Click the driver file name on the page and you will be prompted with the following window. You can download the entire ISO file (❶), or click the small arrow to find an individual driver and click the file name to download (❷).

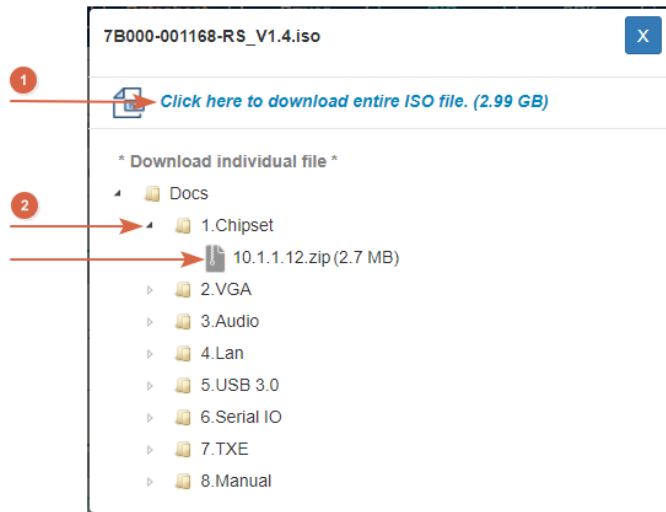

NOTE:

To install software from the downloaded ISO image file in Windows 10, or 11, double-click the ISO file to mount it as a virtual drive to view its content.

Chapter

4

System Maintenance

4.1 System Maintenance Introduction

If the components of the SHIELD-156/185/215 fail they must be replaced. Please contact the system reseller or vendor to purchase the replacement parts. Back cover removal instructions for the SHIELD-156/185/215 are described below.

4.2 Anti-static Precautions



WARNING:

Failure to take ESD precautions during the maintenance of the SHIELD-156/185/215 may result in permanent damage to the SHIELD-156/185/215 and severe injury to the user.

Electrostatic discharge (ESD) can cause serious damage to electronic components, including the SHIELD-156/185/215. Dry climates are especially susceptible to ESD. It is therefore critical that whenever the SHIELD-156/185/215 is accessed internally, or any other electrical component is handled, the following anti-static precautions are strictly adhered to.

- **Wear an anti-static wristband:** - Wearing a simple anti-static wristband can help to prevent ESD from damaging the board.
- **Self-grounding:** - Before handling the board touch any grounded conducting material. During the time the board is handled, frequently touch any conducting materials that are connected to the ground.
- **Use an anti-static pad:** - When configuring the SHIELD-156/185/215, place it on an anti-static pad. This reduces the possibility of ESD damaging the SHIELD-156/185/215.
- **Only handle the edges of the PCB:** - When handling the PCB, hold the PCB by the edges.

4.3 Turn off the Power



WARNING:

Failing to turn off the system before opening it can cause permanent damage to the system and serious or fatal injury to the user.

Before any maintenance procedures are carried out on the system, make sure the system is turned off.

4.4 Reinstalling the Cover



WARNING:

Failing to reinstall the cover may result in permanent damage to the system. Please make sure all coverings are properly installed.

When maintenance procedures are complete, please make sure the back cover is installed.

Chapter

5

Connectors

SHIELD-156/185/215

5.1 Peripheral Interface Connectors

The SHIELD-156/185/215 panel PC motherboard comes with a number of peripheral interface connectors and configuration jumpers. The connector locations are shown in **Figure 5-1** & **Figure 5-2**. The connector pinouts for these connectors are listed in the following sections.

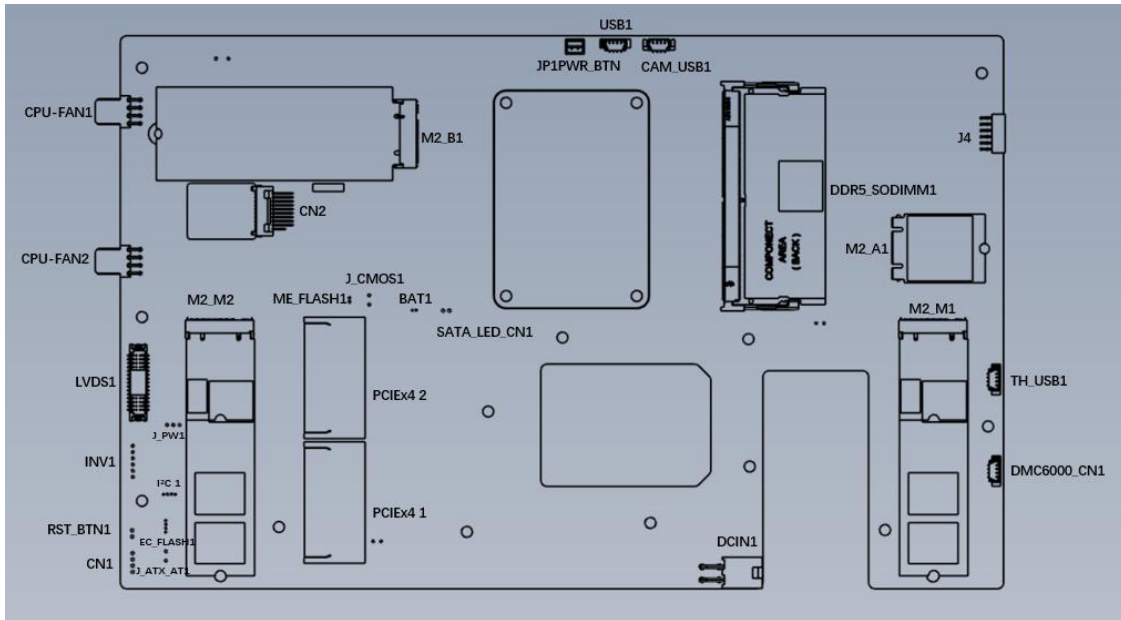

Figure 5-1: Main Board Layout Diagram (Front Side)

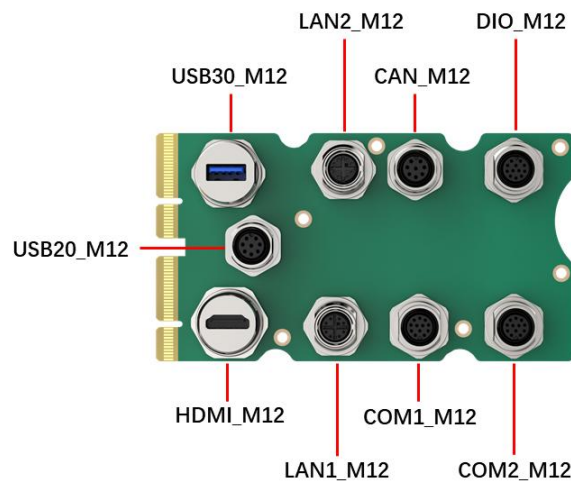

Figure 5-2: I/O Board Layout Diagram

5.2 Internal Peripheral Connectors

Internal peripheral connectors are found on the motherboard and are only accessible when the motherboard is outside of the chassis. The table below shows a list of the peripheral interface connectors on the SHIELD-156/185/215 motherboard. Pinouts of these connectors can be found in the following sections.

Connector	Type	Label
ME Override Connector	2-pin header, p=1.27mm	ME_FLASH1
LVDS Connector	30-pin wafer, p=1.25mm	LVDS1
INV1 Connector	6-pin wafer, p=2.0mm	INV1
LVDS1 Voltage Selection	3-pin header, p=2.0mm	J_PW1
I ² C Connector	4-pin wafer, p=1.25mm	I2C1
USB Hub to Connector	4-pin wafer, p=1.25mm	USB1, TH_USB1, CAM_USB1
Power Button and LED Indicators	2-pin wafer, p=2.0mm	PWR_BTN1
	4-pin wafer, p=2.0mm	CN1
Fan Connector	4-pin wafer, p=2.54mm	CPU_FAN1, CPU_FAN2
Flash SPI ROM Connector	6-pin wafer, p=1.25mm	JBIO1
SPI TPM Card Connector	19-pin header, p=1.27mm	CN2
M.2 E Key Slot	E-key slot	M2_A1
M.2 M Key Slot	M-key slot	M2_M1
M.2 M Key slot	M-key slot	M2_M2
M.2 B Key Slot	B-Key Slot	M2_B1
USB 3.0 to SFP Connector	12-pin header, p=2.0mm	J4
Power Connector	4pin wafer, p=4.2mm	DCIN1

Table 5-1: Peripheral Interface Connectors

5.2.1 ME Override Connector (ME_FLASH1)

PIN NO.	DESCRIPTION
1	1.8V
2	HDA_SDO

Table 5-2: ME Override Connector (ME_FLASH1) Pinouts

5.2.2 LVDS Connector (LVDS1)

PIN NO.	DESCRIPTION	PIN NO.	DESCRIPTION
1	GND	2	GND
3	A0P_L	4	A0M_L
5	A1P_L	6	A1M_L
7	A2P_L	8	A2M_L
9	CLK1P_L	10	CLK1M_L
11	A3P_L	12	A3M_L
13	GND	14	GND
15	A4M_L	16	A4P_L
17	A5M_L	18	A5P_L
19	A6M_L	20	A6P_L
21	CLK2M_L	22	CLK2P_L
23	A7M_L	24	A7P_L
25	GND	26	GND
27	+VCC_LCD_C	28	+VCC_LCD_C
29	+VCC_LCD_C	30	+VCC_LCD_C
31	GND	32	GND

Table 5-3: LVDS Connector (LVDS1) Pinouts

5.2.3 INV1 Connector (INV1)

PIN NO.	DESCRIPTION	PIN NO.	DESCRIPTION
1	VLED	2	VLED
3	VLED	4	BRIGHTNESS
5	GND	6	GND

Table 5-4: INV1 Connector (INV1) Pinouts

5.2.4 LVDS1 Voltage Selection (J_PW1)

PIN NO.	DESCRIPTION
Short 1-2 (default)	+3.3V LVDS

PIN NO.	DESCRIPTION
Short 2-3	+5V LVDS

Table 5-5: LVDS1 Voltage Selection Pinouts

5.2.5 I²C Connector (I2C1)

PIN NO.	DESCRIPTION	PIN NO.	DESCRIPTION
1	GND	2	I2C_DAT_EC
3	I2C_CLK_EC	4	+V5S

Table 5-6: I²C Connector (I2C1) Pinouts

5.2.6 USB Hub to Connector (USB1, TH_USB1, CAM_USB1)

PIN NO.	DESCRIPTION
1	+5V
2	USB4-_GL850_C
3	USB4+_GL850_C
4	GND

Table 5-7: USB Hub to Connector (USB1) Pinouts

PIN NO.	DESCRIPTION
1	+5V
2	USB1-_GL850_C
3	USB1+_GL850_C
4	GND

Table 5-8: USB Hub to Connector (TH_USB1) Pinouts

PIN NO.	DESCRIPTION
1	+5V
2	USB2-_GL850_C
3	USB2+_GL850_C
4	GND

Table 5-9: USB Hub to Connector (CAM_USB1) Pinouts

5.2.7 Power Button and LED Indicators (PWR_BTN1, CN1)

PIN NO.	DESCRIPTION
1	PWRBTN_SW#
2	GND

Table 5-10: Power Button and LED Indicators (PWR_BTN1) Pinouts

PIN NO.	DESCRIPTION
1	PWR_LED+
2	PWR_LED-
3	PWR_BTN+
4	PWR_BTN-

Table 5-11: Power Button and LED Indicators (CN1) Pinouts

5.2.8 Fan Connector (CPU_FAN1, CPU_FAN2)

PIN NO.	DESCRIPTION
1	GND
2	+V12S
3	EC_FANCTL1
4	EC_FANIN1

Table 5-12: Fan Connector (CPU_FAN1, CPU_FAN2) Pinouts

5.2.9 Flash SPI ROM Connector (JBIOS1)

PIN NO.	DESCRIPTION	PIN NO.	DESCRIPTION
1	+3.3V	2	SPI_CS0_N_SW_R1
3	SPI_IO_1_SW_R1	4	SPI_CLK_SW_R1
5	SPI_SI_SW_R1	6	GND

Table 5-13: Flash SPI ROM Connector (JBIOS1) Pinouts

5.2.10 SPI TPM Card Connector (CN2)

PIN NO.	DESCRIPTION	PIN NO.	DESCRIPTION
1	NC	2	PLT_RST_N
3	+V3P3A_TPM	4	SPI_TPM_INT
5	TPM_SERIRQ	6	TPM_WP#
7	GND	8	SPI_CS2_N_TPM
9	SPI_SI_SW_TPM	10	SPI_TPM_HOLD_R_N
11	SPI_IO_1_TPM	12	SPI_IO_3_TPM
13	SPI_IO_2_TPM	14	SPI_CLK_TPM
15	+V3P3A_TPM	16	GND
17	SPI_CS1_N_TPM	18	NC
19	SPI_CS0_N_TPM	20	NC

Table 5-14: SPI TPM Card Connector (CN2) Pinouts

5.2.11 M.2 E Key Slot (M2_A1)

PIN NO.	DESCRIPTION	PIN NO.	DESCRIPTION
1	GND	2	+V3.3_M2
3	USB2_P6_DP_C	4	+V3.3_M2
5	USB2_P6_DN_C	6	NC
7	GND	8	NC
9	NC	10	NC
11	NC	12	NC
13	NC	14	NC
15	NC	16	NC
17	NC	18	GND
19	NC	20	NC
21	NC	22	NC
23	NC	24	GND
25	NC	26	NC
27	NC	28	NC
29	NC	30	GND
31	NC	32	NC

PIN NO.	DESCRIPTION	PIN NO.	DESCRIPTION
33	GND	34	NC
35	PCIE_TXP4_C	36	GND
37	PCIE_TXN4_C	38	NC
39	GND	40	NC
41	PCIE_RXP4_C	42	NC
43	PCIE_RXN4_C	44	NC
45	GND	46	NC
47	PCIE_CLKP0_C	48	NC
49	PCIE_CLKN0_C	50	M2_SUS_CLK
51	GND	52	BUF_PLT_RST_N
53	NC	54	BT_RF_KILL_N
55	PCIE_WAKE#	56	WIFI_RF_KILL_N
57	GND	58	NC
59	NC	60	NC
61	NC	62	NC
63	GND	64	NC
65	NC	66	NC
67	NC	68	NC
69	GND	70	WIGIG_PE_WAKE_N
71	NC	72	+V3.3_M2
73	NC	74	+V3.3_M2
75	GND		

Table 5-15: M.2 E Key Slot (M2_A1) Pinouts

5.2.12 M.2 M Key Slot (M2_M1, M2_M2)

PIN NO.	DESCRIPTION	PIN NO.	DESCRIPTION
1	GND	2	+V3P3S
3	GND	4	+V3P3S
5	NC	6	NC
7	NC	8	NC
9	GND	10	M2_1_LED_N
11	NC	12	+V3P3S

PIN NO.	DESCRIPTION	PIN NO.	DESCRIPTION
13	NC	14	+V3P3S
15	GND	16	+V3P3S
17	NC	18	+V3P3S
19	NC	20	NC
21	GND	22	NC
23	NC	24	NC
25	NC	26	NC
27	GND	28	NC
29	NC	30	NC
31	NC	32	NC
33	GND	34	NC
35	NC	36	NC
37	NC	38	GND
39	GND	40	M2_I2C_CLK
41	PCIE_RXP11_C	42	M2_I2C_DAT
43	PCIE_RXN11_C	44	NC
45	GND	46	NC
47	PCIE_TXN11_C	48	NC
49	PCIE_TXP11_C	50	BUF_PLT_RST_N
51	GND	52	TP309
53	PCIE_CLKN1_C	54	PCIE_WAKE#
55	PCIE_CLKP1_C	56	TP310
57	GND	58	TP311
59	NC	60	NC
61	NC	62	NC
63	NC	64	NC
65	NC	66	NC
67	NC	68	TP312
69	M.2_SATA_PCIE_PEDET	70	+V3P3S
71	GND	72	+V3P3S
73	GND	74	+V3P3S
75	GND		

PIN NO.	DESCRIPTION	PIN NO.	DESCRIPTION
---------	-------------	---------	-------------

Table 5-16: M.2 M Key Slot (M2_M1) Pinouts

PIN NO.	DESCRIPTION	PIN NO.	DESCRIPTION
1	GND	2	+V3P3S
3	GND	4	+V3P3S
5	NC	6	NC
7	NC	8	NC
9	GND	10	M2_1_LED_N
11	NC	12	+V3P3S
13	NC	14	+V3P3S
15	GND	16	+V3P3S
17	NC	18	+V3P3S
19	NC	20	NC
21	GND	22	NC
23	NC	24	NC
25	NC	26	NC
27	GND	28	NC
29	PCIE_RXN10_C	30	NC
31	PCIE_RXP10_C	32	NC
33	GND	34	NC
35	PCIE_TXN10_C	36	NC
37	PCIE_TXP10_C	38	GND
39	GND	40	M2_I2C_CLK
41	PCIE_RXN9_C	42	M2_I2C_DAT
43	PCIE_RXP9_C	44	NC
45	GND	46	NC
47	PCIE_TXN9_C	48	NC
49	PCIE_TXP9_C	50	BUF_PLT_RST_N
51	GND	52	TP313
53	PCIE_CLKN2_C	54	PCIE_WAKE#
55	PCIE_CLKP2_C	56	TP314
57	GND	58	TP315

PIN NO.	DESCRIPTION	PIN NO.	DESCRIPTION
59	NC	60	NC
61	NC	62	NC
63	NC	64	NC
65	NC	66	NC
67	NC	68	TP316
69	M2_IFDET1_N	70	+V3P3S
71	GND	72	+V3P3S
73	GND	74	+V3P3S
75	GND		

Table 5-17: M.2 M Key Slot (M2_M2) Pinouts

5.2.13 M.2 B Key Slot (M2_B1)

PIN NO.	DESCRIPTION	PIN NO.	DESCRIPTION
1	M2_WWAN_CONFIG3	2	+V3P3_M2_BS
3	GND	4	+V3P3_M2_BS
5	GND	6	M2_B1-PIN6
7	USB2_P8_DP_C	8	M2_B1-PIN8
9	USB2_P8_DN_C	10	NC
11	GND	12	NC
13	NC	14	NC
15	NC	16	NC
17	NC	18	NC
19	NC	20	NC
21	NC	22	NC
23	NC	24	NC
25	NC	26	GNSS_DISABLE_N
27	GND	28	NC
29	USB3_RX2_N_C	30	M2_WWAN_UIM1_RST_N
31	USB3_RX2_P_C	32	M2_WWAN_UIM1_CLK
33	GND	34	M2_WWAN_UIM1_DATA
35	USB3_TX2_N_C	36	+V_UIM1_PWR
37	USB3_TX2_P_C	38	NC

PIN NO.	DESCRIPTION	PIN NO.	DESCRIPTION
39	GND	40	NC
41	PCIE_RXN3_C	42	NC
43	PCIE_RXP3_C	44	NC
45	GND	46	NC
47	PCIE_TXN3_C	48	NC
49	PCIE_TXP3_C	50	M.2_RST_N
51	GND	52	NC
53	PCIE_CLKN3_C	54	PE_WAKE_N
55	PCIE_CLKP3_C	56	NC
57	GND	58	NC
59	NC	60	WWAN_COEX3
61	NC	62	WWAN_COEX2
63	NC	64	WWAN_COEX1
65	NC	66	M2_WWAN_SIM1_DET
67	NC	68	TP320
69	GND	70	+V3P3_M2_BS
71	GND	72	+V3P3_M2_BS
73	GND	74	+V3P3_M2_BS
75	GND		

Table 5-18: M.2 B Key Slot (M2_B1) Pinouts

5.2.14 USB 3.0 to SFP Connector (J4)

PIN NO.	DESCRIPTION	PIN NO.	DESCRIPTION
1	+V5A	2	USB3_TX4_P_C
3	+V5A	4	USB3_TX4_N_C
5	GND	6	GND
7	USB2_P3_DP_C	8	USB3_RX4_P_C
9	USB2_P3_DN_C	10	USB3_RX4_N_C
11	SFP1_MODDET#	12	GND

Table 5-19: USB 3.0 to SFP Connector (J4) Pinouts

5.2.15 Power Connector (DCIN1)

PIN NO.	DESCRIPTION
1	GND_VIN
2	GND_VIN
3	DC_IN
4	DC_IN

Table 5-20: Power Connector (DCIN1) Pinouts

5.3 Jumper Setting

Jumper	LABEL
Clear CMOS Button	J_CMOS1
Auto Power Button Setting	J_ATX_AT1
RESET BTN	RST_BTN1
LVDS Panel Resolution Selection	SW1

Table 5-21: Jumper Setting

5.3.1 Clear CMOS Button (J_CMOS1)

BAT1 To reset the BIOS, remove the on-board battery and press the clear J_CMOS1 button for three seconds or more. The clear J_CMOS1 button location is shown below.



5.3.2 Auto Power Button Setting (J_ATX_AT1)

J_ATX_AT1 is used to configure Auto Power Button enable or disable.

J_ATX_AT1	DESCRIPTION	
A-B	ATX mode (Default)	
B-C	AT mode	

Table 5-22: Auto Power Button Setting (J_ATX_AT1)

SHIELD-156/185/215

5.3.3 RESET BTN (RST_BTN1)

PIN NO.	DESCRIPTION
1	PM_SYSRST_R#
2	GND

Table 5-23: Backlight Enable Selection (J_BL_EN)

5.4 LVDS Panel Resolution Selection (SW1)

* ON=0, OFF=1; Single=S, Dual=D

SW1	Description
(4-3-2-1)	
0000	800x600 18bit S (Default)
0001	1024x768 18bit S
0010	1024x768 24bit S
0011	1280x768 18bit S
0100	1280x800 18bit S
0101	1280x960 18bit S
0110	1280x1024 24bit D
0111	1366x768 18bit S
1000	1366x768 24bit S
1001	1440x960 24bit D
1010	1400x1050 24bit D
1011	1600x900 24bit D
1100	1680x1050 24bit D
1101	1600x1200 24bit D
1110	1920x1080 24bit D
1111	1920x1200 24bit D

Table 5-24: LVDS Resolution Selection (SW1) Settings

5.5 External Interface Panel Connectors

The table below lists the rear panel connectors on the SHIELD-156/185/215 motherboard. Pinouts of these connectors can be found in the following sections.

Connector	Type	Label
COM1	RS232 M12 Connector	COM1_M12
COM2	RS232/422/485 M12 Connector	COM2_M12
LAN1	LAN M12 Connector	LAN1_M12
LAN2	LAN M12 Connector	LAN2_M12
DIO	DIO M12 Connector	DIO_M12
CAN	CAN M12 Connector	CAN_M12
USB2.0	USB2.0 M12 Connector	USB20_M12
USB3.0	USB3.0 M20 Connector	USB30_M12
HDMI	HDMI M20 Connector	HDMI_M12

Table 5-25: External Interface Panel Connectors

5.5.1 COM1 RS-232 M12 Connector (COM1_M12)

PIN NO.	DESCRIPTION	PIN NO.	DESCRIPTION
1	T-NDCD2	7	T-NRTS2
2	T-NSIN2	8	T-NCTS2
3	T-NSOUT2	9	T-XRI2
4	T-NDTR2	10	NC
5	GND	11	NC
6	T-NDSR2	12	NC

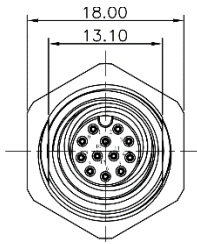

Table 5-26: COM1 RS-232 M12 Connector (COM1_M12) Pinouts

5.5.2 COM2 RS-232/422/485 M12 Connector (COM2_M12)

PIN NO.	DESCRIPTION	PIN NO.	DESCRIPTION
1	T-NDCD2	7	T-NRTS2
2	T-NSIN2	8	T-NCTS2
3	T-NSOUT2	9	T-XRI2
4	T-NDTR2	10	NC
5	GND	11	NC
6	T-NDSR2	12	NC

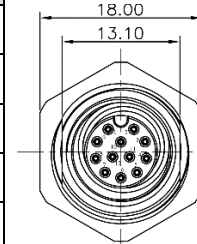

Table 5-27: COM2 RS-232/422/485 M12 Connector (COM2_M12) Pinouts

5.5.3 LAN1 M12 Connector (LAN1_M12)

PIN NO.	DESCRIPTION	PIN NO.	DESCRIPTION
1	TRD1P0_M12_R	5	TRD1P3_M12_R
2	TRD1N0_M12_R	6	TRD1N3_M12_R
3	TRD1P1_M12_R	7	TRD1N2_M12_R
4	TRD1N1_M12_R	8	TRD1P2_M12_R

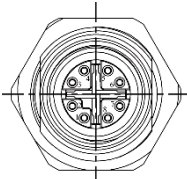

Table 5-28: LAN1 M12 Connector (LAN1_M12) Pinouts

5.5.4 LAN2 M12 Connector (LAN2_M12)

PIN NO.	DESCRIPTION	PIN NO.	DESCRIPTION
1	TRD2P0_M12_R	5	TRD2P3_M12_R
2	TRD2N0_M12_R	6	TRD2N3_M12_R
3	TRD2P1_M12_R	7	TRD2N2_M12_R
4	TRD2N1_M12_R	8	TRD2P2_M12_R

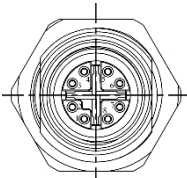

Table 5-29: LAN2 M12 Connector (LAN2_M12) Pinouts

5.5.5 DIO M12 Connector (DIO_M12)

PIN NO.	DESCRIPTION	PIN NO.	DESCRIPTION
1	GPO1_DIO_M12	7	GPO4_DIO_M12
2	GPI1_DIO_M12	8	GPI4_DIO_M12
3	GPO2_DIO_M12	9	SMB1_CLK_M12_C
4	GPI2_DIO_M12	10	SMB1_DATA_M12_C
5	GPO3_DIO_M12	11	5V_DIO
6	GPI3_DIO_M12	12	GND_DIO

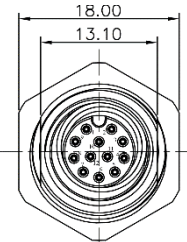

Table 5-30: DIO M12 Connector (DIO_M12) Pinouts

5.5.6 CAN M12 Connector (CAN_M12)

PIN NO.	DESCRIPTION	PIN NO.	DESCRIPTION
1	CAN2L	5	CAN2_G
2	CAN1H	6	CAN1_G
3	CAN1L	7	CAN2H
4	NC	8	NC

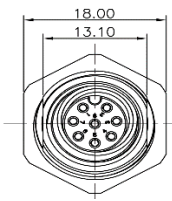

Table 5-31: CAN M12 Connector (CAN_M12) Pinouts

5.5.7 USB2.0 M12 Connector (USB20_M12)

PIN NO.	DESCRIPTION	PIN NO.	DESCRIPTION
1	VCC_USB45	5	VCC_USB45
2	USB_PN4-_M12_C	6	USB_PN5-_M12_C
3	USB_PP4+_M12_C	7	USB_PP5+_M12_C
4	GND	8	GND

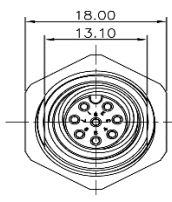

Table 5-32: USB2.0 M12 Connector (USB20_M12) Pinouts

5.5.8 USB3.0 M20 Connector (USB30_M12)

PIN NO.	DESCRIPTION	PIN NO.	DESCRIPTION
1	VCC_USB3_M12	5	USB3_RX1_N_M12_C
2	USB_PN1-_M12_C	6	USB3_RX1_P_M12_C
3	USB_PP1+_M12_C	7	GND
4	GND	8	USB3_TX1_N_M12_C
9	USB3_TX1_P_M12_C		

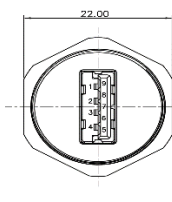

Table 5-33: USB3.0 M20 Connector (USB30_M12) Pinouts

5.5.9 HDMI M20 Connector (HDMI_M12)

PIN NO.	DESCRIPTION	PIN NO.	DESCRIPTION
1	HDMI1_DATA2_M12_C	2	GND
3	HDMI1_DATA2#_M12_C	4	HDMI1_DATA2#_M12_C
5	GND	6	HDMI1_DATA1#_M12_C
7	HDMI1_DATA0_M12_C	8	GND
9	HDMI1_DATA0#_M12_C	10	HDMI1_CLK_M12_C
11	GND	12	HDMI1_CLK#_M12_C
13	HDMI_CEC_M12	14	NC
15	HDMI_SCL-1_M12	16	HDMI_SDA-1_M12
17	GND	18	+V5S_HDMI1_M12
19	HDMI1_HPD_M12		

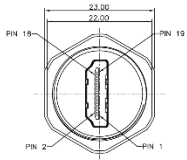

Table 5-34: HDMI M20 Connector (HDMI_M12) Pinouts

Chapter

6

BIOS

6.1 Introduction

The BIOS is programmed onto the BIOS chip. The BIOS setup program allows changes to certain system settings. This chapter outlines the options that can be changed.



NOTE:

Some of the BIOS options may vary throughout the life cycle of the product and are subject to change without prior notice.

6.1.1 Starting Setup

The UEFI BIOS is activated when the computer is turned on. The setup program can be activated in one of two ways.

1. **Using keyboard:** Press the **DEL** or **F2** as soon as the system is turned on.
2. **Using touchscreen:** Press the **Setup** button on the upper right corner of the BIOS Starting Menu.

If the message disappears before the **DEL** or **F2** key is pressed, restart the computer and try again, then the BIOS Starting Menu will appear. Select "Setup" and press Enter to get into the BIOS Setup.

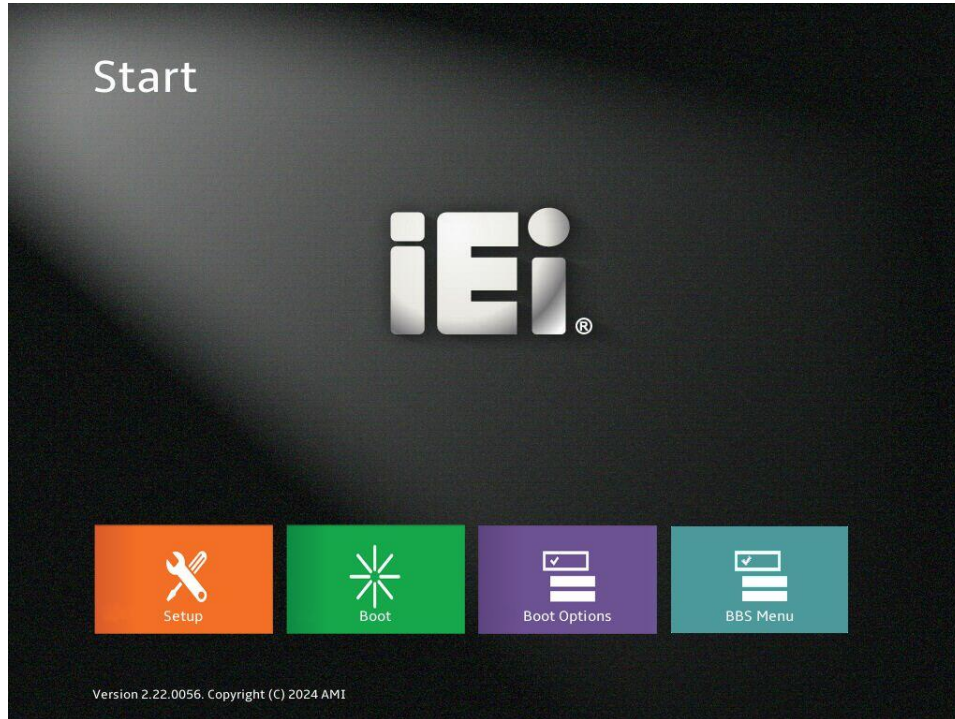

Figure 6-1: BIOS Starting Menu

6.1.2 Using Setup

The BIOS Setup menu can be navigated by using a keyboard or a touchscreen.

6.1.3 Keyboard Navigation

For keyboard navigation, use the navigation keys shown in **Table 6-1**.

Key	Function
Up arrow	Move to previous item
Down arrow	Move to next item
Left arrow	Move to the item on the left hand side
Right arrow	Move to the item on the right hand side
+	Increase the numeric value or make changes
-	Decrease the numeric value or make changes
Page Up	Move to the previous page
Page On	Move to the next page

SHIELD-156/185/215

Esc	Main Menu – Quit and not save changes into CMOS Status Page Setup Menu and Option Page Setup Menu -- Exit current page and return to Main Menu
F1	General help, only for Status Page Setup Menu and Option Page Setup Menu
F2	Load previous values
F3	Load optimized defaults
F4	Save changes and Exit BIOS
<K>	Scroll help area upwards
<M>	Scroll help area downwards

Table 6-1: BIOS Navigation Keys

6.1.3.1 Touch Navigation

For touchscreen navigation, use the on-screen navigation keys shown below.

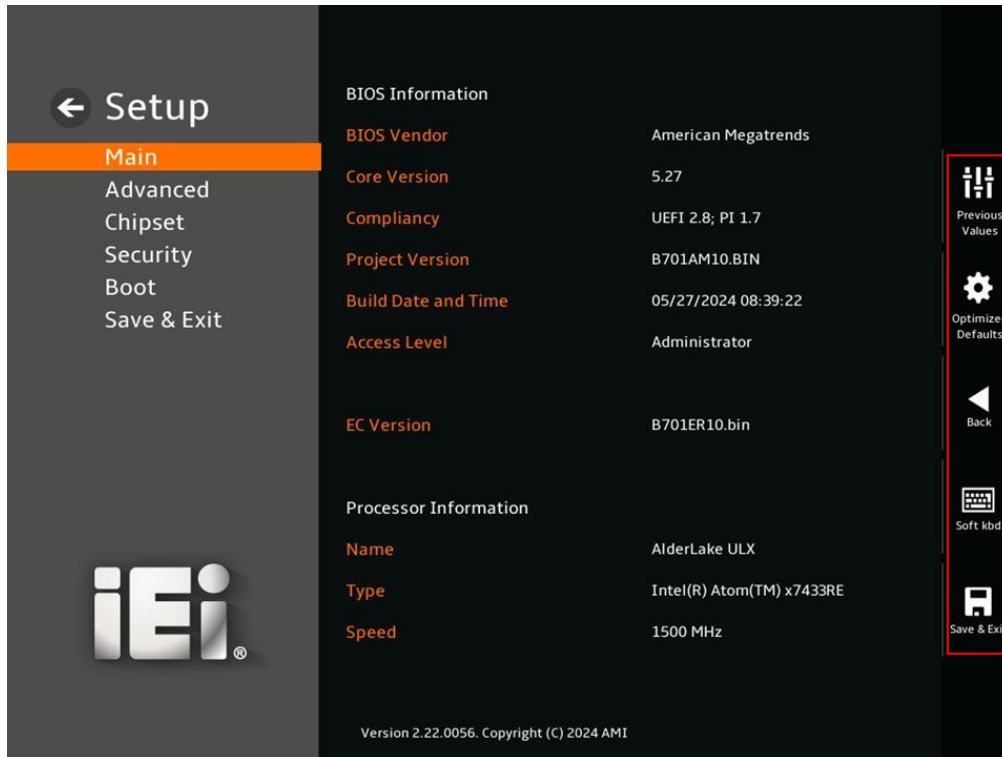

Figure 6-2: On-screen Navigation Keys

On-screen Button	Function
Previous Values	Load the last value you set.
Optimized Defaults	Load the factory default values in order to achieve the best performance.
Back	Return to the previous menu.
Soft kbd	Display the on-screen keyboard.
Save & Exit	Save the changes made to the BIOS options and reset the system.

Table 6-2: BIOS On-screen Navigation Keys

SHIELD-156/185/215

6.1.4 Getting Help

When **F1** is pressed a small help window describing the appropriate keys to use and the possible selections for the highlighted item appears. To exit the Help Window, press the **Esc** key.

6.1.5 Unable to Reboot after Configuration Changes

If the computer cannot boot after changes to the system configuration is made, CMOS defaults. Use the clear CMOS button described in **3.6**.

6.1.6 BIOS Menu Bar

The **menu bar** on top of the BIOS screen has the following main items:

- Main – Changes the basic system configuration.
- Advanced – Changes the advanced system settings.
- Chipset – Changes the chipset settings.
- Security – Sets User and Supervisor Passwords.
- Boot – Changes the system boot configuration.
- Save & Exit – Selects exit options and loads default settings

The following sections completely describe the configuration options found in the menu items at the left of the BIOS screen and listed above.

6.2 Main

The **Main** BIOS menu appears when the **BIOS Setup** program is entered. The **Main** menu gives an overview of the basic system information.



Figure 6-3: BIOS Main (1/3)

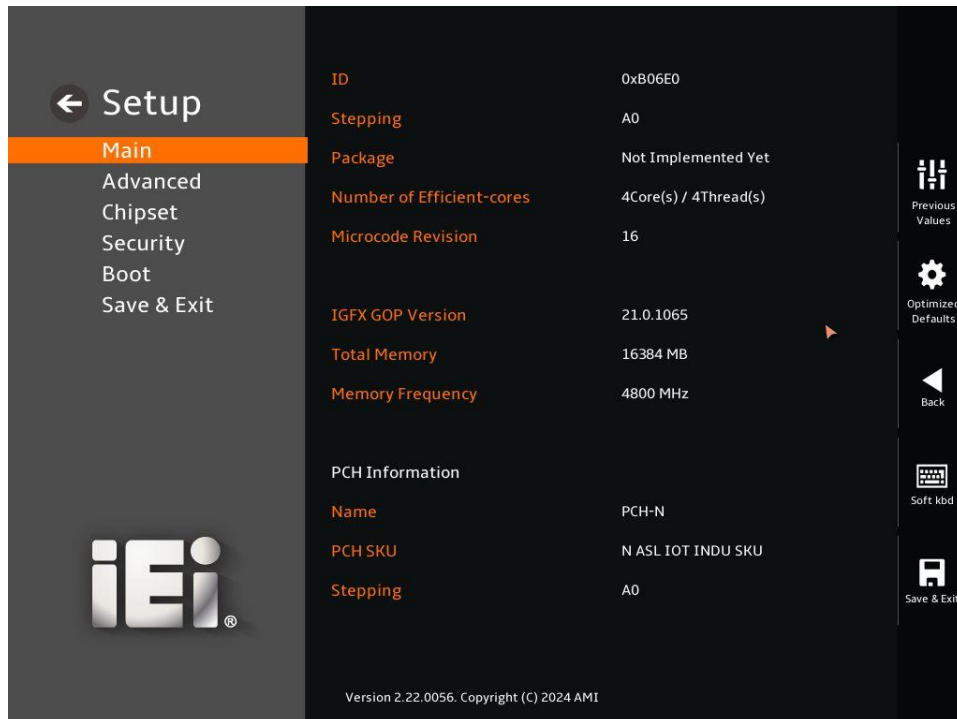

Figure 6-4: BIOS Main (2/3)

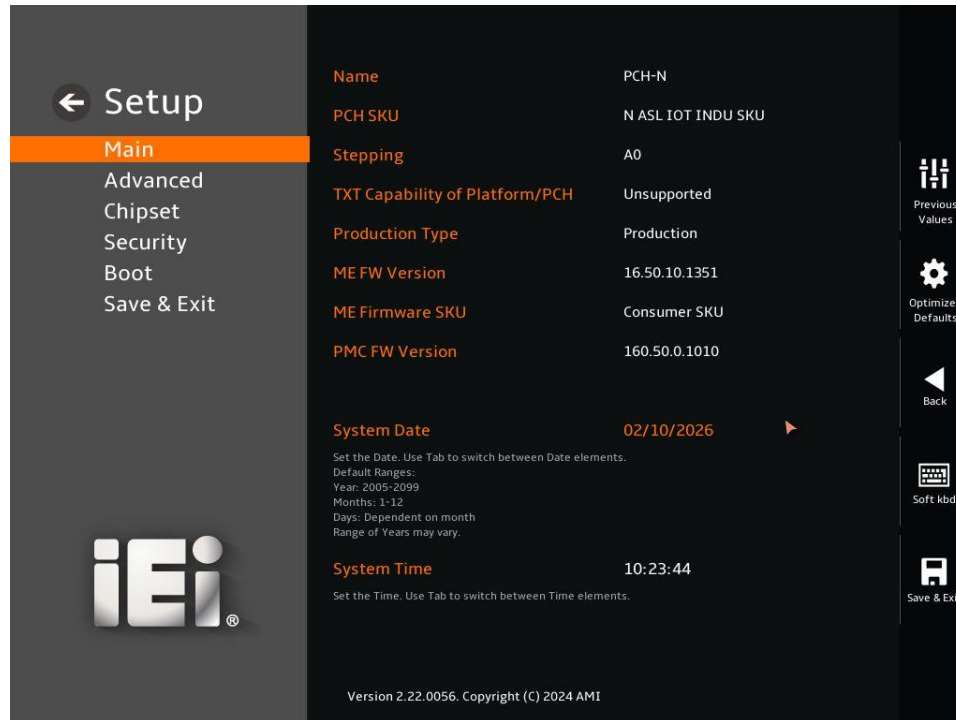

Figure 6-5: BIOS Main (3/3)

→ BIOS Information

The **BIOS Information** lists a brief summary of the BIOS. The fields in **BIOS Information** cannot be changed. The items shown in the system overview include:

- **BIOS Vendor:** Installed BIOS vendor
- **Core Version:** Current BIOS version
- **Compliance:** Current UEFI & PI version
- **Project Version:** the board version
- **Build Date and Time:** Date the current BIOS version was made
- **Access Level:** Administrator
- **EC Version:** Current EC version

→ Processor Information

The **Processor Information** lists a brief summary of the Processor. The fields in **Processor Information** cannot be changed. The items shown in the system overview include:

- **Name:** Displays the Processor Details
- **Type:** Displays the Processor Type
- **Speed:** Displays the Processor Speed
- **ID:** Displays the Processor ID
- **Stepping:** Displays the Processor Stepping
- **Package:** Processor packaging information
- **Number of Efficient-core(s):** Specifies the number of efficiency cores and threads **of the processor**
- **Microcode Revision:** CPU Microcode Revision
- **IGFX GOP Version:** Integrated Graphics card Graphics Output Protocol Version
- **Total Memory:** Total Memory in the System
- **Memory Frequency:** Displays the Frequency of Memory

→ PCH Information

The **PCH Information** lists a brief summary of the PCH. The fields in **PCH Information** cannot be changed. The items shown in the system overview include:

- **Name:** Displays the PCH Name
- **PCH SKU:** Displays the PCH SKU
- **Stepping:** Displays the PCH Stepping
- **TXT Capability of Platform/PCH:** Does the platform support Intel technology
- **Production Type:** Manufacturing Type
- **ME FW Version:** Displays the ME Firmware Version
- **ME Firmware SKU:** Displays the ME Firmware SKU
- **PMC FW Version:** Power management controller firmware version
- **System Date [xx/xx/xx]:** Use the System Date option to set the system date.
Manually enter the day, month and year.
- **System Time [xx: xx: xx]:** Use the System Time option to set the system time.
Manually enter the hours, minutes and seconds.

6.3 Advanced

Use the **Advanced** menu to configure the CPU and peripheral devices through the following sub-menus:

SHIELD-156/185/215



WARNING!

Setting the wrong values in the sections below may cause the system to malfunction. Make sure that the settings made are compatible with the hardware.

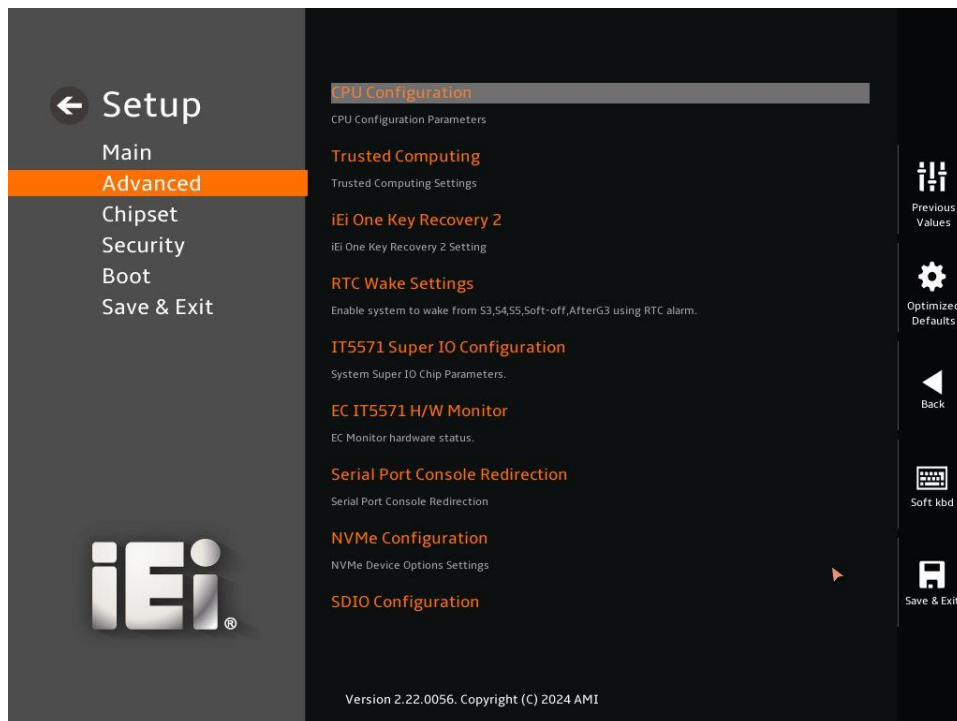

Figure 6-6: BIOS Advanced

6.3.1 CPU Configuration

Use the **CPU Configuration** menu to view detailed CPU specifications or enable the Intel Virtualization Technology.

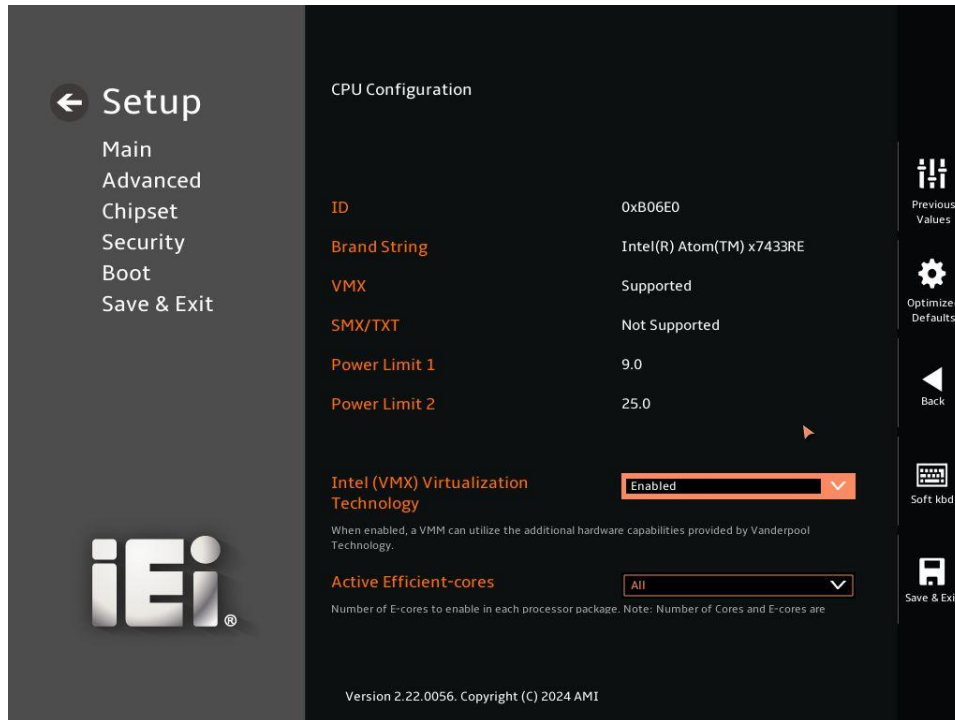

Figure 6-7: CPU Configuration (1/2)

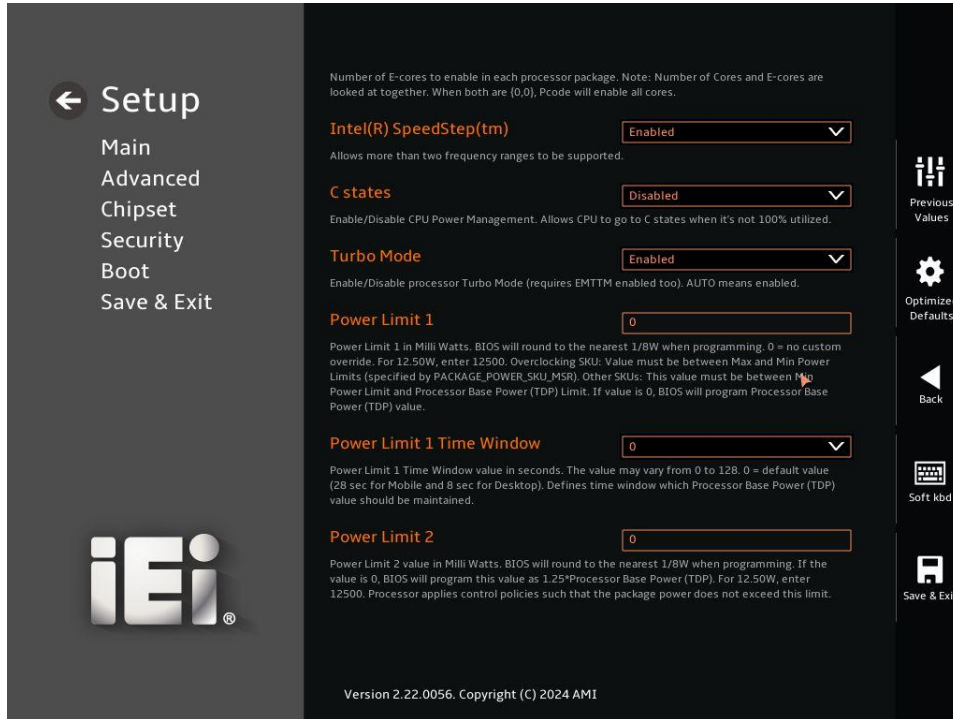

Figure 6-8: CPU Configuration (2/2)

➔ **Intel (VMX) Virtualization Technology [Enabled]**

Use the **Intel (VMX) Virtualization Technology** option to enable or disable virtualization on the system. When combined with third party software, Intel® Virtualization technology allows several OSs to run on the same system at the same time. When enabled, a VMM can utilize the additional hardware capabilities provided by Vanderpool Technology

- ➔ **Disabled** Disables Intel Virtualization Technology.
- ➔ **Enabled** **DEFAULT** Enables Intel Virtualization Technology.

➔ **Active Efficient-cores [All]**

Use the **Active Efficient-cores** BIOS option to enable numbers of Efficient-cores in the processor package. Number of E-cores to enable in each processor package. Note: Number of Cores and E-Cores are looked at together. When both are {0,0}, Pcode will enable all cores.

- ➔ **All** **DEFAULT** Enable all cores in the processor package.
- ➔ **0** Enable no core in the processor package.

- 1 Enable one core in the processor package.
- 2 Enable two cores in the processor package.
- 3 Enable three cores in the processor package.
- 4 Enable four cores in the processor package.
- 5 Enable five cores in the processor package.
- 6 Enable six cores in the processor package.
- 7 Enable seven cores in the processor package.

→ **Intel® SpeedStep™ [Enable]**

Allows more than two frequency ranges to be supported.

- **Disabled** Disables Intel® SpeedStep™
- **Enabled** **DEFAULT** Enables Intel® SpeedStep™

→ **C states [Disabled]**

Use the **C states** option to enable or disable the CPU Power Management.

- **Disabled** **DEFAULT** Disables CPU to go to C states when it's not 100% utilized.
- **Enabled** Enables CPU to go to C states when it's not 100% utilized.

→ **Turbo Mode**

Use the **Turbo Mode** option to enable or disable processor Turbo Mode.

- **Enabled** **DEFAULT** Enable the processor to enter Turbo Mode.
- **Disabled** Disabled the processor to enter Turbo Mode.

→ **Power Limit 1**

Use the **Power Limit 1** to set Power Limit in Milli Watts. BIOS will round to the nearest 1/8W when programming. 0 = no custom override. For 12.50W, enter 12500. Overclocking SKU: Value must be between Max and Min Power Limits. Other SKUs: This value must be between Min Power limit and TDP Limit. If value is 0, BIOS will program TDP value.

SHIELD-156/185/215

→ Power Limit 1 Time Window

Power Limit 1 Time Window value in second. The value may vary from 0 to 128.0, 0 = default value (28 sec for mobile and 8 sec for desktop). Defines time window which TDP value should be maintained.

→ Power Limit 2

Use the **Power Limit 2** to set Power Limit in Milli Watts. BIOS will round to the nearest 1/8W when programming. If the value is 0, BIOS will program this value as 1.25*TDP. For 12.50W, enter 12500. Processor applies control policies such that the package power does not exceed this limit.

6.3.2 Trusted Computing

Use the **Trusted Computing** menu to configure settings related to the Trusted Computing Group (TCG) Trusted Platform Module (TPM).

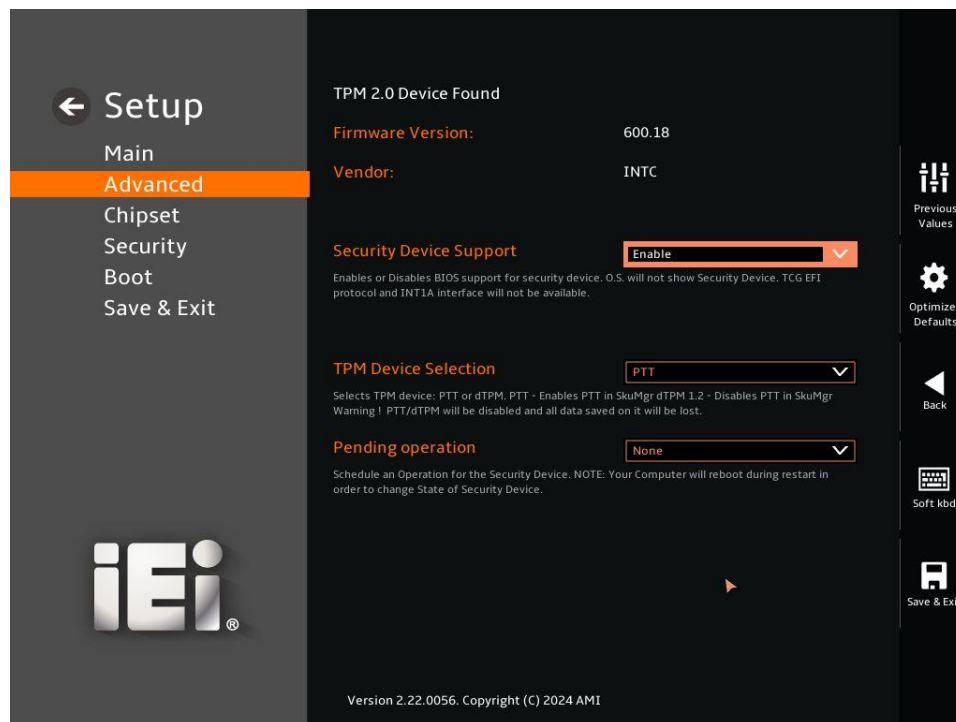

Figure 6-9: Trusted Computing

6.3.3 iEi One Key Recovery 2

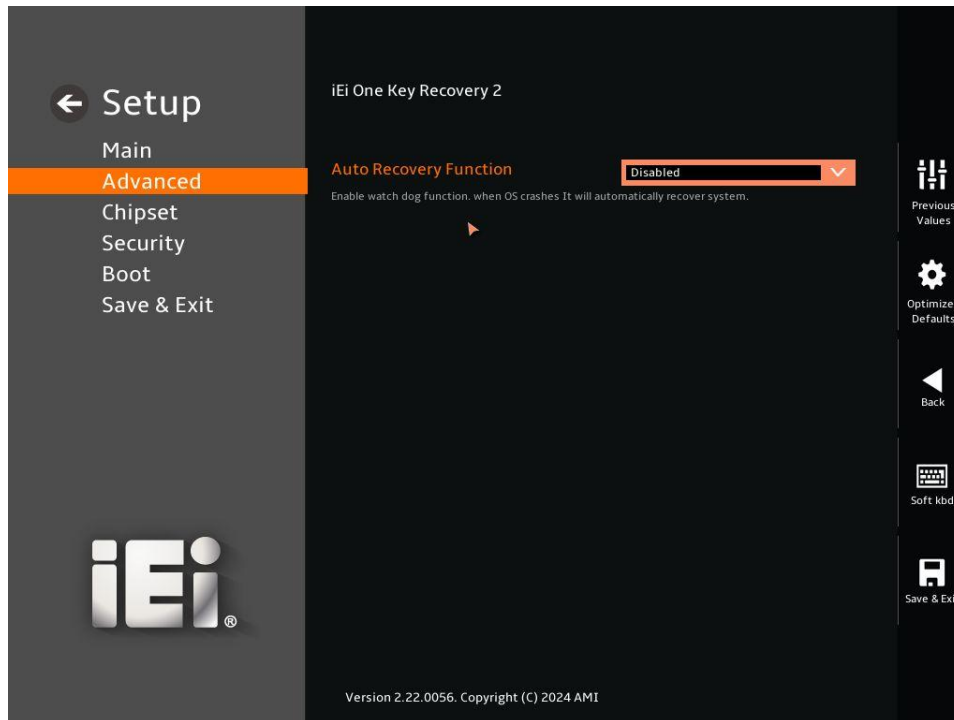

Figure 6-10: iEi One Key Recovery 2

→ Auto Recovery Function [Disabled]

Use the **Auto Recovery Function** option to configure watch dog function.

- **Disabled** **DEFAULT** Auto recovery support is disabled.
- **Enabled** Auto recovery support is enabled.

6.3.4 RTC Wake Settings

The **RTC Wake Settings** menu configures RTC wake event.

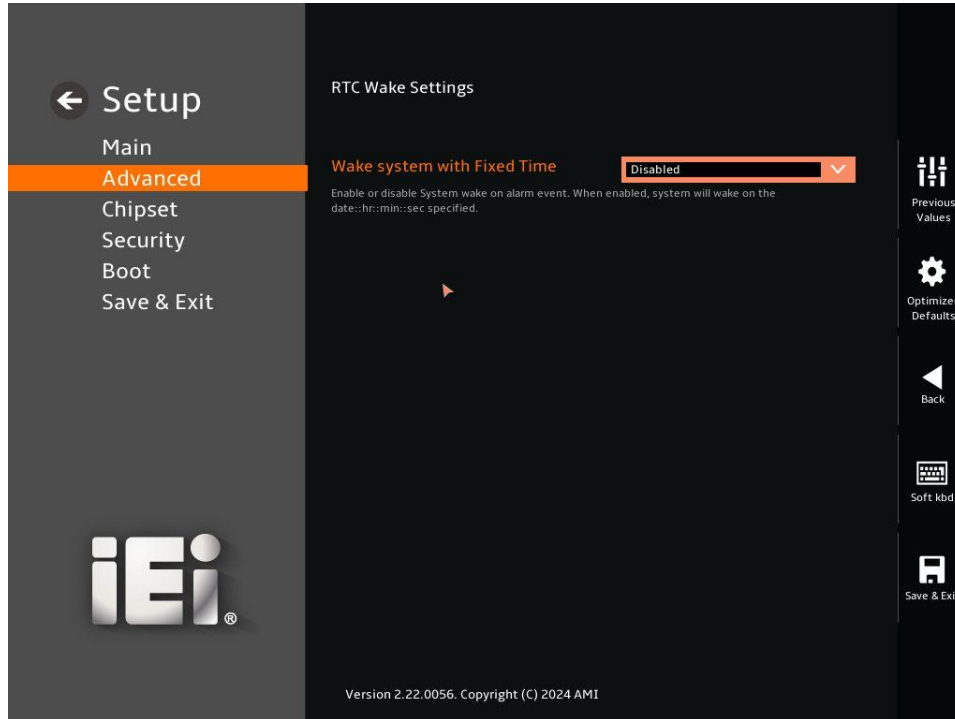

Figure 6-11: RTC Wake Settings

➔ **Wake System with Fixed Time [Disabled]**

Use the **Wake System with Fixed Time** option to specify the time the system should be roused from a suspended state.

- ➔ **Disabled** **DEFAULT** The real time clock (RTC) cannot generate a wake event
- ➔ **Enabled** If selected, the following appears with values that can be selected:

6.3.5 IT5571 Super IO Configuration

Use the **IT5571 Super IO Configuration** menu to set or change the configurations for serial ports.

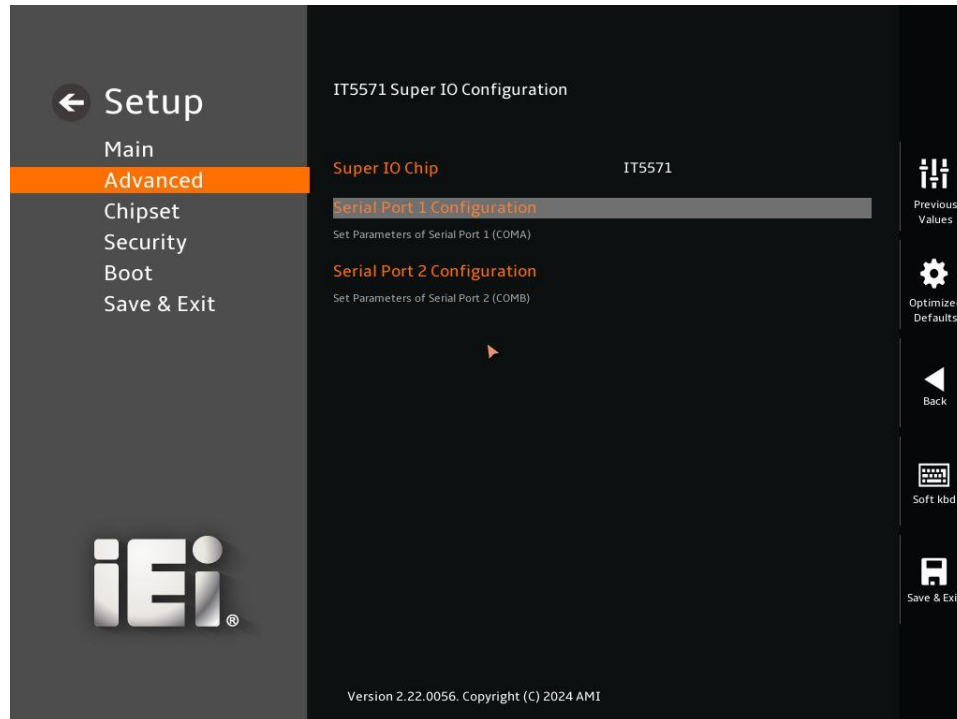

Figure 6-12: IT5571 Super IO Configuration

6.3.5.1 Serial Port 1 Configuration

Use the **Serial Port 1 Configuration** menu to configure the serial port.

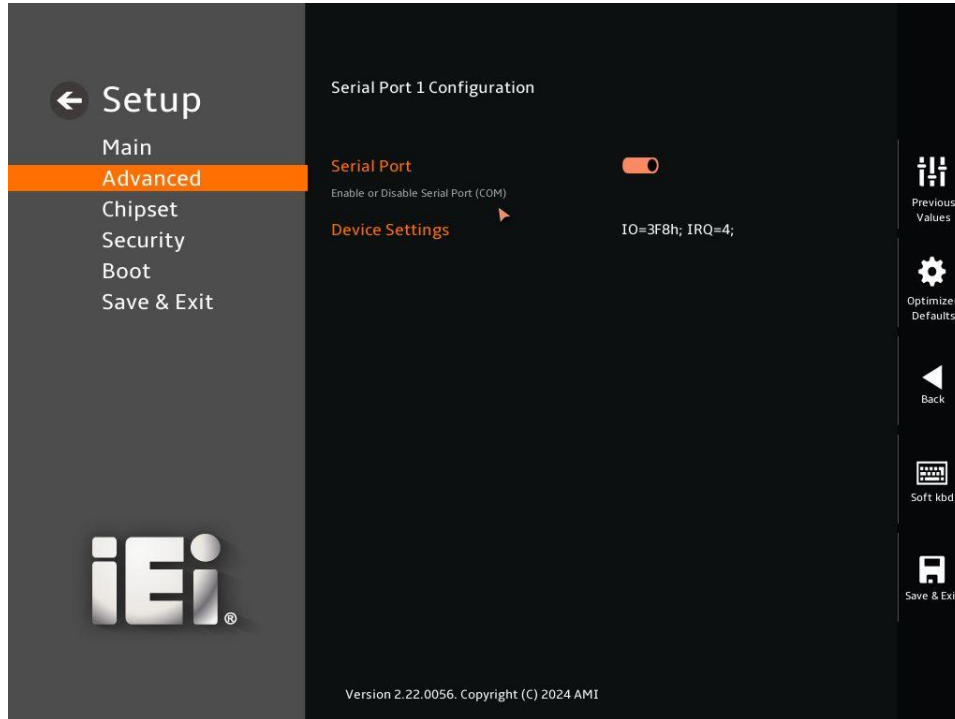

Figure 6-13: Serial Port 1 Configuration

➔ **Serial Port [Enabled]**

Use the **Serial Port** option to enable or disable the serial port.

- ➔ **Disabled** Disable the serial port
- ➔ **Enabled** **DEFAULT** Enable the serial port

➔ **Device Settings**

The **Device Settings** option shows the serial port IO port address and interrupt address.

- ➔ **IO=3F8h;** Serial Port I/O port address is 3F8h and the interrupt
IRQ=4 address is IRQ4

6.3.5.2 Serial Port 2 Configuration

Use the **Serial Port 2 Configuration** menu to configure the serial port.

SHIELD-156/185/215

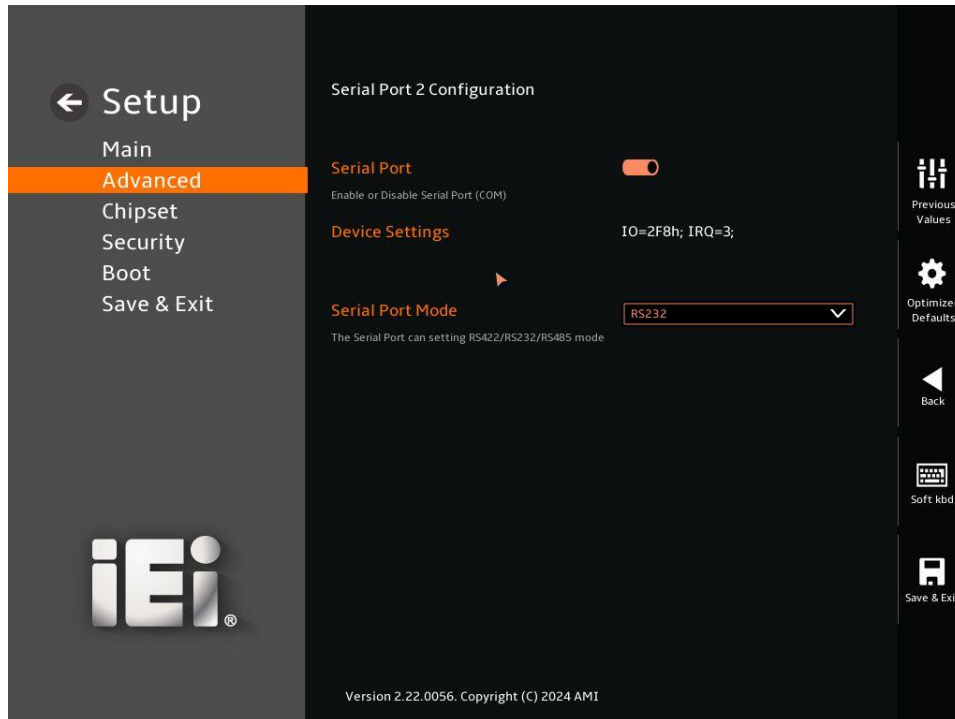

Figure 6-14: Serial Port 2 Configuration

→ Serial Port [Enabled]

Use the **Serial Port** option to enable or disable the serial port.

- **Disabled** Disable the serial port
- **Enabled** **DEFAULT** Enable the serial port

→ Device Settings

The **Device Settings** option shows the serial port IO port address and interrupt address.

- **IO=2F8h;** Serial Port I/O port address is 2F8h and the interrupt
IRQ=3 address is IRQ3

→ Device Port Mode [RS232]

Use the **Device Port Mode** option to select the Serial Port 2 signaling mode. Configuration options are listed below.

- ➔ **RS232** **DEFAULT** Serial Port 5 signaling mode is RS-232.
- ➔ **RS422** Serial Port 5 signaling mode is RS-422.
- ➔ **RS485** Serial Port 5 signaling mode is RS-485.

6.3.6 EC IT5571 H/W Monitor

The **EC IT5571 H/W Monitor** menu shows the state of H/W real-time operating temperature, fan speed and system voltages, and contains the system thermal control and the smart fan mode configuration submenus.

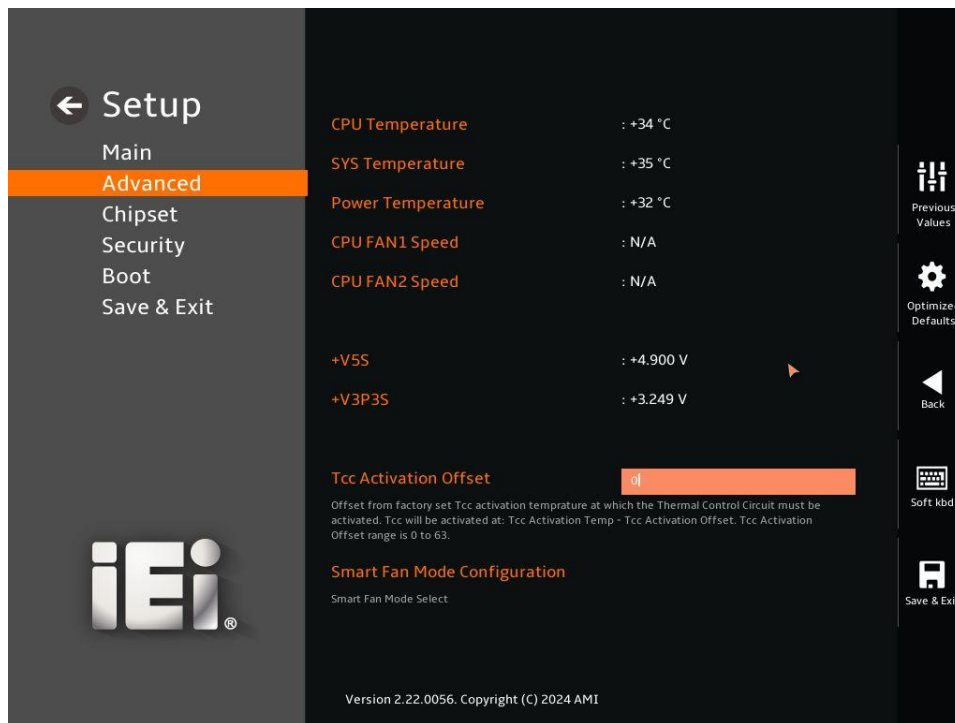

Figure 6-15: EC IT5571 H/W Monitor

➔ **PC Health Status**

The following system parameters and values are shown. The system parameters that are monitored are:

- CPU Temperature
- SYS Temperature
- SYS Temperature2

SHIELD-156/185/215

- Power Temperature
- CPU Fan1 Speed
- CPU Fan2 Speed
- +5V
- +3.3V

→ Tcc Activation Offset [0]

This setting adjusts the offset from the factory-defined Thermal Control Circuit (TCC) activation temperature, determining when the TCC should activate. The activation temperature is calculated as: $TCC \text{ Activation Temperature} = \text{Factory Set Temperature} - TCC \text{ Activation Offset}$. The offset range is between 0 and 63.

6.3.6.1 Smart Fan Mode Configuration

Use the **Smart Fan Mode Configuration** submenu to configure the CPU/system fan start/off temperature and control mode.

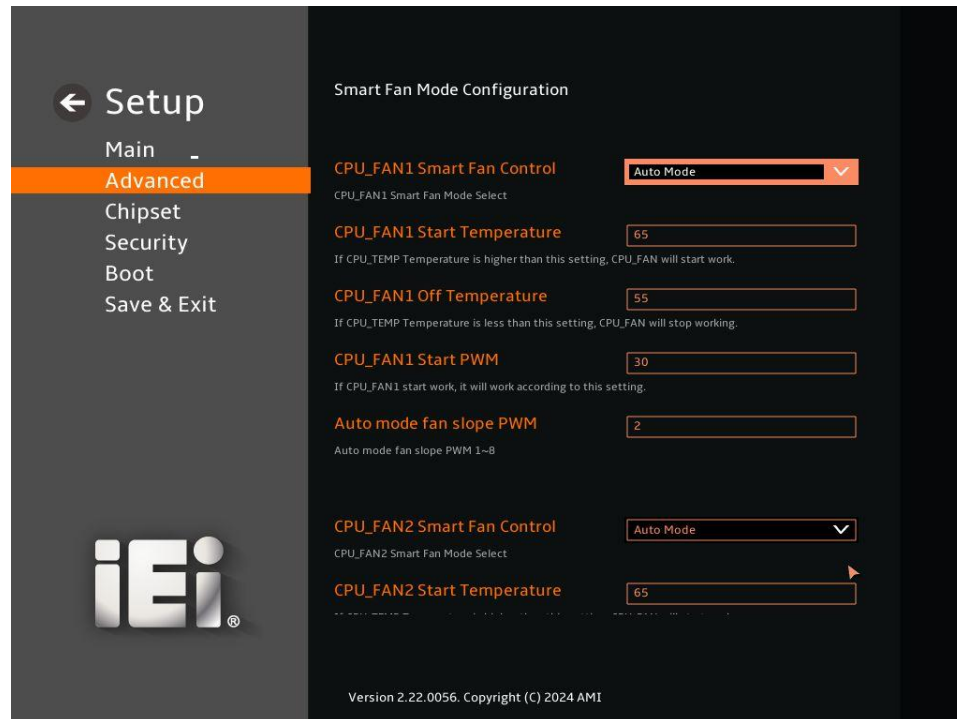

Figure 6-16: Smart Fan Mode Configuration (1/2)

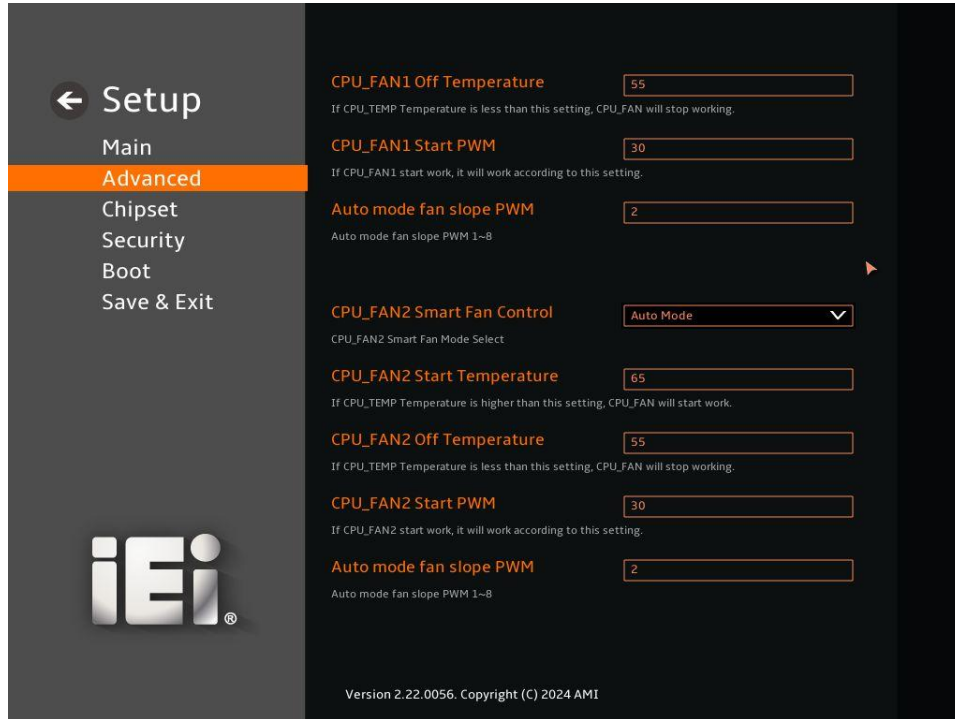

Figure 6-17: Smart Fan Mode Configuration (2/2)

➔ **CPU_FAN1/CPU_FAN2 Smart Fan Control [Auto Mode]**

Use the **CPU_FAN1/CPU_FAN2 Smart Fan Control** option to configure the CPU Smart Fan.

- ➔ **Manual Mode** The fan spins at the speed set in Manual Mode settings.
- ➔ **Auto Mode** **DEFAULT** The fan adjusts its speed using Auto Mode settings.

➔ **CPU_FAN1/CPU_FAN2 start temperature**

If the CPU/System temperature is between fan off and fan start, the fan speed change to fan start PWM. To set a value, Use the + or – key to change the value or enter a decimal number between 1 and 100.

SHIELD-156/185/215

→ CPU_FAN1/CPU_FAN2 off temperature

If the CPU/System temperature is lower than the value set this option, the fan speed change to be lowest. To set a value, Use the + or – key to change the value or enter a decimal number between 1 and 100.

→ CPU_FAN1/CPU_FAN2 start PWM

Use the CPU_FAN1/SYS_FAN1/SYS_FAN2 Start PWM option to set the PWM start value. Use the + or – key to change the value or enter a decimal number between 1 and 100.

→ Auto mode fan slope PWM

Use the Auto mode fan slope PWM option to select the linear rate at which the PWM mode increases with respect to an increase in temperature. Use the + or – key to change the value or enter a decimal number between 1 and 8

6.3.7 Serial Port Console Redirection

The **Serial Port Console Redirection** menu allows the console redirection options to be configured. Console Redirection allows users to maintain a system remotely by re-directing keyboard input and text output through the serial port.

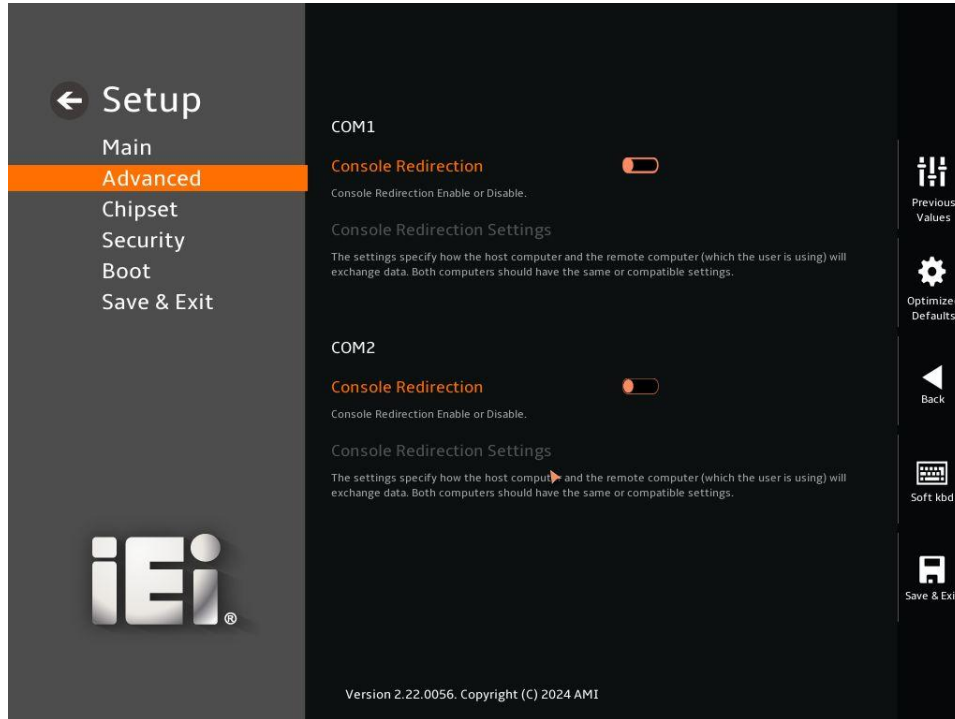

Figure 6-18: Serial Port Console Redirection

➔ **Console Redirection [Disabled]**

Use **Console Redirection** option to enable or disable the console redirection function.

- ➔ **Disabled** **DEFAULT** Disabled the console redirection function
- ➔ **Enabled** Enabled the console redirection function

The **Console Redirection Settings** submenu will be available when the **Console Redirection** option is enabled.

6.3.7.1 Console Redirection Settings

The following options are available in the **Console Redirection Settings** submenu when the COM Console Redirection (for COM1 to COM2) option is enabled.



Figure 6-19: Console Redirection Settings

➔ **Terminal Type [ANSI]**

Use the **Terminal Type** option to specify the remote terminal type.

- ➔ **VT100** The target terminal type is VT100
- ➔ **VT100Plus** The target terminal type is VT100Plus
- ➔ **VT-UTF8** The target terminal type is VT-UTF8
- ➔ **ANSI** **DEFAULT** The target terminal type is ANSI

➔ **Bits per second [115200]**

Use the **Bits per second** option to specify the serial port transmission speed. The speed must match on the other side. Long or noisy lines may require lower speeds.

- ➔ **9600** Sets the serial port transmission speed at 9600.

- **19200** Sets the serial port transmission speed at 19200.
- **38400** Sets the serial port transmission speed at 38400.
- **57600** Sets the serial port transmission speed at 57600.
- **115200** **DEFAULT** Sets the serial port transmission speed at 115200.
- **230400** Sets the serial port transmission speed at 230400.
- **460800** Sets the serial port transmission speed at 460800.
- **921600** Sets the serial port transmission speed at 921600.

→ **Data Bits [8]**

Use the **Data Bits** option to specify the number of data bits.

- **7** Sets the data bits at 7.
- **8** **DEFAULT** Sets the data bits at 8.

→ **Parity [None]**

Use the **Parity** option to specify the parity bit that can be sent with the data bits for detecting the transmission errors.

- **None** **DEFAULT** No parity bit is sent with the data bits.
- **Even** The parity bit is 0 if the number of ones in the data bits is even.
- **Odd** The parity bit is 0 if the number of ones in the data bits is odd.
- **Mark** The parity bit is always 1. This option does not allow for error detection.

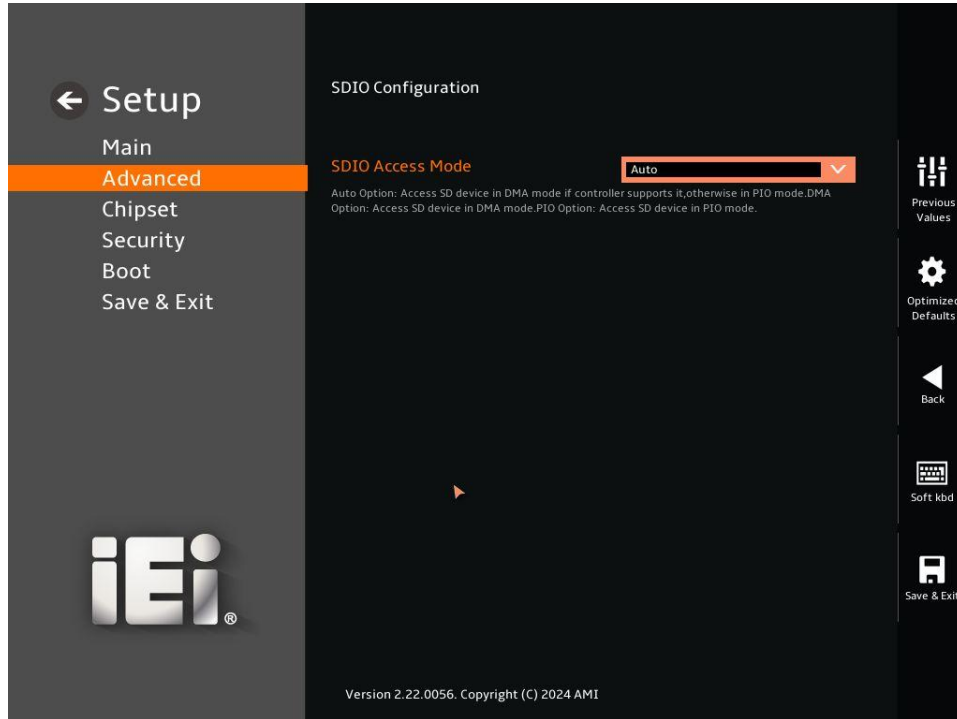

Figure 6-21: SDIO Configuration

➔ **SDIO Access Mode [Auto]**

Use the **SDIO Access Mode** option to specify the access mode for the SD device.

- ➔ **AUTO** **DEFAULT** Access SD device in DMA MODE if controller supports it, otherwise in PIO MODE.
- ➔ **ADMA** Access SD device in ADMA mode.
- ➔ **SDMA** Access SD device in SDMA mode.
- ➔ **PIO** Access SD device in PIO mode.

6.4 Chipset

6.4.1 System Agent (SA) Configuration

Use the **System Agent (SA) Configuration** menu to configure the System Agent (SA) parameters.

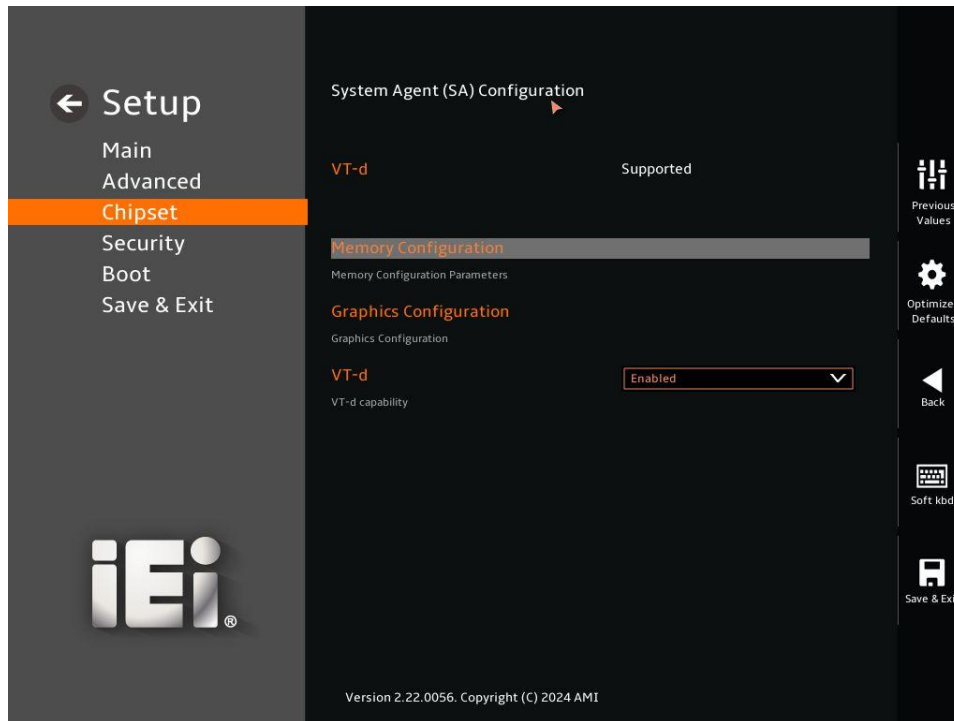

Figure 6-22: System Agent (SA) Configuration

6.4.1.1 Memory Configuration

Use the **Memory Configuration** submenu to view memory information.

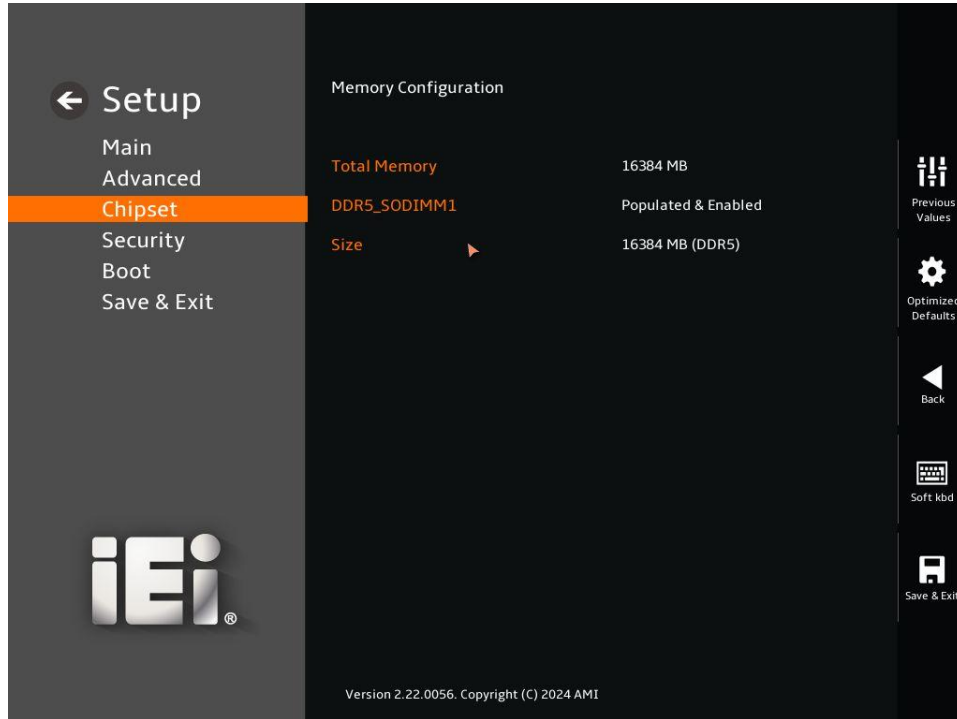

Figure 6-23: Memory Configuration

6.4.1.2 Graphics Configuration

Use the **Graphics Configuration** menu to configure the system's graphics.

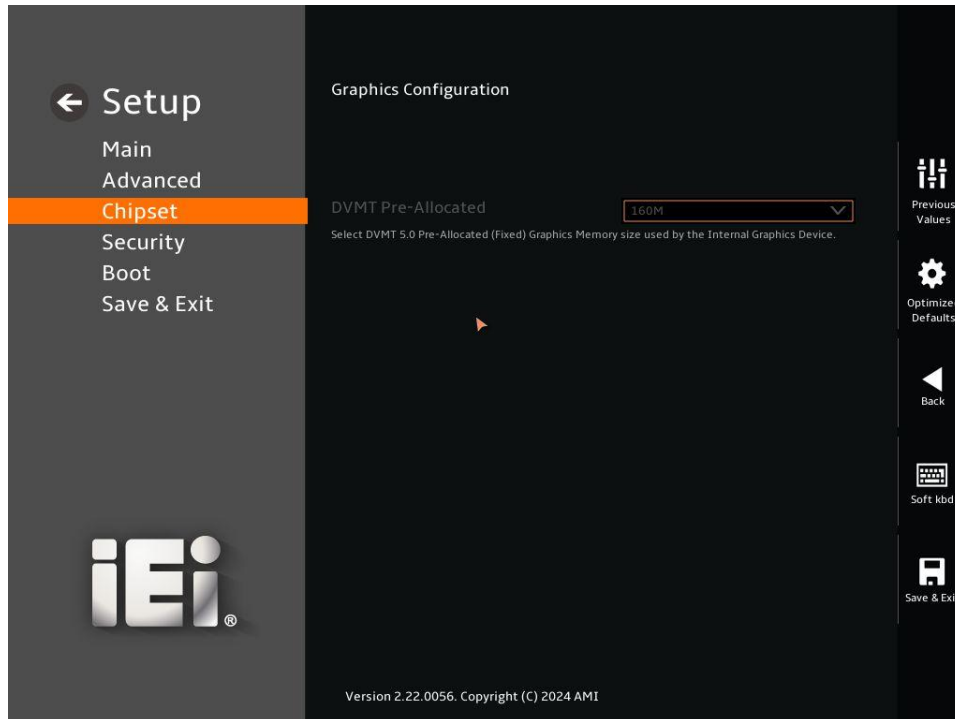

Figure 6-24: Graphics Configuration

→ **DVMT Pre-Allocated [128M]**

Use the **DVMT Pre-Allocated** option to set the amount of system memory allocated to the integrated graphics processor when the system boots. The system memory allocated can then only be used as graphics memory, and is no longer available to applications or the operating system. Configuration options are listed below:

- 128M **Default**
- 0M
- 32M
- 64M
- 96M
- 4M
- 8M
- 12M
- 16M
- 20M
- 24M
- 28M

- 32M/F7
- 36M
- 40M
- 44M
- 48M
- 52M
- 56M
- 60M

6.4.1.3 VT-d

Check to enable VT-d function on MCH. This option will be grayed out when 'X2APIC Enable' option is configured as 'Enabled'.

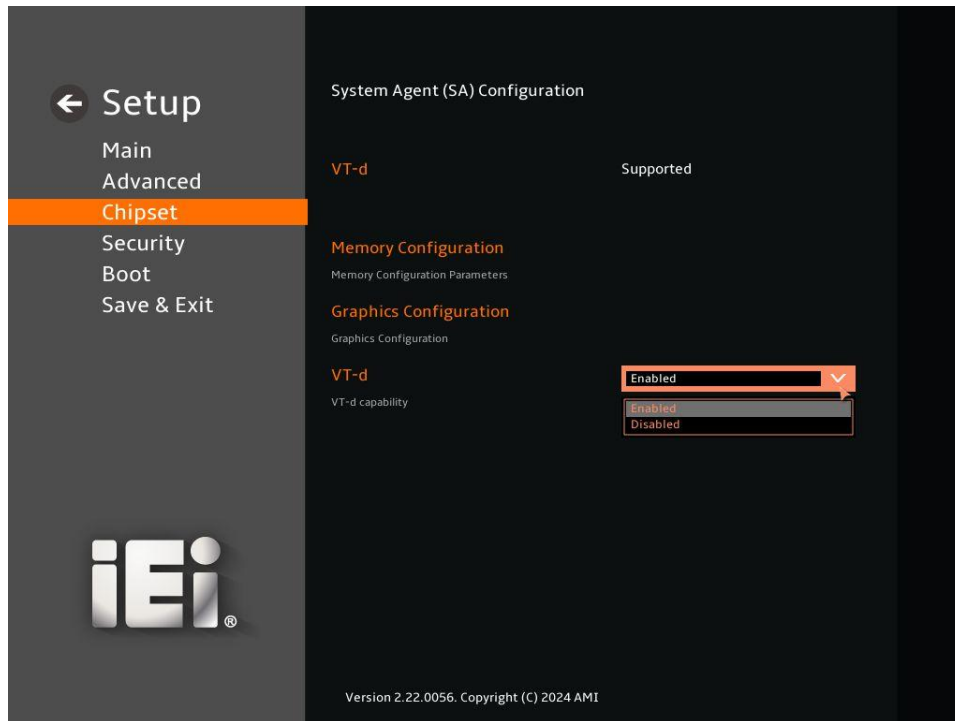

Figure 6-25: VT-d

6.4.2 PCH-IO Configuration

Use the **PCH-IO Configuration** menu to configure the PCH parameters.



Figure 6-26: PCH-IO Configuration (1/2)



Figure 6-27: PCH-IO Configuration (2/2)

➔ **Auto Power Button Function [Disabled (ATX)]**

Use the **Auto Power Button Function** BIOS option to show the power mode state. Use the **J_ATX_AT1** to switch the AT/ATX power mode.

- ➔ **Enabled (AT)** **DEFAULT** The system power mode is AT.
- ➔ **Disabled (ATX)** The system power mode is ATX.

➔ **Restore AC Power Loss [Last State]**

Use the **Restore AC Power Loss** BIOS option to specify what state the system returns to if there is a sudden loss of power to the system when the power mode is ATX.

- ➔ **Power Off** The system remains turned off
- ➔ **Power On** The system turns on
- ➔ **Last State** **DEFAULT** The system returns to its previous state. If it was on, it turns itself on. If it was off, it remains off.

SHIELD-156/185/215**→ Power Saving Function (EUP) [Disabled]**

Use the **Power Saving Function (EUP)** BIOS option to enable or disable the power saving function.

- **Disabled** **DEFAULT** Power saving function is disabled.
- **Enabled** Power saving function is enabled. It will reduce power consumption when the system is off.

→ USB Power SW1 (USB30_M12) [+5V DUAL]

Use the **USB Power SW1** BIOS option to configure the USB power source for the corresponding USB connectors.

+5V DUAL: Keep USB power present under S0/S3/S4/SS.

+5V: Keep USB power present under so only (S3/S4/SS off).

- **+5V DUAL** **DEFAULT** Sets the USB power source to +5V dual
- **+5V** Sets the USB power source to +5V

→ USB Power SW2 (USB20_M12) [+5V DUAL]

Use the **USB Power SW2** BIOS option to configure the USB power source for the corresponding USB connectors.

+5V DUAL: Keep USB power present under S0/S3/S4/SS.

+5V: Keep USB power present under so only (S3/S4/SS off).

- **+5V DUAL** **DEFAULT** Sets the USB power source to +5V dual
- **+5V** Sets the USB power source to +5V

→ USB Power SW3 (TH_USB1/CAM_USB1/USB1) [+5V DUAL]

Use the **USB Power SW3** BIOS option to configure the USB power source for the corresponding USB connectors.

+5V DUAL: Keep USB power present under S0/S3/S4/SS.

+5V: Keep USB power present under so only (S3/S4/SS off).

- **+5V DUAL** **DEFAULT** Sets the USB power source to +5V dual

➔ **+5V**

Sets the USB power source to +5V

6.4.2.1 PCI Express Configuration

Use the PCI Express Configuration menu to configure the M2_B1 slot, M2_A1 slot, M2_M2 slot, M2_M1 slot and NVME.



Figure 6-28 PCI Express Configuration

6.4.2.2 M2_B1

Use the **M2_B1** menu to change and/or set the configuration of the M2_B1 devices installed in the system.

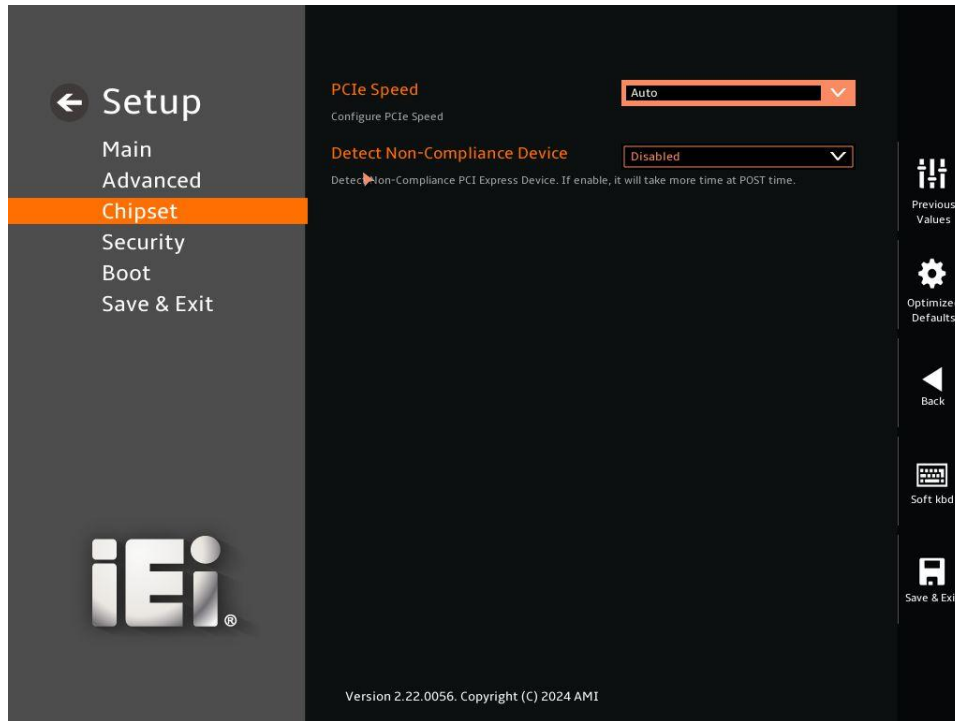

Figure 6-29: M2_B1

→ PCIe Speed [Auto]

Use the **PCIe Speed** option to specify the PCI Express port speed. Configuration options are listed below.

- | | | | |
|---|-------------|----------------|-------------------------------|
| → | Auto | DEFAULT | Auto mode. |
| → | Gen1 | | Configure PCIe Speed to Gen1. |
| → | Gen2 | | Configure PCIe Speed to Gen2. |
| → | Gen3 | | Configure PCIe Speed to Gen3. |

→ Detect Non-Compliance Device [Disabled]

Use the **Detect Non-Compliance Device** to detect Non-Compliance PCI Express Device. If enabled, it will take more time at POST time.

- | | | | |
|---|-----------------|----------------|---|
| → | Disabled | | Disable the Detect Non-Compliance Device. |
| → | Enabled | DEFAULT | Enable the Detect Non-Compliance Device. |

6.4.2.3 M2_A1

Use the **M2_A1** menu to change and/or set the configuration of the M2_A1 devices installed in the system.

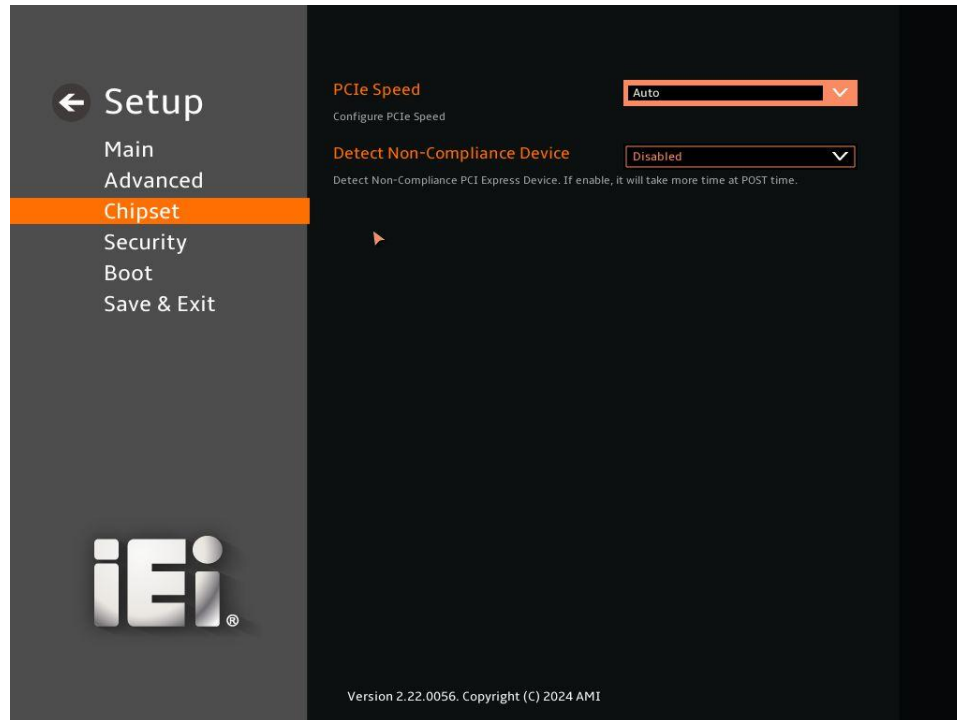

Figure 6-30: M2_A1

➔ **PCIe Speed [Auto]**

Use the **PCIe Speed** option to specify the PCI Express port speed. Configuration options are listed below.

- ➔ **Auto** **DEFAULT** Auto mode.
- ➔ **Gen1** Configure PCIe Speed to Gen1.
- ➔ **Gen2** Configure PCIe Speed to Gen2.
- ➔ **Gen3** Configure PCIe Speed to Gen3.

➔ **Detect Non-Compliance Device [Disabled]**

Use the **Detect Non-Compliance Device** to detect Non-Compliance PCI Express Device. If enabled, it will take more time at POST time.

SHIELD-156/185/215

- ➔ **Disabled** Disable the Detect Non-Compliance Device.
- ➔ **Enabled** **DEFAULT** Enable the Detect Non-Compliance Device.

6.4.2.4 M2_M2

Use the **M2_M2** menu to change and/or set the configuration of the M2_M2 devices installed in the system.

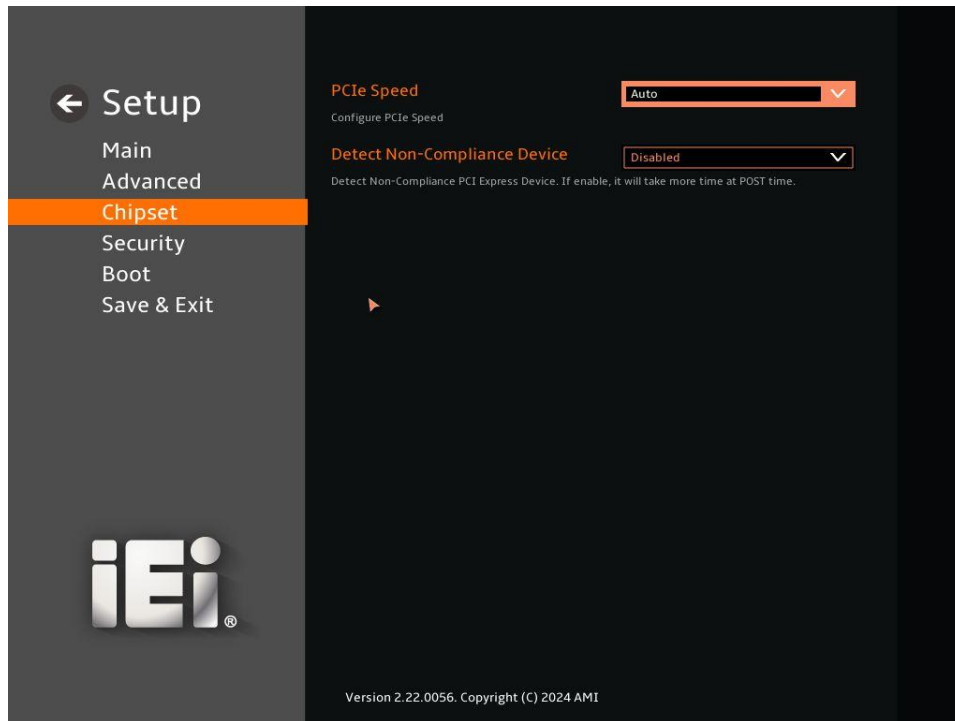

Figure 6-31: M2_M2

➔ **PCIe Speed [Auto]**

Use the **PCIe Speed** option to specify the PCI Express port speed. Configuration options are listed below.

- ➔ **Auto** **DEFAULT** Auto mode.
- ➔ **Gen1** Configure PCIe Speed to Gen1.
- ➔ **Gen2** Configure PCIe Speed to Gen2.
- ➔ **Gen3** Configure PCIe Speed to Gen3.

SHIELD-156/185/215

- ➔ **Gen2** Configure PCIe Speed to Gen2.
- ➔ **Gen3** Configure PCIe Speed to Gen3.

➔ **Detect Non-Compliance Device [Disabled]**

Use the **Detect Non-Compliance Device** to detect Non-Compliance PCI Express Device. If enabled, it will take more time at POST time.

- ➔ **Disabled** Disable the Detect Non-Compliance Device.
- ➔ **Enabled** **DEFAULT** Enable the Detect Non-Compliance Device.

6.4.2.6 SATA Configuration

Use the **SATA Configuration** menu to change and/or set the configuration of the SATA devices installed in the system.

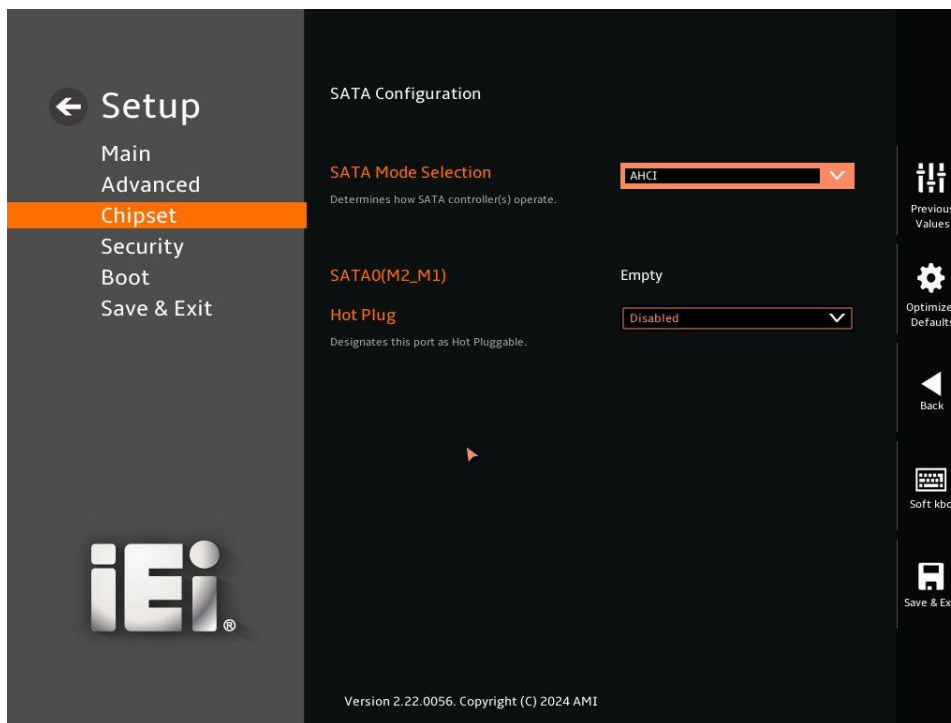

Figure 6-33: SATA Configuration

➔ **SATA Mode Selection [AHCI]**

Use the **SATA Mode Selection** option to determine how the SATA devices operate.

SHIELD-156/185/215

- ➔ **Disabled** The onboard High-Definition Audio controller is disabled.
- ➔ **Enabled** **DEFAULT** The onboard High-Definition Audio controller is enabled.

6.4.2.8 SCS Configuration

Use the **SCS Configuration** menu to change and/or set the configuration of the SCS (Storage Control System) devices installed in the system.

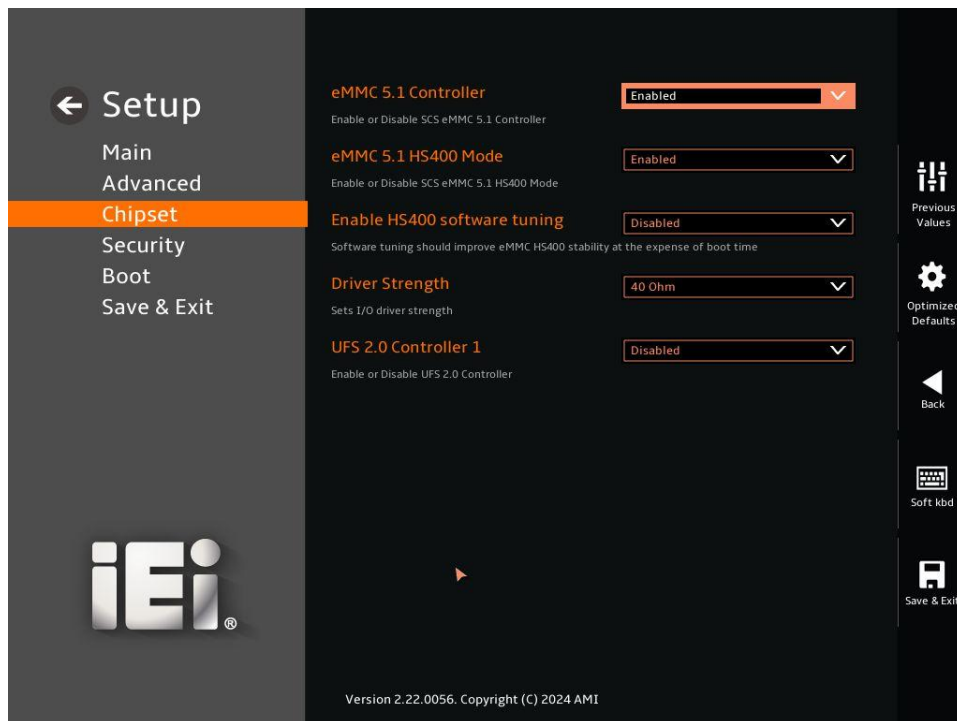

Figure 6-35: SCS Configuration

➔ eMMC 5.1 Controller [Enabled]

Use the **eMMC 5.1 Controller** option to enable or disable SCS eMMC 5.1 Controller.

- ➔ **Disabled** The SCS eMMC 5.1 Controller is disabled.
- ➔ **Enabled** **DEFAULT** The SCS eMMC 5.1 Controller is enabled.

➔ eMMC 5.1 HS400 Mode [Enabled]

Use the **eMMC 5.1 HS400 Mode** option to enable or disable SCS eMMC 5.1 HS400 Mode.

- **Disabled** The SCS eMMC 5.1 HS400 Mode is disabled.
- **Enabled** **DEFAULT** The SCS eMMC 5.1 HS400 Mode is enabled.

→ **Enable HS400 software tuning [Enabled]**

Use the **Enable HS400 software tuning** option to configure software tuning. Software tuning should improve eMMC HS400 stability at the expense of boot time.

- **Disabled** **DEFAULT** Disabled the HS400 software tuning.
- **Enabled** Enable the HS400 software tuning.

→ **Driver Strength [40 Ohm]**

Use the **Driver Strength** option to set I/O driver strength.

- **33Ohm** Set I/O driver strength to 33 Ohm.
- **40Ohm** **DEFAULT** Set I/O driver strength to 40 Ohm.
- **50Ohm** Set I/O driver strength to 50 Ohm.

→ **UFS 2.0 Controller 1 [Disabled]**

Use the **UFS 2.0 Controller 1** option to enable or disable UFS 2.0 Controller.

- **Disabled** **DEFAULT** Disabled the UFS 2.0 Controller 1.
- **Enabled** Enable the UFS 2.0 Controller 1.

6.5 Security

Use the **Security** menu to set system and user passwords.

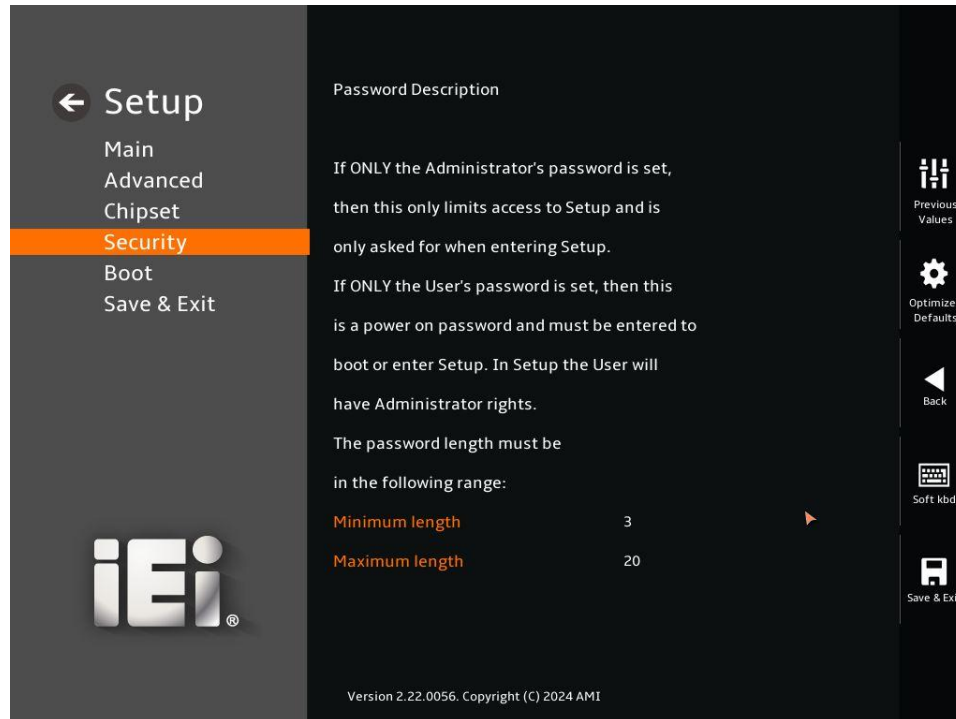

Figure 6-36: Security (1/2)



Figure 6-37: Security (2/2)

➔ **Administrator Password**

Use the **Administrator Password** to set or change an administrator password.

➔ **User Password**

Use the **User Password** to set or change a user password.

6.6 Boot

Use the **Boot** menu to configure system boot options.

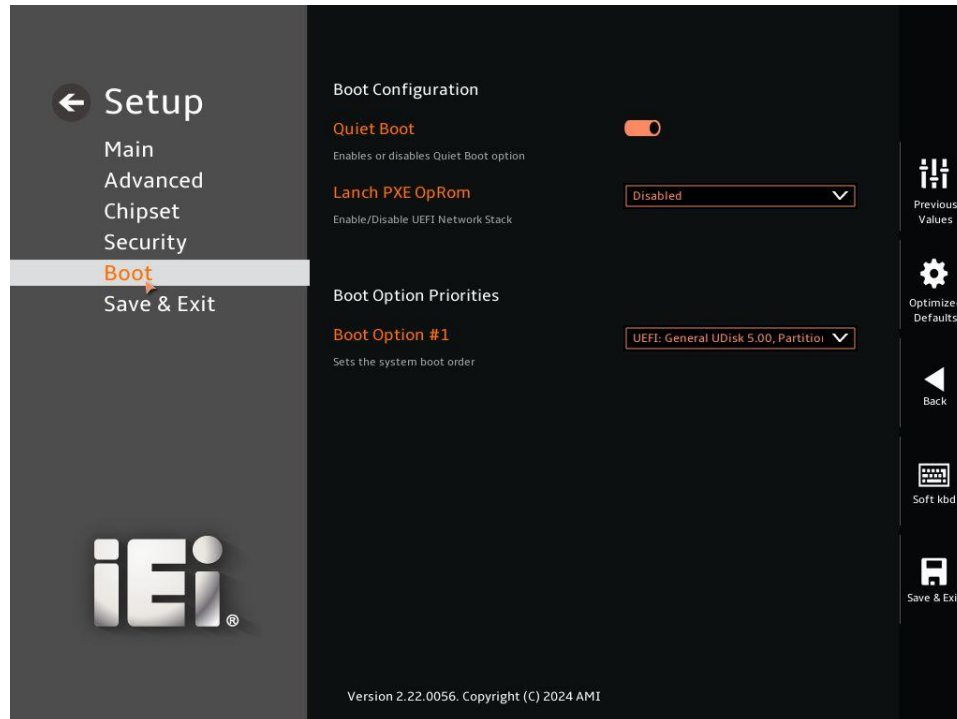

Figure 6-38: Boot

6.6.1 Boot Configuration

→ Quiet Boot [Enabled]

Use the **Quiet Boot** BIOS option to select the screen display when the system boots.

- **Disabled** Normal POST messages displayed
- **Enabled** **DEFAULT** OEM Logo displayed instead of POST messages

→ Launch PXE OpRom [Disabled]

Use the **Launch PXE OpRom** option to enable or disable boot option for legacy network devices.

- **Disabled** **DEFAULT** Ignore all PXE Option ROMs

→ Enabled

Load PXE Option ROMs.

6.7 Save & Exit

Use the **Save & Exit** menu to load default BIOS values, optimal failsafe values and to save configuration changes.

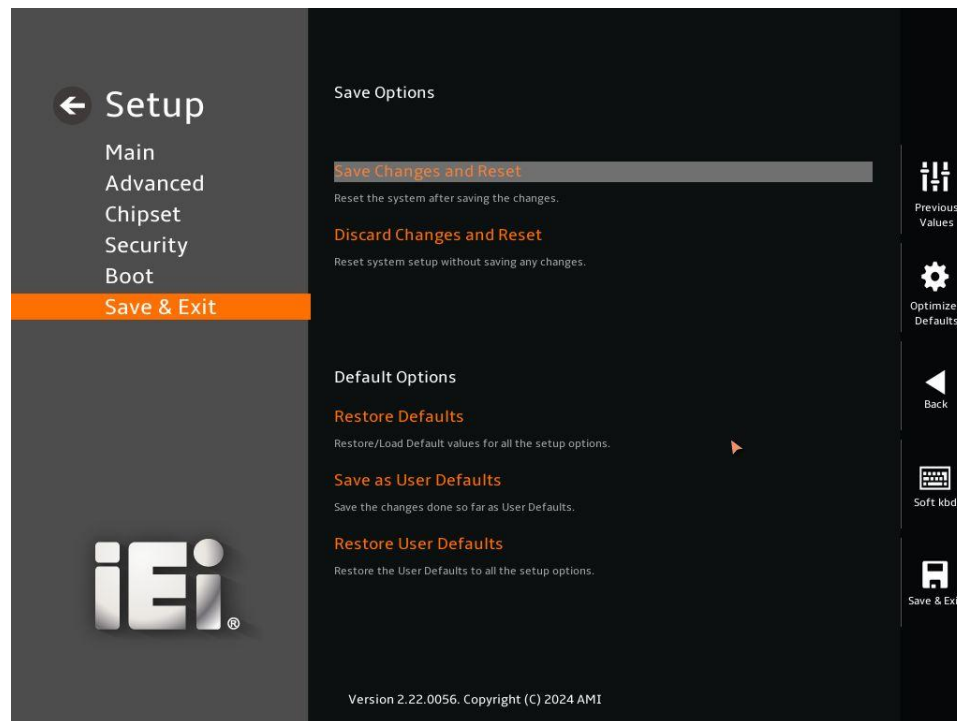

Figure 6-39: Save & Exit

→ Save Changes and Reset

Use the **Save Changes and Reset** option to save the changes made to the BIOS options and reset the system.

→ Discard Changes and Reset

Use the **Discard Changes and Reset** option to exit the system without saving the changes made to the BIOS configuration setup program.

→ Restore Defaults

Use the **Restore Defaults** option to load the optimal default values for each of the parameters on the Setup menus. **F3 key can be used for this operation.**

SHIELD-156/185/215

→ Save as User Defaults

Use the **Save as User Defaults** option to save the changes done so far as user defaults.

→ Restore User Defaults

Use the **Restore User Defaults** option to restore the user defaults to all the setup options.

Appendix

A

Regulatory Compliance

DECLARATION OF CONFORMITY



This equipment is in conformity with the following EU directives:

- EMC Directive (2014/30/EU)
- Low-Voltage Directive (2014/35/EU)
- RoHS II Directive (2015/863/EU)

If the user modifies and install other devices in the equipment, the CE conformity declaration may no longer apply.

If this equipment has telecommunications functionality, it also complies with the requirements of the Radio Equipment Directive 2014/53/EU.

Hereby, IEI INTEGRATION CORP declares that the radio equipment types SHIELD-156、SHIELD-185、SHIELD-215 are in compliance with Directive 2014/53/EU. The full text of the EU declaration of conformity is available at the following internet address: <https://www.ieiworld.com>

	AT	BE	BG	CH	CY	CZ	DE	DK	EE	EL	ES
	FI	FR	HR	HU	IE	IS	IT	LI	LT	LU	LV
	MT	NL	NO	PL	PT	RO	SE	SI	SK	TR	UK (NI)

English

IEI Integration Corp declares that this equipment is in compliance with the essential requirements and other relevant provisions of Directive 2014/53/EU.

Български [Bulgarian]

IEI Integration Corp. декларира, че този оборудване е в съответствие със съществените изисквания и другите приложими правила на Директива 2014/53/EU.

Česky [Czech]

IEI Integration Corp tímto prohlašuje, že tento zařizení je ve shodě se základními požadavky a dalšími příslušnými ustanoveními směrnice 2014/53/EU.

Dansk [Danish]

IEI Integration Corp erklærer herved, at følgende udstyr overholder de væsentlige krav og øvrige relevante krav i direktiv 2014/53/EU.

Deutsch [German]

IEI Integration Corp, erklärt dieses Gerät entspricht den grundlegenden Anforderungen und den weiteren entsprechenden Vorgaben der Richtlinie 2014/53/EU.

Eesti [Estonian]

IEI Integration Corp deklareerib seadme seadme vastavust direktiivi 2014/53/EÜ põhinõuetele ja nimetatud direktiivist tulenevatele teistele asjakohastele sätetele.

Español [Spanish]

IEI Integration Corp declara que el equipo cumple con los requisitos esenciales y cualesquiera otras disposiciones aplicables o exigibles de la Directiva 2014/53/EU.

Ελληνική [Greek]

IEI Integration Corp ΔΗΛΩΝΕΙ ΟΤΙ ΕΞΟΠΛΙΣΜΟΣ ΣΥΜΜΟΡΦΩΝΕΤΑΙ ΠΡΟΣ ΤΙΣ ΟΥΣΙΩΔΕΙΣ ΑΠΑΙΤΗΣΕΙΣ ΚΑΙ ΤΙΣ ΛΟΙΠΕΣ ΣΧΕΤΙΚΕΣ ΔΙΑΤΑΞΕΙΣ ΤΗΣ ΟΔΗΓΙΑΣ 2014/53/EU.

Français [French]

IEI Integration Corp déclare que l'appareil est conforme aux exigences essentielles et aux autres dispositions pertinentes de la directive 2014/53/EU.

Italiano [Italian]

IEI Integration Corp dichiara che questo apparecchio è conforme ai requisiti essenziali ed alle altre disposizioni pertinenti stabilite dalla direttiva 2014/53/EU.

Latviski [Latvian]

IEI Integration Corp deklarē, ka iekārta atbilst būtiskajām prasībām un citiem ar to saistītajiem noteikumiem Direktīvas 2014/53/EU.

Lietuvių [Lithuanian]

IEI Integration Corp deklaruoja, kad šis įranga atitinka esminius reikalavimus ir kitas 2014/53/EU Direktyvos nuostatas.

Nederlands [Dutch]

IEI Integration Corp dat het toestel in overeenstemming is met de essentiële eisen en de andere relevante bepalingen van richtlijn 2014/53/EU.

SHIELD-156/185/215

Malti [Maltese]

IEI Integration Corp jiddikjara li dan prodott jikkonforma mal-ħtiġijiet essenzjali u ma provvedimenti oħrajn rilevanti li hemm fid-Dirrettiva 2014/53/EU.

Magyar [Hungarian]

IEI Integration Corp nyilatkozom, hogy a berendezés megfelel a vonatkozó alapvető követelményeknek és az 2014/53/EU irányelv egyéb előírásainak.

Polski [Polish]

IEI Integration Corp oświadcza, że wyrobu jest zgodny z zasadniczymi wymogami oraz pozostałymi stosownymi postanowieniami Dyrektywy 2014/53/EU.

Português [Portuguese]

IEI Integration Corp declara que este equipamento está conforme com os requisitos essenciais e outras disposições da Directiva 2014/53/EU.

Româna [Romanian]

IEI Integration Corp declară că acest echipament este în conformitate cu cerințele esențiale și cu celelalte prevederi relevante ale Directivei 2014/53/EU.

Slovensko [Slovenian]

IEI Integration Corp izjavlja, da je ta opreme v skladu z bistvenimi zahtevami in ostalimi relevantnimi določili direktive 2014/53/EU.

Slovensky [Slovak]

IEI Integration Corp týmto vyhlasuje, že zariadenia spĺňa základné požiadavky a všetky príslušné ustanovenia Smernice 2014/53/EU.

Suomi [Finnish]

IEI Integration Corp vakuuttaa täten että laitteet on direktiivin 2014/53/EU oleellisten vaatimusten ja sitä koskevien direktiivin muiden ehtojen mukainen.

Svenska [Swedish]

IEI Integration Corp förklarar att denna utrustningstyp står i överensstämmelse med de väsentliga egenskapskrav och övriga relevanta bestämmelser som framgår av direktiv 2014/53/EU.

FCC WARNING

This equipment complies with Part 15 of the FCC Rules. Operation is subject to the following two conditions:

- This device may not cause harmful interference, and
- This device must accept any interference received, including interference that may cause undesired operation.

This equipment has been tested and found to comply with the limits for a Class A digital device, pursuant to part 15 of the FCC Rules. These limits are designed to provide reasonable protection against harmful interference when the equipment is operated in a commercial environment. This equipment generates, uses, and can radiate radio frequency energy and, if not installed and used in accordance with the instruction manual, may cause harmful interference to radio communications. Operation of this equipment in a residential area is likely to cause harmful interference in which case the user will be required to correct the interference at his own expense.

Any changes or modifications not expressly approved by the party responsible for compliance could void the user's authority to operate the equipment.

This equipment complies with FCC radiation exposure limits set forth for an uncontrolled environment. This equipment should be installed and operated with a minimum distance of 20cm between the radiator & your body.

Appendix

B

Safety Precautions

**WARNING:**

The precautions outlined in this chapter should be strictly followed. Failure to follow these precautions may result in permanent damage to the SHIELD-156/185/215.

B.1 Safety Precautions

Please follow the safety precautions outlined in the sections that follow:

B.1.1 General Safety Precautions

Please ensure the following safety precautions are adhered to at all times.

- **Follow the electrostatic precautions** outlined below whenever the device is opened.
- **Make sure the power is turned off and the power cord is disconnected** whenever the SHIELD-156/185/215 is being installed, moved or modified.
- **To prevent the risk of electric shock, make sure power cord is unplugged from wall socket.** To fully disengage the power to the unit, please disconnect the power cord from the AC outlet. Refer servicing to qualified service personnel. The AC outlet shall be readily available and accessible.
- **Do not apply voltage levels that exceed the specified voltage range.** Doing so may cause fire and/or an electrical shock. Use a power cord that matches the voltage of the power outlet, which has been approved and complies with the safety standard of your particular country.
- **Electric shocks can occur** if the SHIELD-156/185/215 chassis is opened when it is running. To avoid risk of electric shock, this device must only be connected to a supply main with protective earth.
- **Do not drop or insert any objects** into the ventilation openings of the SHIELD-156/185/215.

SHIELD-156/185/215

- ***If considerable amounts of dust, water, or fluids enter the device,*** turn off the power supply immediately, unplug the power cord, and contact the SHIELD-156/185/215 vendor.
- ***RTC battery safety precautions:***
 - RISK OF EXPLOSION IF BATTERY IS REPLACED BY AN INCORRECT TYPE
 - Disposal of a battery into fire or a hot oven, or mechanically crushing or cutting of a battery, that can result in an explosion
 - Leaving a battery in an extremely high temperature surrounding environment that can result in an explosion or the leakage of flammable liquid or gas
 - A battery subjected to extremely low air pressure that may result in an explosion or the leakage of flammable liquid or gas
- ***DO NOT:***
 - Drop the device against a hard surface.
 - Strike or exert excessive force onto the LCD panel.
 - Touch any of the LCD panels with a sharp object
 - In a site where the ambient temperature exceeds the rated temperature

B.1.2 Anti-static Precautions



WARNING:

Failure to take ESD precautions during the installation of the SHIELD-156/185/215 may result in permanent damage to the SHIELD-156/185/215 and severe injury to the user.

Electrostatic discharge (ESD) can cause serious damage to electronic components, including the SHIELD-156/185/215. Dry climates are especially susceptible to ESD. It is therefore critical that whenever the SHIELD-156/185/215 is opened and any of the electrical components are handled, the following anti-static precautions are strictly adhered to.

- **Wear an anti-static wristband:** Wearing a simple anti-static wristband can help to prevent ESD from damaging any electrical component.
- **Self-grounding:** Before handling any electrical component, touch any grounded conducting material. During the time the electrical component is handled, frequently touch any conducting materials that are connected to the ground.
- **Use an anti-static pad:** When configuring or working with an electrical component, place it on an anti-static pad. This reduces the possibility of ESD damage.
- **Only handle the edges of the electrical component:** When handling the electrical component, hold the electrical component by its edges.

B.1.3 Product Disposal



CAUTION:

Risk of explosion if battery is replaced by an incorrect type. Only certified engineers should replace the on-board battery.

Dispose of used batteries according to instructions and local regulations.

- Outside the European Union–If you wish to dispose of used electrical and electronic products outside the European Union, please contact your local authority so as to comply with the correct disposal method.
- Within the European Union–The device that produces less waste and is easier to recycle is classified as electronic device in terms of the European Directive 2012/19/EU (WEEE), and must not be disposed of as domestic garbage.

SHIELD-156/185/215



EU-wide legislation, as implemented in each Member State, requires that waste electrical and electronic products carrying the mark (left) must be disposed of separately from normal household waste. This includes monitors and electrical accessories, such as signal cables or power cords. When you need to dispose of your display products, please follow the guidance of your local authority, or ask the shop where you purchased the product. The mark on electrical and electronic products only applies to the current European Union Member States.

Please follow the national guidelines for electrical and electronic product disposal.

B.2 Maintenance and Cleaning Precautions

When maintaining or cleaning the SHIELD-156/185/215, please follow the guidelines below.



WARNING:

- For safety reasons, turn-off the power and unplug the panel PC before cleaning.
- If you dropped any material or liquid such as water onto the panel PC when cleaning, unplug the power cable immediately and contact your dealer or the nearest service center. Always make sure your hands are dry when unplugging the power cable.

B.2.1 Maintenance and Cleaning

Prior to cleaning any part or component of the SHIELD-156/185/215, please read the details below.

- Except for the LCD panel, never spray or squirt liquids directly onto any other components. To clean the LCD panel, gently wipe it with a piece of soft dry cloth or a slightly moistened cloth.
- The interior of the device does not require cleaning. Keep fluids away from the device interior.

- Be cautious of all small removable components when vacuuming the device.
- Never drop any objects or liquids through the openings of the device.
- Be cautious of any possible allergic reactions to solvents or chemicals used when cleaning the device.
- Avoid eating, drinking and smoking within vicinity of the device.

B.2.2 Cleaning Tools

Some components in the SHIELD-156/185/215 may only be cleaned using a product specifically designed for the purpose. In such case, the product will be explicitly mentioned in the cleaning tips. Below is a list of items to use when cleaning the SHIELD-156/185/215.

- **Cloth**—Although paper towels or tissues can be used, a soft, clean piece of cloth is recommended when cleaning the device.
- **Water or rubbing alcohol**—A cloth moistened with water or rubbing alcohol can be used to clean the device.
- **Using solvents**—The use of solvents is not recommended when cleaning the device as they may damage the plastic parts.
- **Vacuum cleaner**—Using a vacuum specifically designed for computers is one of the best methods of cleaning the device. Dust and dirt can restrict the airflow in the device and cause its circuitry to corrode.
- **Cotton swabs**—Cotton swabs moistened with rubbing alcohol or water are excellent tools for wiping hard to reach areas.
- **Foam swabs**—Whenever possible, it is best to use lint free swabs such as foam swabs for cleaning.

Appendix

C

Watchdog Timer



NOTE:

The following discussion applies to DOS. Contact IEI support or visit the IEI website for drivers for other operating systems.

The Watchdog Timer is a hardware-based timer that attempts to restart the system when it stops working. The system may stop working because of external EMI or software bugs. The Watchdog Timer ensures that standalone systems like ATMs will automatically attempt to restart in the case of system problems.

A BIOS function call (INT 15H) is used to control the Watchdog Timer.

INT 15H:

AH – 6FH Sub-function:	
AL – 2:	Sets the Watchdog Timer's period.
BL:	Time-out value (Its unit-second is dependent on the item "Watchdog Timer unit select" in CMOS setup).

Table C-1: AH-6FH Sub-function

Call sub-function 2 to set the time-out period of Watchdog Timer first. If the time-out value is not zero, the Watchdog Timer starts counting down. When the timer value reaches zero, the system resets. To ensure that this reset condition does not occur, calling sub-function 2 must periodically refresh the Watchdog Timer. However, the watchdog timer is disabled if the time-out value is set to zero.

A tolerance of at least 10% must be maintained to avoid unknown routines within the operating system (DOS), such as disk I/O that can be very time-consuming.

SHIELD-156/185/215

**NOTE:**

The Watchdog Timer is activated through software. The software application that activates the Watchdog Timer must also deactivate it when closed. If the Watchdog Timer is not deactivated, the system will automatically restart after the Timer has finished its countdown.

EXAMPLE PROGRAM:

; INITIAL TIMER PERIOD COUNTER

;

W_LOOP:

;

```

MOV      AX, 6F02H      ;setting the time-out value
MOV      BL, 30         ;time-out value is 48 seconds
INT      15H

```

;

; ADD THE APPLICATION PROGRAM HERE

;

```

CMP      EXIT_AP, 1     ; is the application over?
JNE      W_LOOP        ; No, restart the application

MOV      AX, 6F02H     ; disable Watchdog Timer
MOV      BL, 0         ;
INT      15H

```

;

; EXIT;

Appendix

D

Hazardous Materials Disclosure

SHIELD-156/185/215

D.1.1 RoHS II Directive (2015/863/EU)

The details provided in this appendix are to ensure that the product is compliant with the RoHS II Directive (2015/863/EU). The table below acknowledges the presences of small quantities of certain substances in the product, and is applicable to RoHS II Directive (2015/863/EU).

Please refer to the following table.

Part Name	Toxic or Hazardous Substances and Elements									
	Lead (Pb)	Mercury (Hg)	Cadmium (Cd)	Hexavalent Chromium (CR(VI))	Polybrominated Biphenyls (PBB)	Polybrominated Diphenyl Ethers (PBDE)	Bis(2-ethylhexyl) phthalate (DEHP)	Butyl benzyl phthalate (BBP)	Dibutyl phthalate (DBP)	Diisobutyl phthalate (DIBP)
Housing	O	O	O	O	O	O	O	O	O	O
Printed Circuit Board	O	O	O	O	O	O	O	O	O	O
Metal Fasteners	O	O	O	O	O	O	O	O	O	O
Cable Assembly	O	O	O	O	O	O	O	O	O	O
Fan Assembly	O	O	O	O	O	O	O	O	O	O
Power Supply Assemblies	O	O	O	O	O	O	O	O	O	O
Battery	O	O	O	O	O	O	O	O	O	O
<p>O: This toxic or hazardous substance is contained in all of the homogeneous materials for the part is below the limit requirement in Directive (EU) 2015/863.</p> <p>X: This toxic or hazardous substance is contained in at least one of the homogeneous materials for this part is above the limit requirement in Directive (EU) 2015/863.</p>										

D.1.2 China RoHS

此附件旨在确保本产品符合中国 RoHS 标准。以下表格标示此产品中某有毒物质的含量符合中国 RoHS 标准规定的限量要求。

本产品上会附有“环境友好使用期限”的标签，此期限是估算这些物质“不会有泄漏或突变”的年限。本产品可能包含有较短的环境友好使用期限的可替换元件，像是电池或灯管，这些元件将会单独标示出来。

部件名称	有毒有害物质或元素					
	铅 (Pb)	汞 (Hg)	镉 (Cd)	六价铬 (CR(VI))	多溴联苯 (PBB)	多溴二苯醚 (PBDE)
壳体	○	○	○	○	○	○
印刷电路板	○	○	○	○	○	○
金属螺帽	○	○	○	○	○	○
电缆组装	○	○	○	○	○	○
风扇组装	○	○	○	○	○	○
电力供应组装	○	○	○	○	○	○
电池	○	○	○	○	○	○

O: 表示该有毒有害物质在该部件所有物质材料中的含量均在 SJ/T11364-2014 與 GB/T26572-2011 标准规定的限量要求以下。

X: 表示该有毒有害物质至少在该部件的某一均质材料中的含量超出 SJ/T11364-2014 與 GB/T26572-2011 标准规定的限量要求。